

PagePro™ 9100 Series



Service Manual

MINOLTA
QMS

1750053-001B

The essentials of imaging

www.minolta-qms.com

Trademarks

The following are registered trademarks of MINOLTA-QMS, Inc.: QMS and the MINOLTA-QMS logo. Minolta, and PagePro are trademarks of Minolta Co., Ltd. Other product names mentioned in this guide may also be trademarks or registered trademarks of their respective owners.

Proprietary Statement

The digitally encoded software included with your printer is Copyrighted © 2002 by MINOLTA-QMS, Inc. All Rights Reserved. This software may not be reproduced, modified, displayed, transferred, or copied in any form or in any manner or on any media, in whole or in part, without the express written permission of MINOLTA-QMS, Inc.

Copyright Notice

This manual is Copyrighted © 2002 by MINOLTA-QMS, Inc., One Magnum Pass, Mobile, AL 36618. All Rights Reserved. This document may not be copied, in whole or part, nor transferred to any other media or language, without written permission of MINOLTA-QMS, Inc.

Manual Notice

MINOLTA-QMS, Inc. reserves the right to make changes to this manual and to the equipment described herein without notice. Considerable effort has been made to ensure that this manual is free of inaccuracies and omissions. However, MINOLTA-QMS, Inc. makes no warranty of any kind including, but not limited to, any implied warranties of merchantability and fitness for a particular purpose with regard to this manual. MINOLTA-QMS, Inc. assumes no responsibility for, or liability for, errors contained in this manual or for incidental, special, or consequential damages arising out of the furnishing of this manual, or the use of this manual in operating the equipment, or in connection with the performance of the equipment when so operated.

CONTENTS

1.	Safety Precautions for Inspection and Service	1
1-1.	Outlines of safety precautions	1
1-2.	Warning	1
1-3.	Caution	4
1-4.	Other precautions	6
1-5.	Precautions for service	8
1-6.	Safety information	11
	(1) Laser Safety	11
	(2) Internal Laser Radiation	11
1-7.	Laser safety label	14
1-8.	Laser caution label	14
1-9.	Precautions for handling the equipment	14
2.	INSTALLATION	15
2-1.	Installation environment	15
2-2.	Usage environment	16
2-3.	Installing the power supply	16
2-4.	Space requirements	17
	(1) Standard	17
	(2) With options installed	17
3.	GENERAL INFORMATION	19
3-1.	Specifications	19
	(1) Printer	19
	(2) 500-sheet lower feed unit (optional)	22
	(3) Duplex unit (optional)	23
	(4) 4-bin mailbox (optional)	23
3-2.	Parts identification	24
3-3.	Component diagram	26
3-4.	Drive system	27
	(1) Overview of the drive system for the standard configuration	27
	(2) Diagram of the drive system for the standard configuration	28
	(3) Overview of the drive system when options are installed	29
3-5.	Electrical components layout	30
	(1) Printer	30
	(2) Lower feed unit (optional)	32
	(3) Duplex unit (optional)	32
	(4) 4-bin mailbox (optional)	33
3-6.	Electrical components functions	34
	(1) Printer	34
	(2) Lower feed unit (optional)	35
	(3) Duplex unit (optional)	36
	(4) 4-bin mailbox (optional)	36

(5) PWB-A (main control board)	37	
(6) PWB-D (new-imaging-cartridge detection board)	38	
(7) PU1 (power supply board)	38	
(8) HV1 (high voltage unit)	39	
(9) PWB-G (toner-empty detection board)	40	
(10) PWB-H (paper full detection board)	40	
(11) PWB-O (control panel board)	40	
(12) PWB-A (control board of the lower feed unit)	41	
(13) PWB-A (DUP) (control board of the duplex unit)	41	
(14) PWB-A (control board of the 4-bin mailbox)	42	
3-7. Video interface	43	
(1) Overview	43	
(2) Signal descriptions	44	
3-8. Timing chart	45	
(1) Pre-process sequence	45	
(2) Print (print interval) sequence	46	
(3) Post-process sequence	46	
4. MECHANICAL/ELECTRICAL	47	
4-1. Paper path	47	
(1) Standard configuration	47	
(2) With options installed	49	
4-2. Paper take-up section	50	
(1) Multipurpose paper tray: paper take-up mechanisms & process	50	
(2) Multipurpose paper tray: paper feed retry control	52	
(3) Multipurpose paper tray: paper empty detection mechanism	53	
(4) Multipurpose paper tray: paper near-empty detection mechanism	54	
(5) Universalpapercassette(firstthroughfourthpapercassettes):papertake-upmechanism	55	
(6) Universal paper cassette (first paper cassette): paper feed retry control	55	
(7) Lower feed unit (second through fourth paper cassettes): paper feed retry control	56	
(8) Universal paper cassette (first paper cassette): paper empty detection mechanism	57	
(9) Universal paper cassette (second through fourth paper cassettes): paper empty	detection mechanism	58
(10) Universal paper cassette (first through fourth paper cassettes): paper near-empty	detection mechanism	59
(11) Universal paper cassette: paper size detection mechanism	60	
4-3. Imaging cartridge	61	
(1) Overview	61	
(2) Toner empty detection	63	
4-4. Drum charging	65	
4-5. Laser exposure	66	
4-6. Development	67	
4-7. Image transfer	68	
4-8. Fusing section	69	

(1) Fusing temperature control circuit	70
(2) Heater lamp control	70
(3) Overview of temperature control modes during stand-by	71
(4) Temperature control mode during stand-by: mode 1	71
(5) Temperature control mode during stand-by: mode 2	71
(6) Temperature control mode during stand-by: mode 3	71
(7) Temperature control modes during printing	72
(8) Temperature control: software protection	73
(9) Temperature control: hardware protection	73
(10) Temperature control: overheat protection	73
4-9. Paper exit section	74
(1) Paper-full detection mechanism	75
(2) Paper output roller drive-switching mechanism	76
(3) Paper-output-switching mechanism	77
4-10. Duplex section (optional duplex unit)	78
(1) Overview	78
(2) Single-sided printing mechanism	79
(3) Double-sided printing mechanism	80
4-11. Sorting section (optional 4-bin mailbox)	81
(1) Drive mechanism	81
(2) Paper-switching mechanism	82
(3) Bin-switching mechanism	83
(4) Fed paper detection mechanism	84
(5) Full mailbin detection mechanism	84
5. MAINTENANCE/DISASSEMBLY	85
5-1. Precautions for maintenance/disassembly	85
(1) Precautions for disassembly	85
(2) Parts that must not be touched	85
(3) During transportation/storage the PWBs with MOS ICs:	85
(4) During replacement the PWBs with MOS ICs:	85
(5) During Inspection the PWBs with MOS ICs:	86
(6) During transportation/storage the imaging cartridge:	86
(7) Handling the imaging cartridge:	86
5-2. Cleaning schedule	87
5-3. Maintenance schedule	87
5-4. Required service tools	87
5-5. List of screws used	88
5-6. Printer disassembly procedures	89
(1) Disassembly procedure chart	89
(2) Pre-disassembly preparation 1 (removing the imaging cartridge)	90
(3) Pre-disassembly preparation 2 (removing the multi-purpose paper tray) ..	91
(4) Pre-disassembly preparation 3 (removing the first paper cassette)	92
(5) Pre-disassembly preparation 4 (removing the paper-full detection board) ..	93
(6) Pre-disassembly preparation 5 (removing the fusing unit)	94
(7) Replacing the exhaust filter	96
(8) Replacing the paper take-up roller of the multi-purpose paper tray	97

(9)	Replacing the toner empty detection board (PWB-G)	98
(10)	Replacing the paper empty sensor (PC4) and the paper near-empty sensor (PC5) for the multi-purpose paper tray	99
(11)	Replacing the paper take-up solenoid (SL1) of the multi-purpose tray	101
(12)	Replacing the paper empty sensor (PC6) for the first paper cassette	102
(13)	Replacing the paper take-up rollers and the paper-separating roller for the first paper cassette and the expansion paper cassettes	103
(14)	Replacing the heater (H1), thermostat (TS1), thermal fuse (TF1), thermistor 1 (TH1), and heat roller	107
(15)	Replacing the paper output sensor (PC3) of the fusing section	115
(16)	Replacing the image transfer roller unit	116
(17)	Replacing the new-imaging-cartridge detection board (PWB-D)	117
(18)	Removing the outer covers	118
(19)	Replacing the control panel	120
(20)	Removing the shield	121
(21)	Replacing thermistor 2 (TH2)	122
(22)	Replacing the humidity sensor (HS1)	122
(23)	Replacing the power supply unit fan motor	123
(24)	Replacing interlock switch 1 (S2)	124
(25)	Replacing the main control board (PWB-A)	125
(26)	Replacing the print head unit	127
(27)	Replacing the ozone fan motor (M6)	128
(28)	Replacing the power supply board (PU1)	129
(29)	Replacing the high voltage unit (HV1)	130
(30)	Replacing the power switch (S1)	131
(31)	Replacing interlock switch 2 (S3)	132
(32)	Replacing the main motor (M1) and imaging cartridge drive motor (M2)	133
(33)	Replacing the paper size detection switch (S4), the paper empty sensor (PC6), and the paper take-up clutch (CL2) for the first paper cassette	134
(34)	Replacing the fusing fan motor (M3)	136
(35)	Replacing the transport roller clutch (CL1) and the paper sensor (PC1) of the image transfer section	137
5-7.	Duplex unit disassembly procedures	139
(1)	Replacing the transport motor (M1), the switchback motor (M2), the control board (PWB-A), and the duplex cover switch (PC1)	139
5-8.	500-sheet lower feed unit disassembly procedures	141
(1)	Replacing the control board (PWB-A)	141
(2)	Replacing the paper take-up clutch (CL1) and the paper take-up motor (M1)	142
(3)	Replacing the paper sensor (PC1)	143
(4)	Replacing the paper empty sensor (PC2)	144
(5)	Replacing the paper size detection switch (S1) and the paper near-empty sensor (PC3)	145
5-9.	4-bin mailbox disassembly procedures	146
(1)	Replacing the lower transport sensor (PC9)	146
(2)	Replacing the sensors of mailbins 1 and 3	147
(3)	Replacing the sensors of mailbin 2	148

(4)	Replacing the sensors of mailbin 4 and the cover sensor	149
(5)	Replacing the set sensor (PC12) and the control board (PWB-A)	151
(6)	Replacing the transport motor (M1) and the solenoids	152
6.	ADJUSTMENT	155
6-1.	Adjustment of image registration	155
7.	TROUBLESHOOTING	157
7-1.	Paper misfeed detection	157
(1)	Detecting paper remaining in the machine	157
(2)	Detecting a paper misfeed while feeding	157
(3)	Operation when a paper misfeed is detected	158
(4)	Conditions under which a paper misfeed is detected	158
(5)	Procedure for resetting after a paper misfeed is detected	160
7-2.	Malfunction detection	161
(1)	Laser malfunction - Service Call 10 H-Sync	161
(2)	Polygon motor malfunction - Service Call 0A Polygon Motor	161
(3)	Fusing malfunctions Service Call 18 Fuser Warmup	161
(4)	Power supply unit fan motor malfunction Service Call 0C Power Supply	161
(5)	Ozone fan motor malfunction Service Call 0D Power Supply Fan 2	161
(6)	Fusing fan motor malfunction Service Call 0B Internal Fan	162
(7)	Image transfer voltage error Service Call 0F High Voltage	162
(8)	Main motor malfunction Service Call 08 Main Motor	162
(9)	Imaging cartridge drive motor malfunction Service Call 09 IC Motor	162
(10)	4-bin mailbox transmission error Service Call 02 I/F Communication	162
7-3.	Troubleshooting for paper misfeeds	163
(1)	Paper misfeed when the power switch is turned on	163
(2)	Paper misfeed between the paper feed-in section and the transport section	163
(3)	Paper misfeed between the transport section and the paper feed-out section	164
(4)	Paper jam display messages and associated sections	165
7-4.	Troubleshooting for operation malfunctions	166
(1)	Hardware errors	166
(2)	No power	166
7-5.	Image quality troubleshooting	167
	INDEX	171

1. SAFETY PRECAUTIONS FOR INSPECTION AND SERVICE

1-1. Outlines of safety precautions

When performing inspection and service procedures, observe the following precautions to prevent accidents and ensure utmost safety.

* Depending on the model, some of the precautions given do not apply.

Different markings are used to denote specific meanings as detailed below.



WARNING

Indicates a potentially hazardous situation which, if not avoided, could result in death or serious injury.



CAUTION

Indicates a potentially hazardous situation which, if not avoided, may result in minor or moderate injury. It may also be used to alert against unsafe practices.

The following graphic symbols are used to give instructions that need to be observed.



Used to call the service technician's attention to what is graphically represented inside the marking (including a warning).



Used to prohibit the service technician from doing what is graphically represented inside the marking.



Used to instruct the service technician to do what is graphically represented inside the marking.

1-2. Warning



WARNING

1. Always observe precautions.



- Parts requiring special attention in this product include a label containing the mark shown on the left plus precautionary notes. Be sure to observe the precautions.
- Be sure to observe the "Safety Information" given in the Operator's Manual.

2. Before starting any procedures, be sure to unplug the power cord.



- This product contains a high-voltage unit and a circuit with a large current capacity that may cause an electric shock or burn.
- The product also contains parts that can jerk suddenly and cause injury.
- This product uses a laser. Laser beam leakage may cause eye damage or blindness.

3. Use the specified parts



- For replacement parts, always use the genuine parts specified in the manufacturer's parts manual. Installing a wrong or unauthorized part could cause dielectric breakdown, overload, or undermine safety devices, resulting in possible electrical shock or fire.
- Replace a blown electrical fuse or thermal fuse with its corresponding genuine part specified in the manufacturer's parts manual. Installing a fuse of a different make or rating could lead to a possible fire. If a thermal fuse blows frequently, the temperature control system may have a problem and action must be taken to eliminate the cause of the problem.

4. Handle the power cord with care and never use a multiple outlet.



- Do not break, crush or otherwise damage the power cord. Placing a heavy object on the power cord, or pulling or bending it may damage it, resulting in a possible fire or electrical shock.
- Do not use a multiple outlet to which any other appliance or machine is connected.
- Be sure the power outlet meets or exceeds the specified capacity.

5. Be careful with the high-voltage parts.



- A part marked with the symbol shown on the left carries a high voltage. Touching it could result in an electrical shock or burn. Be sure to unplug the power cord before servicing this part or the parts near it.

6. Do not work with wet hands.



- Do not unplug or plug in the power cord, or perform any kind of service or inspection with wet hands. Doing so could result in an electrical shock.

7. Do not touch a high-temperature part.



- A part marked with the symbol shown on the left and other parts such as the exposure lamp and fusing roller can be very hot while the machine is energized. Touching them may result in a burn.
- Wait until these parts have cooled down before replacing them or any surrounding parts.

8. Maintain a grounded connection at all times. (This item may not apply in the USA.)



- Be sure to connect the ground wire to the ground terminal even when performing an inspection or repair. Without proper grounding, electrical leakage could result in an electrical shock or fire.
- Never connect the ground wire to a gas pipe, water pipe, telephone ground wire, or a lightning conductor.

9. Do not modify the product.



- Modifying this product in a manner not authorized by the manufacturer may result in a fire or electrical shock. If this product uses a laser. Laser beam leakage may cause eye damage or blindness.

10. Restore all parts and harnesses to their original positions.



- To promote safety and prevent product damage, make sure the harnesses are returned to their original positions and properly secured in their clamps and saddles in order to avoid hot parts, high-voltage parts, sharp edges, or being crushed.
- To promote safety, make sure that all tubing and other insulating materials are returned to their original positions. Make sure that floating components mounted on the circuit boards are at their correct distance and position off the boards.

1-3. Caution



CAUTION

1. Precautions for Service Jobs



- A toothed washer and spring washer, if used originally, must be reinstalled. Omitting them may result in contact failure which could cause an electric shock or fire.
- When reassembling parts, make sure that the correct screws (size, type) are used in the correct places. Using the wrong screw could lead to stripped threads, poorly secured parts, poor insulating or grounding, and result in a malfunction, electric shock or injury.
- Take great care to avoid personal injury from possible burrs and sharp edges on the parts, frames and chassis of the product.



- When moving the product or removing an option, use care not to injure your back or allow your hands to be caught in mechanisms.

2. Precautions for Servicing with Covers and Parts Removed



- Wherever feasible, keep all parts and covers mounted when energizing the product.
- If energizing the product with a cover removed is absolutely unavoidable, do not touch any exposed live parts and use care not to allow your clothing to be caught in the moving parts. Never leave a product in this condition unattended.
- Never place disassembled parts or a container of liquid on the product. Parts falling into, or the liquid spilling inside, the mechanism could result in an electric shock or fire.
- Never use a flammable spray near the product. This could result in a fire.
- Make sure the power cord is unplugged before removing or installing circuit boards or plugging in or unplugging connectors.



- Always use the interlock switch actuating jig to actuate an interlock switch when a cover is opened or removed. The use of folded paper or some other object may damage the interlock switch mechanism, possibly resulting in an electric shock, injury or blindness.

3. Precautions for the Working Environment



- The product must be placed on a flat, level surface that is stable and secure.
- Never place this product or its parts on an unsteady or tilting workbench when servicing.
- Provide good ventilation at regular intervals if a service job must be done in a confined space for a long period of time.
- Avoid dusty locations and places exposed to oil or steam.
- Avoid working positions that may block the ventilation ports of the product.

4. Precautions for Handling Batteries (Lithium, Nickel-Cadmium, etc.)



- Replace a rundown battery with the same type as specified in the manufacturer's parts manual.
- Before installing a new battery, make sure of the correct polarity of the installation or the battery could burst.
- Dispose of used batteries according to the local regulations. Never dispose of them at the user's premises or attempt to try to discharge one.

5. Precautions for the Laser Beam (Only for Products Employing a Laser)



- Removing the cover marked with the following caution label could lead to possible exposure to the laser beam, resulting in eye damage or blindness. Be sure to unplug the power cord before removing this cover.
- If removing this cover while the power is ON is unavoidable, be sure to wear protective laser goggles that meet specifications.
- Make sure that no one enters the room when the machine is in this condition.
- When handling the laser unit, observe the "Precautions for Handling Laser Equipment."

1-4. Other precautions

Other Precautions

- When handling circuit boards, observe the “HANDLING of PWBs.”
- The PC Drum is a very delicate component. Observe the precautions given in “HANDLING OF THE PC DRUM” because mishandling may result in serious image problems.
- Note that replacement of a circuit board may call for readjustments or resetting of particular items, or software installation.

Used Batteries Precautions

ALL Areas

CAUTION

Danger of explosion if battery is incorrectly replaced.

Replace only with the same or equivalent type recommended by the manufacturer.

Dispose of used batteries according to the manufacturer’s instructions.

Germany

VORSICHT!

Explosionsgefahr bei unsachgemäßem Austausch der Batterie.

Ersatz nur durch denselben oder einen vom Hersteller empfohlenen gleichwertigen Typ.

Entsorgung gebrauchter Batterien nach Angaben des Herstellers.

France

ATTENTION

Il y a danger d’explosion s’il y a remplacement incorrect de la batterie.

Remplacer uniquement avec une batterie du même type ou d’un type équivalent recommandé par le constructeur.

Mettre au rebut les batteries usagées conformément aux instructions du fabricant.

Denmark

ADVARSEL!

Lithiumbatteri - Eksplosionsfare ved fejlagtig håndtering.

Udskiftning må kun ske med batteri af samme fabrikat og type.

Lever det brugte batteri tilbage til leverandøren.

Finland, Sweden

VAROITUS

Paristo voi räjähtää, jos se on virheellisesti asennettu.

Vaihda paristo ainoastaan laitevalmistajan suosittelemaan tyyppiin.

Hävittä käytetty paristo valmistajan ohjeiden mukaisesti.

WARNING

Explosionsfara vid felaktigt batteribyte.

Använd samma batterityp eller en ekvivalent typ som rekommenderas av apparattillverkaren.

Kassera använt batteri enligt fabrikantens instruktion.

Norway

ADVARSEL

Eksplosjonsfare ved feilaktig skifte av batteri.

Benytt samme batteritype eller en tilsvarende type anbefalt av apparatfabrikanten.

Brukte batterier kasseres i henhold til fabrikantens instruksjoner.

1

SAFETY PRECAUTIONS FOR INSPECTION AND SERVICE

1-5. Precautions for service

When performing inspection and service procedures, observe the following precautions to prevent mishandling of the machine and its parts.

* Depending on the model, some of the precautions do not apply.

Precautions Before Service

- When the user is using a word processor or personal computer from a wall outlet of the same line, take necessary steps to prevent the circuit breaker from opening due to overloads.
- Never disturb the LAN by breaking or making a network connection, altering termination, installing or removing networking hardware or software, or shutting down networked devices without the knowledge and express permission of the network administrator or the shop supervisor.

How to Use this Book

1. DIS/REASSEMBLY, ADJUSTMENT

- To reassemble the product, reverse the order of disassembly unless otherwise specified.

2. TROUBLESHOOTING

- If a component on a PWB or any other functional unit including a motor is defective, the text only instructs you to replace the whole PWB or functional unit and does not give troubleshooting procedures applicable within the defective unit.
- All troubleshooting procedures contained herein assume that there are no breaks in the harnesses and cords and all connectors are plugged into the right positions.
- The procedures preclude possible malfunctions due to noise and other external causes.

Precautions for Service

- Check the area surrounding the service site for any signs of damage, wear or need of repair.
- Keep all disassembled parts in good order and keep tools under control so that none will be lost or damaged.
- After completing a service job, perform a safety check. Make sure that all parts, wiring and screws are returned to their original positions.
- Do not pull out the toner hopper while the toner bottle is turning. This could result in a damaged motor or locking mechanism.
- If the product is to be run with the front door open, make sure that the toner hopper is in the locked position.
- Do not use an air gun or vacuum cleaner for cleaning the ATDC Sensor and other sensors, as they can cause electrostatic destruction. Use a blower brush and cloth. If a unit containing these sensors is to be cleaned, first remove the sensors from the unit.

Precautions for Dis/Reassembly

- Be sure to unplug the printer from the outlet before attempting to service the printer.
- The basic rule is not to operate the printer anytime during disassembly. If it is absolutely necessary to run the printer with its covers removed, use care not to allow your clothing to be caught in revolving parts such as the timing belt and gears.
- Before attempting to replace parts and unplug connectors, make sure that the power cord of the printer has been unplugged from the wall outlet.
- While the product is energized, do not unplug or plug connectors into the circuit boards or harnesses.
- Never use flammable sprays near the printer.
- A used battery should be disposed of according to the local regulations and never be discarded casually or left unattended at the user's premises.
- When reassembling parts, make sure that the correct screws (size, type) and toothed washer are used in the correct places.
- If it becomes necessary to replace the thermal fuse or any other fuse mounted on a board, be sure to use one of the rating marked on the blown fuse. Always note the rating marked on the fuse, as the rating and mounting site or number used are subject to change without notice.

Precautions for Circuit Inspection

- Never create a closed circuit across connector pins except those specified in the text and on the printed circuit.
- When creating a closed circuit and measuring a voltage across connector pins specified in the text, be sure to use the GND wire.

Handling of PWBs

1. During Transportation/Storage:

- During transportation or when in storage, new P.W. Boards must not be indiscriminately removed from their protective conductive bags.
- Do not store or place P.W. Boards in a location exposed to direct sunlight and high temperature.
- When it becomes absolutely necessary to remove a Board from its conductive bag or case, always place it on its conductive mat in an area as free as possible from static electricity.
- Do not touch the pins of the ICs with your bare hands.
- Protect the PWBs from any external force so that they are not bent or damaged.

2. During Inspection/Replacement:

- Avoid checking the IC directly with a multimeter; use connectors on the Board.
- Never create a closed circuit across IC pins with a metal tool.
- Before unplugging connectors from the P.W. Boards, make sure that the power cord has been unplugged from the outlet.
- When removing a Board from its conductive bag or conductive case, do not touch the pins of the ICs or the printed pattern. Place it in position by holding only the edges of the Board.
- When touching the PWB, wear a wrist strap and connect its cord to a securely grounded place whenever possible. If you cannot wear a wrist strap, touch a metal part to discharge static electricity before touching the PWB.

- Note that replacement of a PWB may call for readjustments or resetting of particular items.

Handling of Other Parts

- The magnet roller generates a strong magnetic field. Do not bring it near a watch, floppy disk, magnetic card, or CRT tube.

Handling of the Imaging Cartridge

* Only for Products Employing an Imaging Cartridge.

1. During Transportation/Storage:

- The storage temperature is in the range between -20°C and $+40^{\circ}\text{C}$.
- In summer, avoid leaving the Imaging Cartridge in a car for a long time.

2. Handling:

- Store the Imaging Cartridge in a place that is not exposed to direct sunlight.

3. Precautionary Information on the PC Drum Inside the Imaging Cartridge:

- Use care not to contaminate the surface of the PC Drum with oil-base solvent, fingerprints, and other foreign matter.
- Do not scratch the surface of the PC Drum.
- Do not attempt to wipe clean the surface of the PC Drum.

4. Be sure to keep the imaging cartridge out of the reach of children. Ingesting contents of the imaging cartridge is harmful to your health.



WARNING



Do not throw toner or the toner bottle into a fire. Toner expelled from the fire may cause burns.

1-6. Safety information

(1) Laser Safety

- This is a digital machine certified as a Class 1 laser product. There is no possibility of danger from the laser, provided the machine is serviced according to the instructions in this manual.

(2) Internal Laser Radiation

semiconductor laser specifications	
Maximum power of the laser diode	15 mW
Maximum average radiation power	37 μ W (at laser aperture of mirror unit)
	70 μ W (at laser Aperture of print head unit)
Wavelength	775-795 nm

- This product employs a Class 3b laser diode that emits an invisible laser beam.
- The print head section consists of two units: the print head unit and the mirror unit. The laser diode and a polygon mirror are incorporated into the print head unit. A laser-beam-reflecting mirror is incorporated into the mirror unit.
- The laser beam is emitted from the print head unit, passes through the mirror unit, then is radiated into the interior of the printer through the laser aperture of the mirror unit.
- The print head section (print head unit and mirror unit) is not a field service item. Therefore, it must not be disassembled or adjusted under any circumstance.

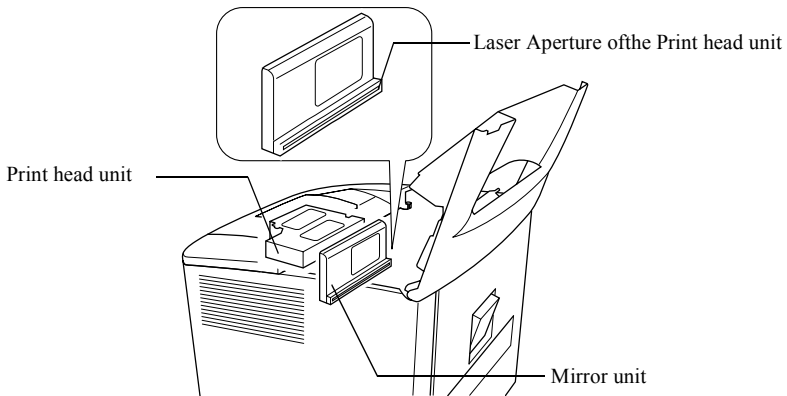

This figure shows the view inside the Rear Upper Cover with the Imaging Cartridge removed.

**the USA, Canada
(CDRH Regulation)**

- This machine is certified as a Class I Laser product under Radiation Performance Standard according to the Food, Drug and Cosmetic Act of 1990. Compliance is mandatory for Laser products marketed in the United States and is reported to the Center for Devices and Radiological Health (CDRH) of the U.S. Food and Drug Administration of the U.S. Department of Health and Human Services (DHHS). This means that the device does not produce hazardous laser radiation.
- The label shown to page 22 indicates compliance with the CDRH regulations and must be attached to laser products marketed in the United States.

CAUTION

Use of controls, adjustments or performance of procedures other than those specified in this manual may result in hazardous radiation exposure.

Semiconductor laser	
Maximum power of the laser diode	15 mW
Wavelength	775-795 nm

All Areas

CAUTION

Use of controls, adjustments or performance of procedures other than those specified in this manual may result in hazardous radiation exposure.

Semiconductor laser	
Maximum power of the laser diode	15 mW
Wavelength	775-795 nm

Denmark

ADVARSEL

Usynlig laserstråling ved åbning, når sikkerhedsafbrydere er ude af funktion.
Undgå udsættelse for stråling. Klasse 1 laser produkt der opfylder IEC60825 sikkerheds kravene.

Halvlederlaser	
Laserdiodens højeste styrke	15 mW
bølgelængden	775-795 nm

Finland, Sweden

LUOKAN 1 LASERLAITE
KLASS 1 LASER APPARAT

VAROITUS!

Laitteen käyttäminen muulla kuin tässä käyttöohjeessa mainitulla tavalla saattaa altistaa käyttäjän turvallisuusluokan 1 ylittävälle näkymättömälle lasersäteilylle.

Puolijohdelaser	
Laserdiodin suurin teho	15 mW
Aallonpituus	775-795 nm

WARNING!

Om apparaten används på annat sätt än i denna bruksanvisning specificerats, kan användaren utsättas för osynlig laserstrålning, som överskrider gränsen för laserklass 1.

halvledarlaser	
Den maximala effekten för laserdioden	15 mW
våglängden	775-795 nm

VARO!

Avattaessa ja suojalukitus ohitettaessa olet alttiina näkymättömälle lasersäteilylle. Älä katso säteeseen.

WARNING!

Osynlig laserstrålning när denna del är öppnad och spärren är urkopplad. Betrakta ej strålen.

Norway

ADVERSEL

Dersom apparatet brukes på annen måte enn spesifisert i denne bruksanvisning, kan brukeren utsettes for usynlig laserstrålning, som overskrider grensen for laser klass 1.

Halvleder laser	
Maksimal effekt till laserdiode	15 mW
Bølgelengde	775-795 nm

2. INSTALLATION

2-1. Installation environment

When installing the printer, please avoid the types of locations listed below, both for safety considerations and to avoid breakdowns.

- Areas with high temperatures or humidity, or with low temperatures and humidity.
- Areas where the temperature and/or humidity fluctuate sharply.
- Places where the printer will be in direct sunlight.
- Areas near a cooler, heater, ventilation opening or in the direct path of wind.
- Areas near oil stoves or other heat-generating equipment.
- Locations with poor ventilation.
- Areas where water is likely to fall on the equipment or electrical leakage is likely.
- Areas where corrosive gases (ammonia gases, etc.) are present.
- Areas where there is a high volume of dust, dirt and vibration.
- Areas where the floor is not sufficiently strong or is not level.
- Areas containing volatile and flammable materials and curtains.

Warning

Two people are required to lift the printer. Hold it as shown in the illustration. Be careful not to strain your back when lifting the printer.

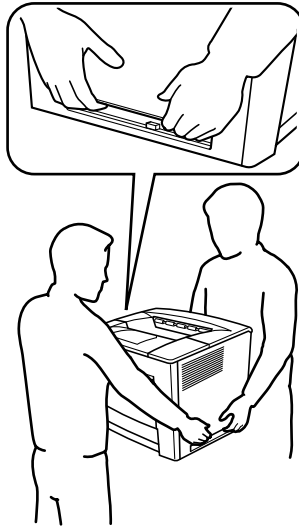

2-2. Usage environment

In order to make sure the printer operates properly, please make sure the ambient environment satisfies the following requirements:

Temperature	10-35°C ;50 °F-95 °F
Temperature fluctuation	±10°C or ±18°F per hour or less
Humidity	15-85%RH
Humidity fluctuation	±20% RH per hour or less

2-3. Installing the power supply

- Do not plug the power cord into a power outlet via an extension cord supplying electricity to more than one unit.
- Do not connect the printer to a power outlet used for other equipment or appliances. More than one appliance connected to a single outlet could cause a drop or surge in the electrical supply, resulting in operational problems for the printer.

Voltage fluctuation	Specified voltage: ±10%
Frequency fluctuation	Specified frequency: ±3Hz

The following items should be checked periodically:

- Make sure the power supply plugs do not feel warm.
- Power supply cords should be free of cracks and scratches.
- Power supply plugs should be firmly plugged into outlets.

2-4. Space requirements

(1) Standard

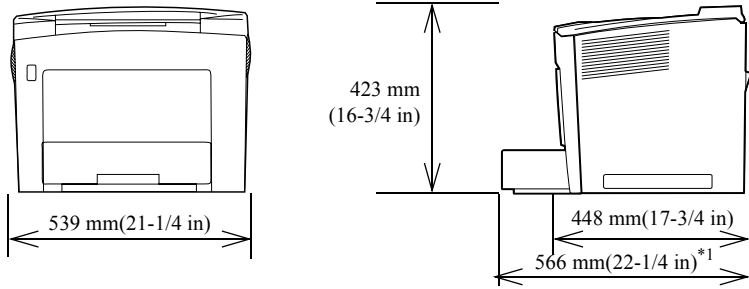

(2) With options installed

Installed options: Lower feeder unit (3 levels), duplex unit, and 4-bin mailbox.

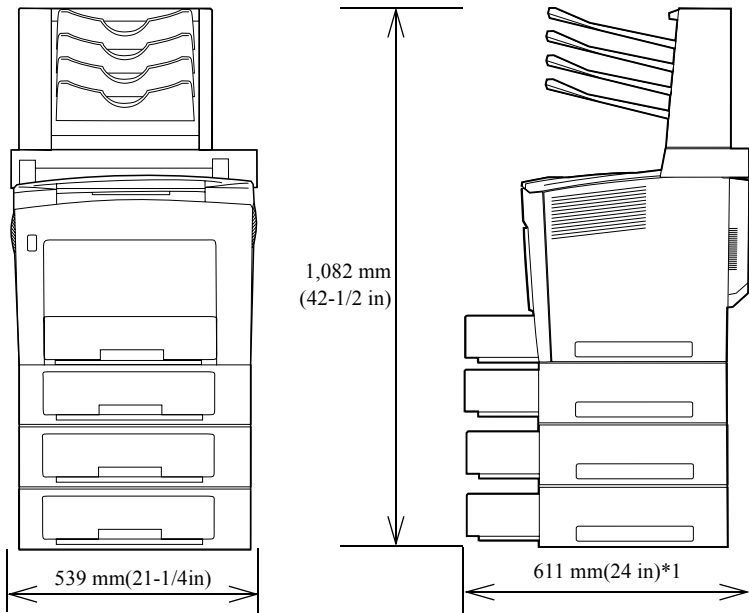

*1: With the media trays installed

3. GENERAL INFORMATION

3-1. Specifications

(1) Printer

Type	Desktop laser beam printer
Exposure method	Laser diode + Polygon mirror scanning
Printing method	Electrophotographic
Print resolution	600 dpi (dots/inch)
Media sizes	<p>A5 to A3/Half Letter to Ledger</p> <p>A3 (297 mm × 420 mm/11.7" × 16.5")</p> <p>B4 (257 mm × 364 mm/10.1" × 14.3")</p> <p>Folio (210 mm × 330 mm/8.27" × 13")*</p> <p>A4 (210 mm × 297 mm/8.2" × 11.7")</p> <p>JIS-B5 (182 mm × 257 mm/7.2" × 10.1")</p> <p>ISO-B5 (176 mm × 250 mm/6.6" × 9.8")*</p> <p>A5 (148 mm × 210 mm/5.9" × 8.3")*</p> <p>Ledger (279.4 mm × 432 mm/11" × 17")</p> <p>Legal (215.9 mm × 355.6 mm/8.5" × 14")</p> <p>G-Legal (215.9 mm × 330.2 mm/8.5 × 13)*</p> <p>Letter (215.9 mm × 279.4 mm/8.5" × 11")</p> <p>G-Letter (203.2 mm × 266.7 mm/8" × 10.5")</p> <p>Executive (184.15 mm × 266.7 mm/7.25" × 10.5")*</p> <p>Statement (139.7 mm × 215.9 mm/5.5" × 8.5")*¹,</p> <p>Japanese Postcard (100 mm × 148 mm/3.9" × 5.8")*</p> <p>Com 10 (105 mm × 241.3 mm/4.1" × 9.5")*</p> <p>DL (110 mm × 220 mm/4.3" × 8.7")*</p> <p>Monarch (98 mm × 191 mm/3.9" × 7.5")</p> <p>C5 (162 mm × 229 mm/6.4" × 9")*</p> <p>C6 (114 mm × 162 mm/4.5" × 6.4")*</p> <p>8 Kai (260 mm × 370 mm/10.24" × 14.57")*</p> <p>16 Kai (185 mm × 260 mm/7.3" × 10.24")*</p> <p>32 Kai (130 mm × 185 mm/5.12" × 7.3")*</p> <p>*¹ Multipurpose paper tray only</p>
Media types	<p>Plain paper (60 to 90 g/m²; 16 to 24 lbs.)</p> <p>Recycled paper (60 to 90 g/m²; 16 to 24 lbs.)</p> <p>Transparencies*, Letterheads*, Envelopes*, Label sheets*</p> <p>Thick paper* (91 to 163 g/m²; 24 to 43 lbs.), Post cards*</p> <p>*¹ Multipurpose paper tray only</p>

First-page print time	Single-sided prints Multipurpose paper tray: Less than 10 seconds * Universal paper cassette: Less than 10 seconds * Double-sided prints Multipurpose paper tray*: Less than 15 seconds * Universal paper cassette*: Less than 14.5 seconds * * ² With A4 or Letter paper.
Multi-page print speed	Single-sided prints Multipurpose paper tray/A4: 35 ppm Multipurpose paper tray/Letter: 34.5 ppm Double-sided prints Multipurpose paper tray/A4: 26 ppm Multipurpose paper tray/Letter: 25.6 ppm
Warm-up time	Less than 70 seconds* Recovery time from power save mode: Within 30 seconds* * ³ At a room temperature of 23 °C (73.4 °F) and at the rated voltage
System speed	160.0 mm/s
Paper feed-in method	2-way (maximum 5-way)* Multipurpose paper tray Universal paper cassette Lower feeder unit (optional)* * ⁴ Can be expanded to as much as a 5-way system by installing up to three optional Lower feeder units
Paper capacity	Multipurpose paper tray When using paper with a weight of 16 to 90 lbs (60 - 163 g/m ²): 200 sheets Universal paper cassette When using paper with a weight of 16 to 24 lbs (60 - 90 g/m ²): 500 sheets With recommended paper
Paper feed-out	Face-down Output tray capacity When using paper with a weight of 16 to 24 lbs (60 - 90 g/m ²): 500 sheets With recommended paper
Drum-charging method	Needle electrode/scorotron system
Developing method	Single-element developing system (S MicroToning developing system)
Development density control	Bias adjustment system
Image transfer method	Roller transfer system
PC Drum	OPC (Organic Photoconductor)
PC Drum cleaning method	Blade system
Paper separation	Mechanical separation by means of paper separator fingers
Fusing method	Heated roller fusing system

Dimensions	Standard configuration Width: 539 mm(21-1/4 in) Depth: 448 mm(17-3/4 in) with out the Universal paper cassette 566 mm(22-1/4 in) with the Universal paper cassette installed Height: 423 mm(16-3/4 in)
Dimensions	With options installed (with three Lower feeder unit and the duplex unit installed) Width: 539 mm(21-1/4 in) Depth: 611 mm(24 in) Height: 762 mm(30 in) With options installed (with three lower feeder units, the duplex unit and the 4-bin mailbox installed) Width: 539 mm(21-1/4 in) Depth: 611 mm(24 in) Height: 1,082 mm(42-1/2 in)
Weight	28.0 kg(61-3/4 lbs.) or less* Imaging cartridge: Approx. 2.5 kg(5-1/2 lbs.) * ⁵ Weight of the standard configuration does not include the imaging cartridge.
Rated input power supply voltage	AC 120 V (operation guaranteed) AC 230 V (operation guaranteed)
Frequency	50/60 Hz ±3 Hz
Amperage	AC 120 V :10A or less AC 230 V :5A or less
Power consumption	Maximum power consumption: 1,150 W or less* Average power consumption while printing: 850 W or less Average power consumption during stand-by: 350 W or less Average power consumption with the heater off: 40 W or less Average power consumption in power save mode: 150 W or less * ⁶ At a room temperature of 23 °C(73.4 °F); except when the heater is on
Acoustic noise	During stand-by: 38 dB or less* While printing: 57 dB or less* * ⁷ Average sound level in four directions with the standard configuration
Operating environment	Temperature 10 to 35 °C(50 to 95 °F) Humidity 15-85%RH
Imaging cartridge life	Start-up imaging cartridge: Average 6,000 or more printer (multi-page printing; black/white ratio=5%) Replacement imaging cartridge: Average 15,000 or more prints (multi-page printing; black/white ratio=5%)
Standard accessories (one each)	Power cord Imaging cartridge
Options	Lower feeder unit (Up to 3 can be installed) Duplex unit 4-bin Mailbox

(2) 500-sheet lower feed unit (optional)

Name	500-Sheet lower feed unit
Type	Expansion paper feed unit (stacking type)
Installation method	Secured at the top/bottom
Media types	Plain paper 16 to 24 lbs (60 - 90 g/m ²), Recycled paper 16 to 24 lbs (60 - 90 g/m ²)
Media sizes	Universal A3 (297 mm × 420 mm/11.7" x 16.5") B4 (257 mm × 364 mm/10.1" x 14.3") A4 (210 mm × 297 mm/8.2" x 11.7") JIS-B5 (182 mm × 257 mm/7.2" x 10.1") Ledger (279.4 mm x 432 mm/11" × 17") Legal (215.9 mm x 355.6 mm/8.5" × 14") Letter (215.9 mm x 279.4 mm/8.5" × 11") G-Letter (203.2 mm x 266.7 mm/8" × 10.5") G-Legal (215.9 mm x 330.2 mm/8.5 × 13)
Paper cassette capacity	When using paper with a weight of 16 to 24 lbs (60 - 90 g/m ²): 500 sheets
Paper separation mechanism in the paper feed-in section	Pathway roller paper separation system with torque limiter
Power source	Supplied by the printer (DC24 V, DC5 V)
Drive source	Step motor
Dimensions	Width: 512 mm(20-1/4 in) Depth: 551 mm(21-3/4 in) Height: 134 mm(5-1/4 in); 110 mm(4-1/4 in) /unit when stacked
Weight	Approx. 9.2 kg(20-1/4 lbs.)
Standard accessories	Universal paper cassette

(3) Duplex unit (optional)

Name	Duplex unit
Type	Reverse-circulating sheet-refeeding mechanism
Installation method	Attached to the back of the printer
Media types	Plain paper 16 to 24 lbs (60 - 90 g/m ²) Recycled paper 16 to 24 lbs (60 - 90 g/m ²)
Media sizes	A3 (297 mm × 420 mm/11.7" × 16.5") B4 (257 mm × 364 mm/10.1" × 14.3") A4 (210 mm × 297 mm/8.2" × 11.7") JIS-B5 (182 mm × 257 mm/7.2" × 10.1") A5 (148 mm × 210 mm/5.9" × 8.3")* ¹ Ledger (279.4 mm x 432 mm/11" × 17") Legal (215.9 mm x 355.6 mm/8.5" × 14") G-Legal (215.9 mm x 330.2 mm/8.5 × 13) Letter (215.9 mm x 279.4 mm/8.5" × 11") G-Letter (203.2 mm x 266.7 mm/8" × 10.5") Executive (184.15 mm x 266.7 mm/7.25" × 10.5")* Statement (139.7 mm x 215.9 mm/5.5" × 8.5")* * ¹ Multipurpose paper tray only
Power source	Supplied by the printer(DC24 V, DC5 V)
Drive source	Step motor
Dimensions	Width: 100 mm (4 in) Depth: 415 mm (16-1/4 in) Height: 280 mm (11 in)
Weight	Approx. 2.0 kg (4-1/2 lbs.)

(4) 4-bin mailbox (optional)

Name	4-bin mailbox
Installation method	Attached to the top of the printer
Number of mailbins	4 mailbins
Capacity per mail-bin	50 sheets (80 g/m ² ;21-1/4 lbs.)
media types	Plain paper 16 to 24 lbs (60 - 90 g/m ²), Recycled paper 16 to 24 lbs (60 - 90 g/m ²)
media sizes	B5 to A3/Letter to Ledger
Power source	Supplied by the printer (DC24 V, DC5 V)
Dimensions	Width: 513 mm (20-1/4 in) Depth: 159 mm (6-1/4 in) Height: 335 mm (13-1/4 in)
Weight	5.5 kg(12 lbs.) or less (with out the Transport unit) Transport unit: 3.0 kg (6-1/2 lbs.) or less

3-2. Parts identification

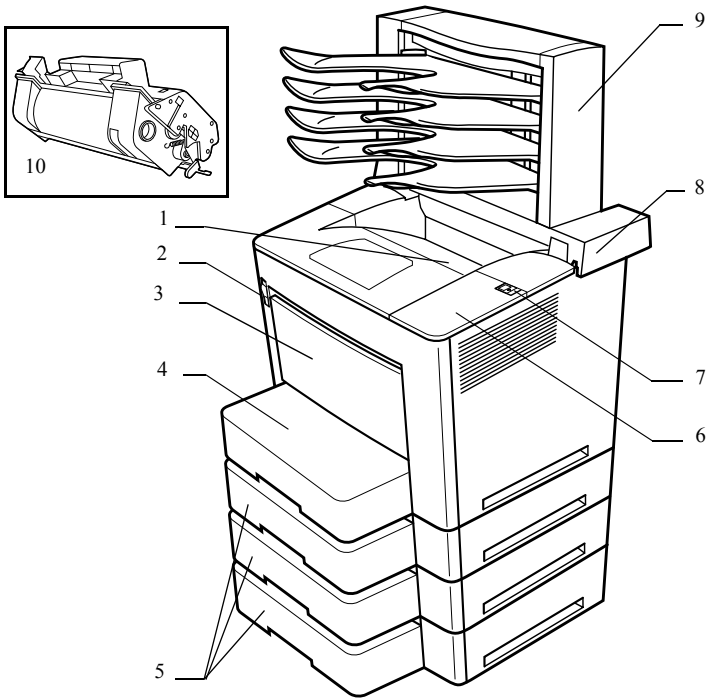

- 1 Face-down output tray
- 2 Power switch (S1)
- 3 Multipurpose paper tray (MP paper tray)
- 4 Universal paper cassette (first paper cassette)
- 5 Lower feeder unit (second through fourth media trays (optional))
- 6 Control panel
- 7 Top rear cover release button
- 8 Transport unit (optional)
- 9 4-bin mailbox (optional)
- 10 Imaging cartridge (IC)

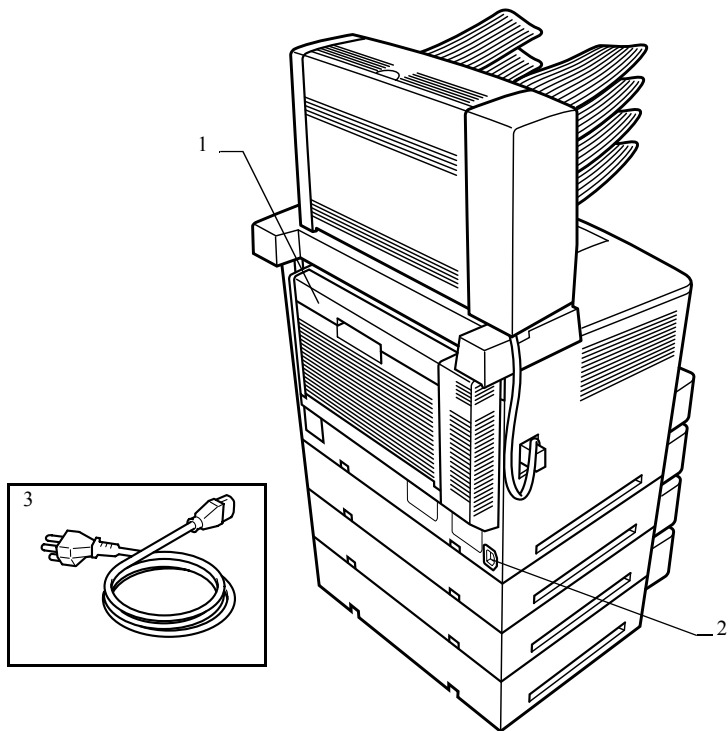

- 1 Duplex unit (optional)
- 2 Power cord socket
- 3 Power cord

3-3. Component diagram

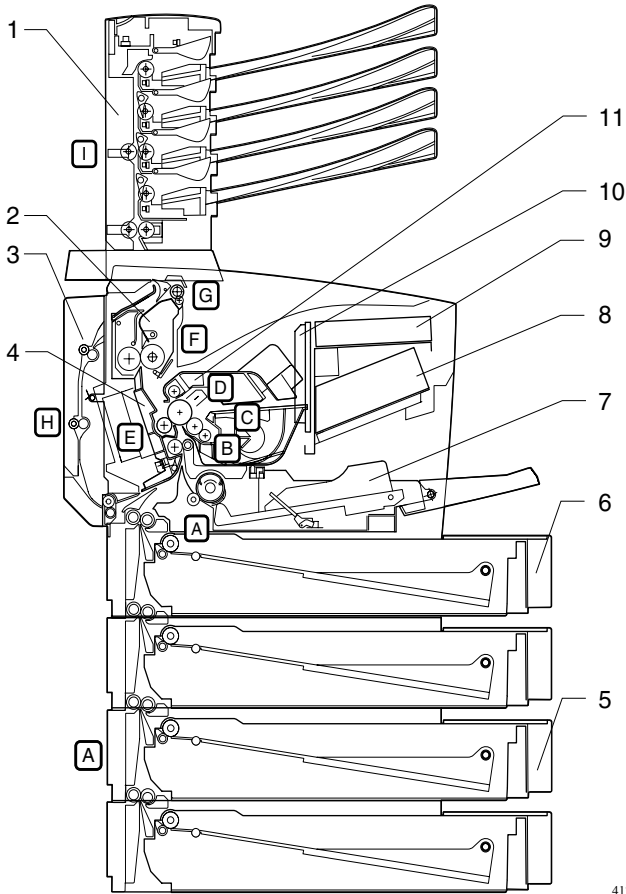

4128G548AA

- | | |
|--------------------------|-------------------------------------|
| A Paper take-up section | 1 4-bin mailbox |
| B Developing section | 2 Fusing unit |
| C Exposure section | 3 Duplex unit |
| D Drum-charging section | 4 Image transfer unit |
| E Image transfer section | 5 second through fourth media trays |
| F Fusing section | 6 first paper cassette |
| G Paper exit section | 7 Multipurpose paper tray |
| H Duplex section | 8 Power supply unit |
| I Sorting section | 9 Print head unit |
| | 10 Mirror unit |
| | 11 Imaging cartridge |

3-4. Drive system

(1) Overview of the drive system for the standard configuration

- The rollers in the imaging cartridge are driven by the imaging cartridge drive motor (M2).
- The rollers of the Multipurpose paper tray, first paper cassette, image transfer unit, and fusing unit are driven by the main motor (M1) via the corresponding gears.

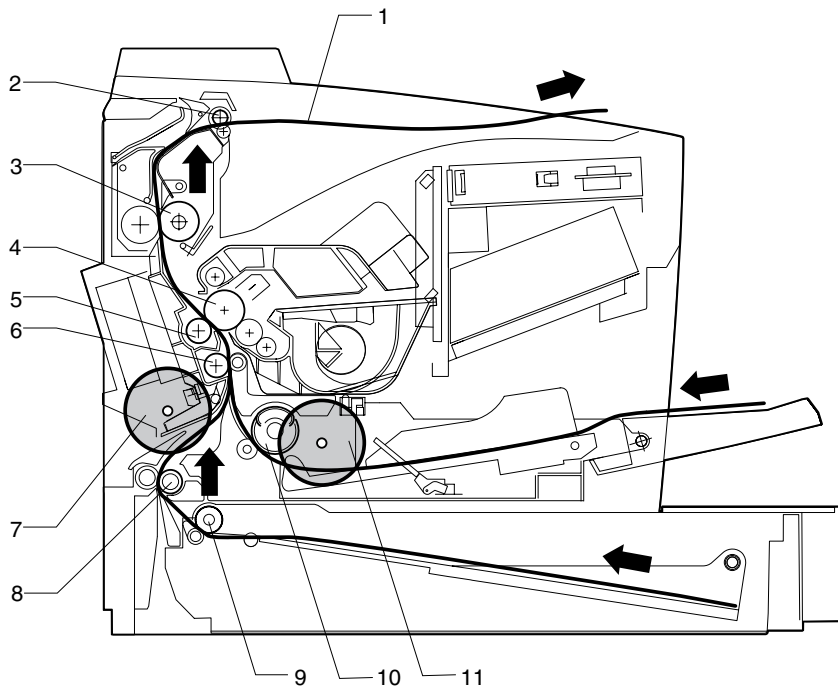

- 1 Paper
- 2 Paper output roller
- 3 Heat roller
- 4 PC Drum
- 5 Image transfer roller
- 6 Registration roller (image transfer section)
- 7 Main motor (M1)
- 8 Transport roller
- 9 Paper take-up roller for the first paper cassette
- 10 Paper take-up roller for the Multipurpose paper tray
- 11 Imaging cartridge drive motor (M2)

(2) Diagram of the drive system for the standard configuration

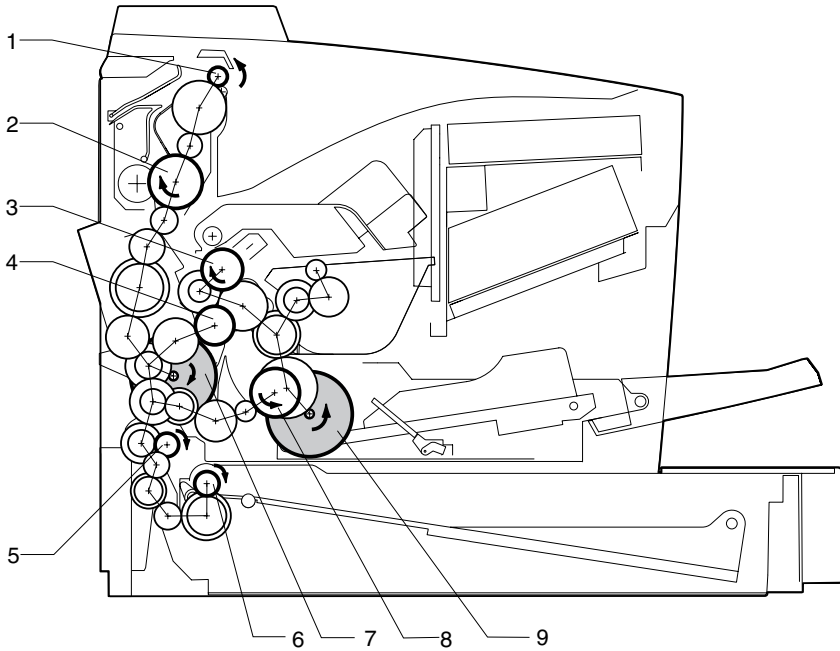

- 1 Paper output roller
- 2 Heat roller
- 3 PC Drum
- 4 Transport roller clutch of the image transfer section
- 5 Transport roller of the paper feed-in section
- 6 Paper take-up roller for the first paper cassette
- 7 Main motor (M1)
- 8 Paper take-up roller for the multipurpose paper tray
- 9 Imaging cartridge drive motor (M2)

(3) Overview of the drive system when options are installed

- The second through fourth Lower feeder units are equipped with motors for transporting paper (paper take-up motor M1). When transporting paper from an optional paper cassette, the paper take-up roller and transport roller of the optional paper cassette are driven by the paper take-up motor installed in the paper cassette unit. In addition, when printing from a lower optional paper cassette, the paper take-up motors of the upper optional paper cassette units also drive their transport rollers. For example, when printing from the fourth optional paper cassette, the paper take-up motors of the second and third lower feeder units also drive their transport rollers.
- By installing the optional duplex unit, the drive source for the paper output roller in the printer's fusing unit is switched from the main motor (M1) of the printer to the switchback motor (M2) of the duplex unit.
- The transport rollers and the feed-back roller of the duplex unit are driven by the transport motor (M1) of the duplex unit.
- The bin output roller and the transport rollers of the 4-bin mailbox are driven by the transport motor (M1) of the 4-bin mailbox.

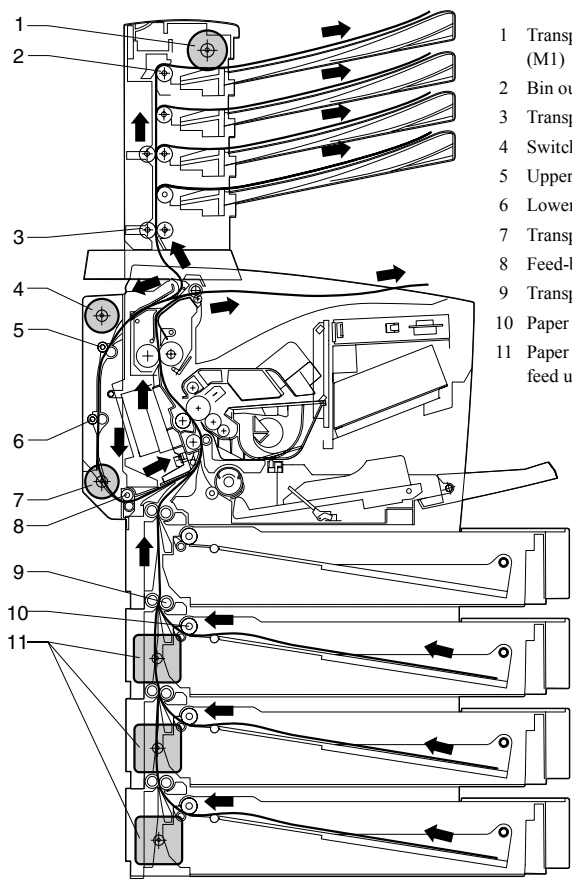

- 1 Transport motor of the 4-bin mailbox (M1)
- 2 Bin output roller
- 3 Transport roller
- 4 Switchback motor of the duplex unit (M2)
- 5 Upper transport roller
- 6 Lower transport roller
- 7 Transport motor of the duplex unit (M1)
- 8 Feed-back roller
- 9 Transport roller
- 10 Paper take-up roller
- 11 Paper take-up motor (M1) of the lower feed unit

3-5. Electrical components layout

(1) Printer

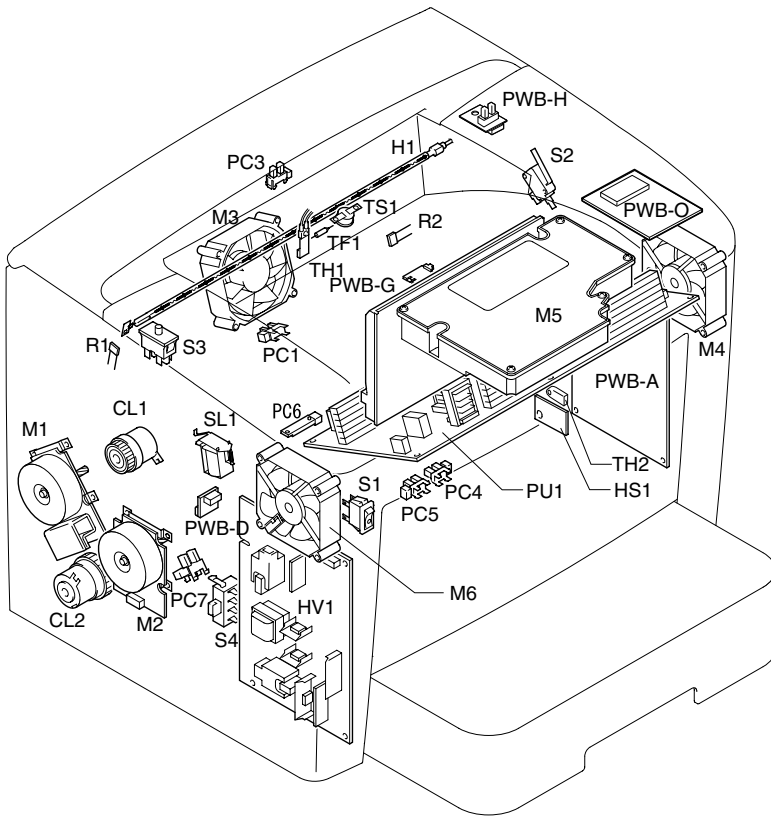

- CL1 Transport roller clutch of the image transfer section
- CL2 Paper take-up clutch for the first paper cassette
- H1 Heater
- HS1 Humidity sensor
- HV1 High voltage unit
- M1 Main motor
- M2 Imaging cartridge drive motor
- M3 Fusing fan motor
- M4 Power supply unit fan motor
- M5 Polygon motor
- M6 Ozone fan motor
- PC1 Paper sensor of the image transfer section
- PC3 Paper output sensor
- PC4 Paper empty sensor for the multipurpose paper tray

PC5	Paper near-empty sensor for the multipurpose paper tray
PC6	Paper empty sensor for the first paper cassette
PC7	Paper near-empty sensor for the first paper cassette
PU1	Power supply board
PWB-A	Main control board
PWB-D	New-imaging-cartridge detection board
PWB-G	Toner empty detection board
PWB-H	Paper full detection board
PWB-O	Control panel board
R1	Resistor 1
R2	Resistor 2
S1	Power switch
S2	Interlock switch 1
S3	Interlock switch 2
S4	Paper size detection switch for the first paper cassette
SL1	Paper take-up solenoid for the multipurpose paper tray
TF1	Thermal fuse
TH1	Thermistor 1
TH2	Thermistor 2
TS1	Thermostat

(2) Lower feed unit (optional)

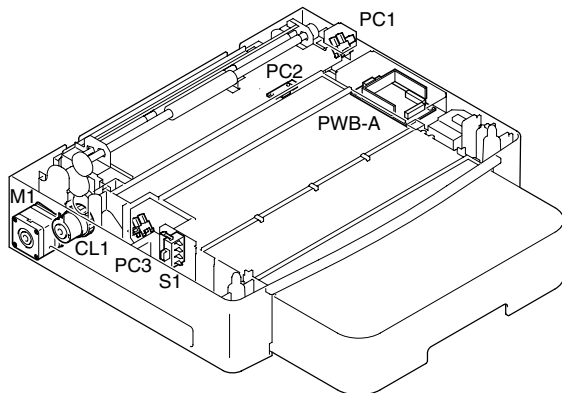

- CL1 Paper take-up clutch
- M1 Paper take-up motor
- PC1 Paper sensor
- PC2 Paper empty sensor
- PC3 Paper near-empty sensor
- PWB-A Control board
- S1 Paper size detection switch

(3) Duplex unit (optional)

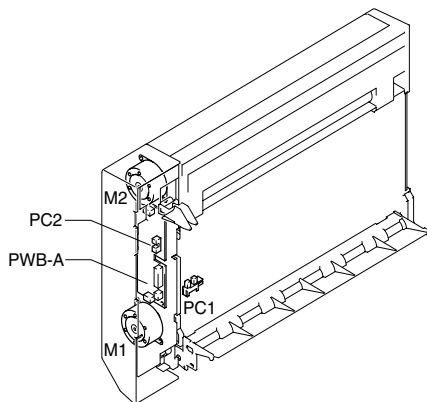

- M1 Transport motor
- M2 Switchback motor
- PC1 Duplex cover switch
- PC2 Duplex unit paper sensor (on PWB-A)
- PWB-A Control board of the duplex unit

(4) 4-bin mailbox (optional)

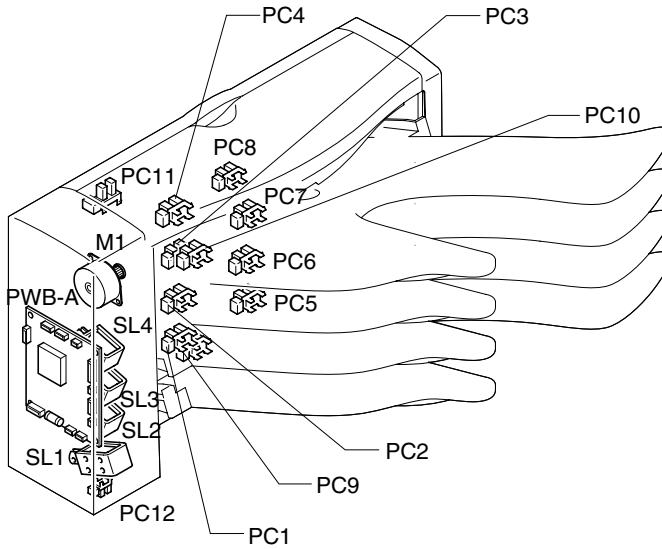

- M1 Transport motor
- PC1~4 Bin empty sensor 1~ 4
- PC5~PC8 Bin full sensor 1~ 4
- PC9 Lower transport sensor
- PC10 Upper transport sensor
- PC11 Cover sensor
- PC12 Set sensor
- PWB-A Control board
- SL1 Entrance guide switching solenoid
- SL2~SL4 Bin entrance switching solenoid

3-6. Electrical components functions

(1) Printer

Symbol	Name	Function
CL1	Transport roller clutch of the image transfer section	Transmits the driving force from the main motor to the transport roller of the image transfer section.
CL2	Paper take-up clutch for the first paper cassette	Transmits the driving force from the main motor to the paper take-up roller of the first paper cassette.
H1	Heater	Heats the heat roller.
HS1	Humidity sensor	Detects the humidity within the machine, and sends that data to the main control board.
HV1	High voltage unit	Steps up the voltage of the direct current (DC) output from the power supply board to a high voltage, and supplies it to the drum-charging section, the image transfer section and the developing section.
M1	Main motor	Provides the driving force for each part of the printer; main drive source.
M2	Imaging cartridge drive motor	Drives the imaging cartridge.
M3	Fusing fan motor	Cools the fusing section and the inside of the machine. In addition, the paper being printed is drawn toward the image transfer unit. (suction effect)
M4	Power supply unit fan motor	Absorbs outside air and cools the power supply section and the print head unit section. In addition, sends ozone, generated within the machine, to the ozone fan motor (M6).
M5	Polygon motor (within the print head unit)	A regular hexahedron polygon mirror rotates at a high speed, causing the laser to irradiate the surface of the PC drum in the main scanning direction.
M6	Ozone fan motor	Expels air from inside the machine to the outside. In addition, the ozone filter attached to the fan removes any ozone generated within the machine.
PC1	Paper sensor of the image transfer section	Detects whether paper has been loaded and whether the paper has been transported.
PC3	Paper output sensor	Detects whether paper has been fed out by the transport roller.
PC4	Paper empty sensor for the multipurpose paper tray	Detects whether there is no paper in the multipurpose paper tray.
PC5	Paper near-empty sensor for the multipurpose paper tray	Detects whether there is almost no paper in the multipurpose paper tray.
PC6	Paper empty sensor for the first paper cassette	Detects whether there is no paper in the first paper cassette.
PC7	Paper near-empty sensor for the first paper cassette	Detects whether there is almost no paper in the first paper cassette.
PU1	Power supply board	Converts the power supply voltage from alternating current (AC) to direct current (DC) and outputs it. The alternating current is supplied by the heater (H1).
PWB-A	Main control board	Controls all printer operations.
PWB-D	New-imaging-cartridge detection board	Detects the record information for the imaging cartridge.
PWB-G	Toner empty detection board	Detects whether the toner in the imaging cartridge is empty.
PWB-H	Paper full detection board	Detects the amount of paper that has been fed into the face-down output tray. PS3 is mounted on board.

Symbol	Name	Function
PWB-O	Control panel board	Operates the printer through the operation keys and indicates the status of the printer through the indicator and message display.
R1	Resistors	Prevents poor image transfer, and prevents noise from being generated.
R2		
S1	Power switch	Switches on and off the power.
S2	Interlock switch 1	Detects whether the top rear cover is open or closed, and interrupts the DC 24 V direct current (DC) output power if the cover is open.
S3	Interlock switch 2	Interrupts the alternating current (AC) output power to the heater (H1) if the top rear cover is open.
S4	Paper size detection switch for the first paper cassette	Detects the size of the paper loaded into the first paper cassette.
SL1	Paper take-up solenoid for the multipurpose paper tray	Transmits the driving force from the main motor to the paper take-up roller for the multipurpose paper tray.
TF1	Thermal fuse	Interrupts the electric conduction to the heater (H1) when there is an abnormally high temperature in the fusing section.
TH1	Thermistor 1	Detects the temperature on the surface of the heat roller, and sends that data to the main control board.
TH2	Thermistor 2	Detects the atmospheric temperature within the machine, and changes developing bias DC voltage to match
TS1	Thermostat	Controls the temperature of the heat roller surface. If the temperature exceeds 450 °C, then the circuit conducting electricity to the heater (H1), the DC 24 V circuit and the relays are forcibly cut.

(2) Lower feed unit (optional)

Symbol	Name	Function
CL1	Paper take-up clutch	Transmits the driving force from the paper take-up motor to the paper take-up roller of the lower feed unit.
M1	Paper take-up motor	Drives the paper take-up roller and the transport roller.
PC1	Paper sensor	Detects whether paper has been loaded and whether the paper has been transported.
PC2	Paper empty sensor	Detects whether there is no paper in the cassette.
PC3	Paper near-empty sensor	Detects whether there is almost no paper in the cassette.
PWB-A	Control board	Receives control signals and power from the printer's main control board PWB-A, and sends them to the electrical components within the lower feed unit.
S1	Paper size detection switch	Detects the size of the paper loaded into the cassette.

(3) Duplex unit (optional)

Symbol	Name	Function
M1	Transport motor	Drives the feed-back roller and the transport roller.
M2	Switchback motor	Rotates the paper output roller in the printer's fusing unit in both directions, and feeds the paper back into the duplex unit.
PC1	Duplex cover switch	Detects whether the duplex cover is open or closed, and stops the functions of the duplex unit if its cover is open.
PC2	Duplex unit paper sensor	Detects whether paper has been fed into the duplex unit.
PWB-A	Control board of the duplex unit	Receives control signals and power from the printer's main control board PWB-A, and sends them to the electrical components within the duplex unit.

(4) 4-bin mailbox (optional)

Symbol	Name	Function
M1	Transport motor	Drives the bin output roller and the transport roller of the 4-bin mailbox.
PC1	Bin empty sensor 1	Detects whether paper has been fed into the bin.
PC2	Bin empty sensor 2	
PC3	Bin empty sensor 3	
PC4	Bin empty sensor 4	
PC5	Bin full sensor 1	Detects whether the paper fed into the mailbin has reached the maximum capacity.
PC6	Bin full sensor 2	
PC7	Bin full sensor 3	
PC8	Bin full sensor 4	
PC9	Lower transport sensor	Detects whether paper has been fed from the printer.
PC10	Upper transport sensor	Detects whether paper has been transported to a mailbin.
PC11	Cover sensor	Detects whether the 4-bin mailbox cover is open or closed, and stops the functions of the 4-bin mailbox if its cover is open.
PC12	Set sensor	Detects whether the 4-bin mailbox unit is open or closed, and stops the functions of the 4-bin mailbox if it is slid open.
PWB-A	Control board of the 4-bin mailbox	Receives control signals and power from the printer's main control board PWB-A, and sends them to the electrical components within the 4-bin mailbox.
SL1	Entrance guide switching solenoid	Moves the entrance guide, and directs the paper fed from the printer into the 4-bin mailbox.
SL2	Bin entrance switching solenoid 1	Moves the bin entrance switch, and directs the transported paper to each mailbin.
SL3	Bin entrance switching solenoid 2	
SL4	Bin entrance switching solenoid 3	

(5) PWB-A (main control board)

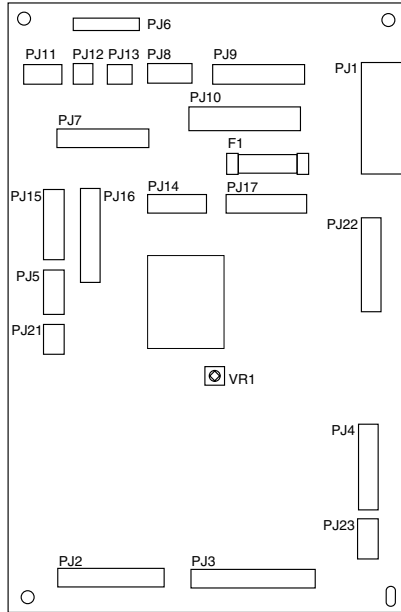

- F1 Fuse (rated: 15 A, 250 V)
- PJ1 To the printer controller
- PJ2 To the fusing section and the transport section
- PJ3 To the relay section for the multipurpose paper tray
- PJ4 To the lower feed unit
- PJ5 To the new-imaging-cartridge detection board
- PJ6 To the laser diode
- PJ7 To the high voltage unit
- PJ8 To the polygon motor
- PJ9 To the main motor and the imaging cartridge drive motor
- PJ10 To power supply section 1
- PJ11 To power supply section 2
- PJ12 To power supply section 3
- PJ13 To the ozone fan motor
- PJ14 To the left side of the printer
- PJ15 To the paper size detection board for the multipurpose paper tray
- PJ16 To the duplex unit
- PJ17 To the 4-bin mailbox
- PJ21 To the paper full detection board
- PJ22 To the control panel board
- PJ23 To the humidity sensor
- VR1 Dial for adjusting the image registration margin (refer to chapter 6.)

(6) PWB-D (new-imaging-cartridge detection board)

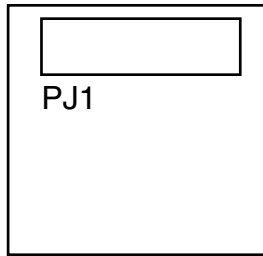

PJ1 To the main control board

(7) PU1 (power supply board)

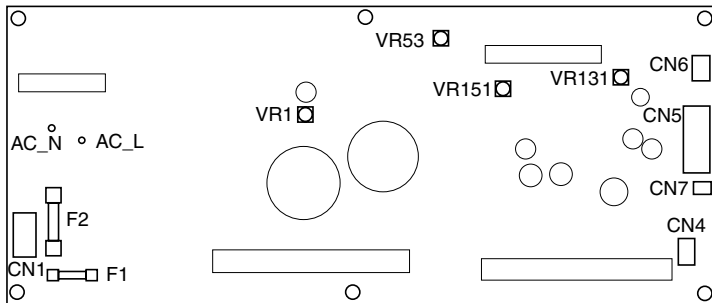

- AC_L To the interlock switch 1 section primary
- AC_N To the interlock switch 1 section primary
- CN1 To the power switch section
- CN4 To the interlock switch 1 section secondary
- CN5 To the main control board
- CN6 To the main control board
- CN7 To the main control board
- F1 Fuse (rated: 10 A, 125 V)
- F2 Fuse (rated: 15 A, 250 V)
- VR1 Factory adjustments (do not adjust.)
- VR131 Factory adjustments (do not adjust.)
- VR151 Factory adjustments (do not adjust.)
- VR53 Factory adjustments (do not adjust.)

(8) HV1 (high voltage unit)

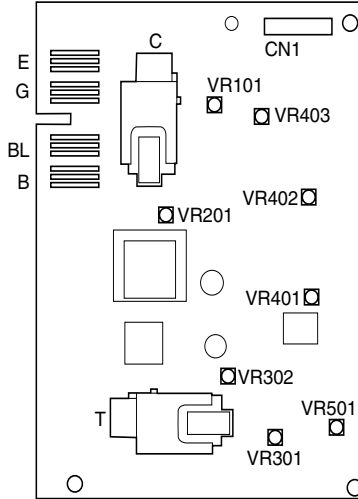

- B To the bias and discharge seal
- BL To the paper take-up roller, blade 1 and blade 2
- C(PJ1-CHV) To the drum-charging section
- CN1 To the main control board
- E To the discharge needle
- G To the grid mesh
- T(PJ1-THV) To the image transfer section
- VR101 Factory adjustments (do not adjust.)
- VR201 Factory adjustments (do not adjust.)
- VR301 Factory adjustments (do not adjust.)
- VR302 Factory adjustments (do not adjust.)
- VR401 Factory adjustments (do not adjust.)
- VR402 Factory adjustments (do not adjust.)
- VR403 Factory adjustments (do not adjust.)
- VR501 Factory adjustments (do not adjust.)

(9) PWB-G (toner-empty detection board)

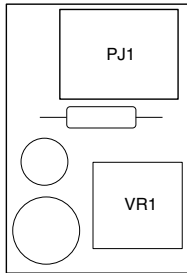

PJ1 To the main control board

VR1 Dial for factory adjustments (do not adjust.)

(10) PWB-H (paper full detection board)

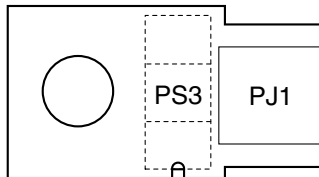

PJ1 To the main control board

PS3 Paper full detection sensor

(11) PWB-O (control panel board)

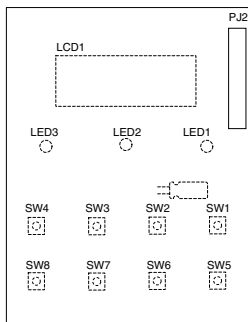

LCD1 Message display

LED1 to LED3 Message indicators

P.I.2 To the main control board(printer)

SW1 to SW8 Control keys

(12) PWB-A (control board of the lower feed unit)

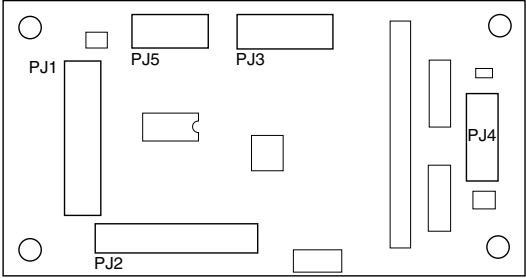

- PJ1 To the main control board
- PJ2 To the unit below
- PJ3 To the paper near-empty sensor and the paper size detection switch
- PJ4 To the paper jam detection sensor and the paper empty sensor
- PJ5 To the paper take-up motor and the paper take-up clutch

(13) PWB-A (DUP) (control board of the duplex unit)

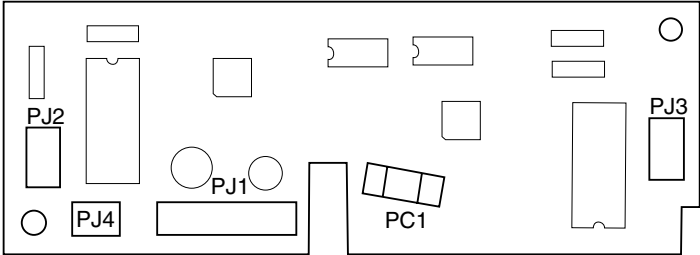

- PC1 To the duplex unit paper sensor
- PJ1 To the main control board
- PJ2 To the transport motor
- PJ3 To the switchback motor
- PJ4 To the duplex cover switch

(14) PWB-A (control board of the 4-bin mailbox)

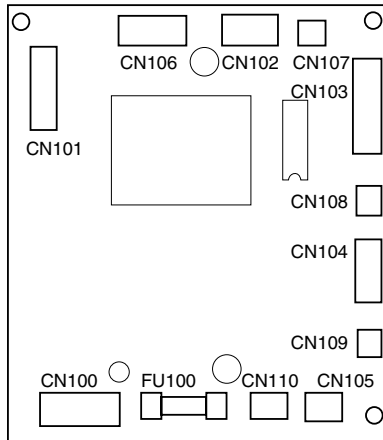

- CN101 To the cover sensor, bin empty sensor 4, and bin full sensor 4
- CN100 To the main control board
- CN102 To bin empty sensor 3 and bin full sensor 3
- CN103 To the upper transport sensor, bin empty sensor 2, and bin full sensor 2
- CN104 To bin empty sensor 1 and bin full sensor 1
- CN105 To the lower transport sensor
- CN106 To the transport motor
- CN107 To bin entrance switching solenoid 3
- CN108 To bin entrance switching solenoid 2
- CN109 To bin entrance switching solenoid 1
- CN110 To the entrance guide switching solenoid
- FU100 Fuse (rated: 1 A, 125 V)

3-7. Video interface

(1) Overview

- The video interface consists of 12 signal wires and the power supply source, as shown below.
- The signal wires include those for image data signals for transmitting images, synchronous signals, signals for observing the status of the power supply, serial transmission signals for obtaining a detailed status of the printer, and reset signals.

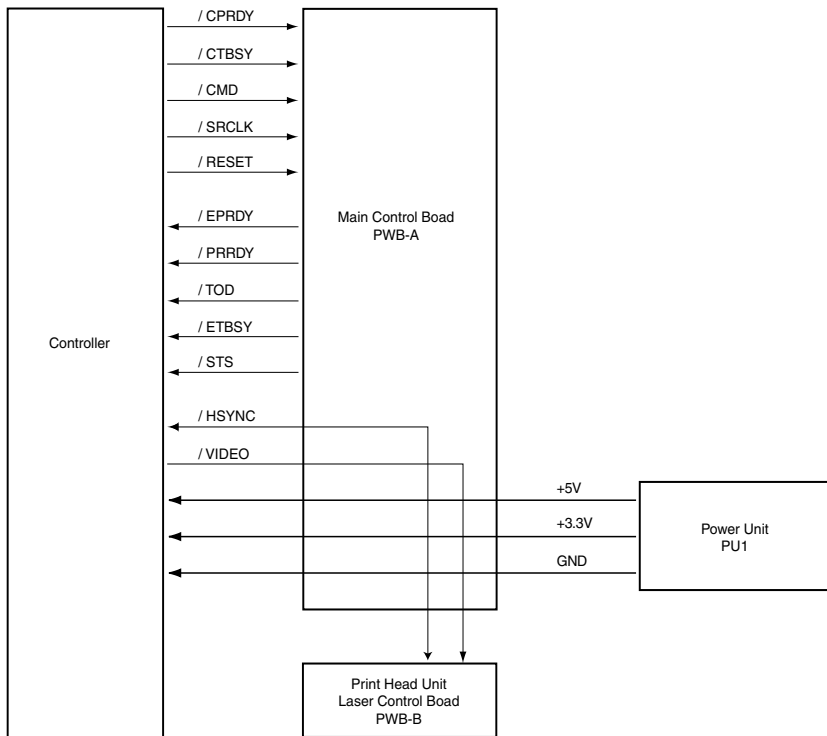

(2) Signal descriptions

There are 12 interface signals, which are divided into 5 categories according to their function.

No.	Signal Name	Code	Function	Category
1	/Controller power ready	/CPRDY	This signal indicates that the controller is ready to send signals to and receive them from the main control board (PWB-A).	Signals for activating the video interface.
2	/Engine power ready	/EPRDY	This signal indicates that the main control board (PWB-A) is ready to send signals to and receive them from the controller.	
3	/Printer ready	/PRRDY	This signal indicates that the printer is ready to print.	Signals that indicate the printer status.
4	/Top of data	/TOD	This is the synchronous signal of the vertical scanning direction (sub-scanning direction) for beginning printing of one page.	Signals for printing images.
5	/Horizontal synchronous	/HSYNC	This is the synchronous signal of the horizontal scanning direction (main scanning direction) for beginning printing of each line.	
6	/Video	/VIDEO	This is the image data signal.	
7	/Controller status busy	/CTBSY	This signal indicates that the controller is sending commands to the main control board (PWB-A).	Signals for serial transmission between the controller and the main control board.
8	/Engine status busy	/ETBSY	This signal indicates that the main control board (PWB-A) is using the /STS signal, and sending the status to the controller.	
9	/Command	/CMD	This signal is used when transmitting 8-bit serial information (commands) to the main control board (PWB-A).	
10	/Status	/STS	This signal is used when the main control board (PWB-A) sends 8-bit serial information (commands) to the controller.	
11	/Serial clock	/SRCLK	This synchronous clock signal is used when the controller sends commands to the main control board (PWB-A), and when the main control board (PWB-A) sends the status to the controller.	
12	/Reset	/RESET	This signal resets the printer hardware.	

3-8. Timing chart

(1) Pre-process sequence

- The processing devices around the PC drum are started up, and the surface of the PC drum is charged with an exposable uniform electric potential.
- When the pre-process sequence is finished, the operation continues with the print (print interval) sequence.

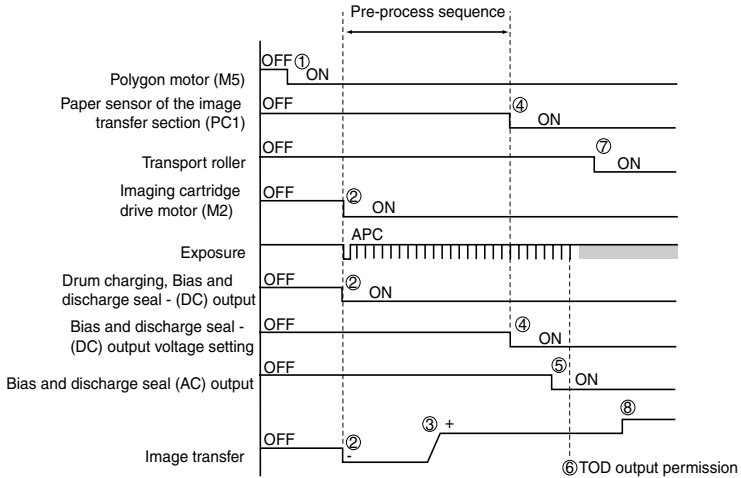

Execution condition: print ON

Start condition: When the process start timing is reached when receiving a print

- 1: Polygon motor ON
- 2: Imaging cartridge drive motor ON, charge, image transfer, grid, discharge; Remote of sheet and discharge needle ON
- 3: Image transfer voltage output
- 4: Developing bias DC remote ON, according to the detected temperature
- 5: Developing bias AC remote ON
- 6: TOD output permitted
- 7: Transport roller ON
- 8: Switch the image transfer current

(2) Print (print interval) sequence

- In order to suppress image quality problems from occurring, the process control is switched when printing and during the print interval.

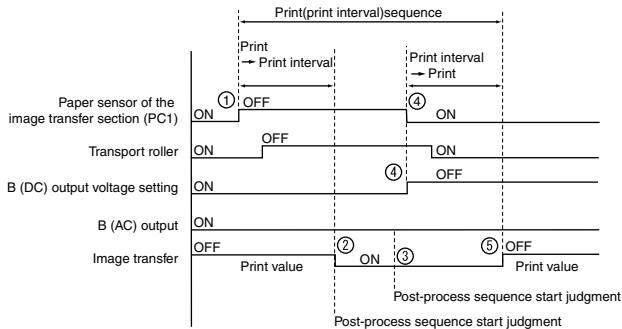

- 1: Begin mode switching from print to print interval
- 2: Image transfer current (print interval) ON
- 3: Post-process sequence shift judgment
- 3: Change developing bias DC voltage to match <thermistor 2> and <image density setting>
- 4: Change image transfer current to match paper size, media and print area

(3) Post-process sequence

- Before stopping the processing devices around the PC drum, the PC drum and image transfer roller is cleaned.
- The processing devices around the PC drum are stopped, and the print operation is finished.

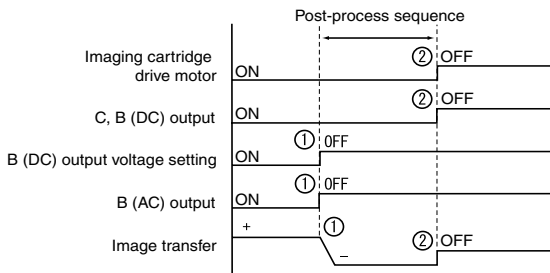

Condition for starting post-process: When the fed paper has passed through all of the image transfer section, and when a paper feed cancel request has been received

Condition for deferring post-process: When the first sheet of paper is waiting to be fed after the process has started

- 1: Image transfer (-) output, developing bias DC remote OFF, and developing bias AC remote OFF
- 2: Imaging cartridge drive motor OFF, Charge, image transfer, grid, discharge; Remote of sheet and discharge needle OFF

4. MECHANICAL/ELECTRICAL

4-1. Paper path

(1) Standard configuration

- Paper can be fed into the printer either from the multipurpose tray (paper capacity: 200 sheets) or the universal paper cassette unit (paper capacity: 500 sheets).
- The paper fed by the paper take-up roller is transported to the transport roller of the image transfer section → the image transfer roller → the fusing roller → the paper output roller, then finally fed out into the face-down output tray.

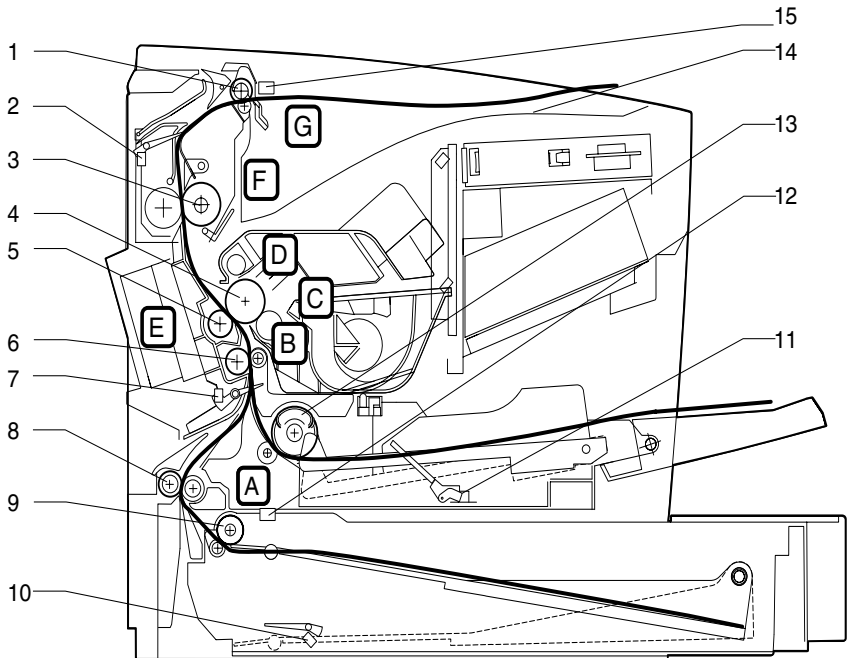

- | | |
|--------------------------|--|
| A Paper take-up section | 1 Paper output roller |
| B Developing section | 2 Paper output sensor (PC3) |
| C Exposure section | 3 Heat roller |
| D Drum-charging section | 4 PC Drum |
| E Image transfer section | 5 Image transfer roller |
| F Fusing section | 6 Transport roller (image transfer section) |
| G Paper exit section | 7 Paper sensor of the image transfer section (PC1) |
| | 8 Transport roller (first paper cassette) |
| | 9 Paper take-up roller for the first paper cassette |
| | 10 Paper near-empty sensor for the first paper cassette (PC7) |
| | 11 Paper near-empty sensor for the multipurpose paper tray (PC5) |

(continued from previous page)

- 12 Paper empty sensor for the first paper cassette (PC6)
- 13 Paper take-up roller for the multipurpose paper tray
- 14 Face-down output tray
- 15 Paper full detection board (PWB-H) (PS3 is mounted on board)

(2) With options installed

- By installing up to three optional lower feeder units (paper capacity: 500 sheets), the printer can be expanded to have a maximum of 5 paper sources.
- Double-sided printing is possible if the optional duplex unit is installed.
- The printouts can be sorted by installing the optional 4-bin mailbox.
- When double-sided printing is selected, the paper is transported to the transport roller of the image transfer section → the image transfer roller → the fusing roller → the paper output roller → the upper transport roller of the duplex unit → the lower transport roller of the duplex unit → the feed-back roller of the duplex unit → the transport roller of the image transfer section → the image transfer roller → the fusing roller → the paper output roller, then finally fed out into the face-down output tray.
- If sorted printing is selected, the paper is transported to the transport roller of the image transfer section → the image transfer roller → the fusing roller → the lower transport roller of the 4-bin mailbox → the upper transport roller of the 4-bin mailbox → the paper output roller, then finally fed out into the mailbin trays.

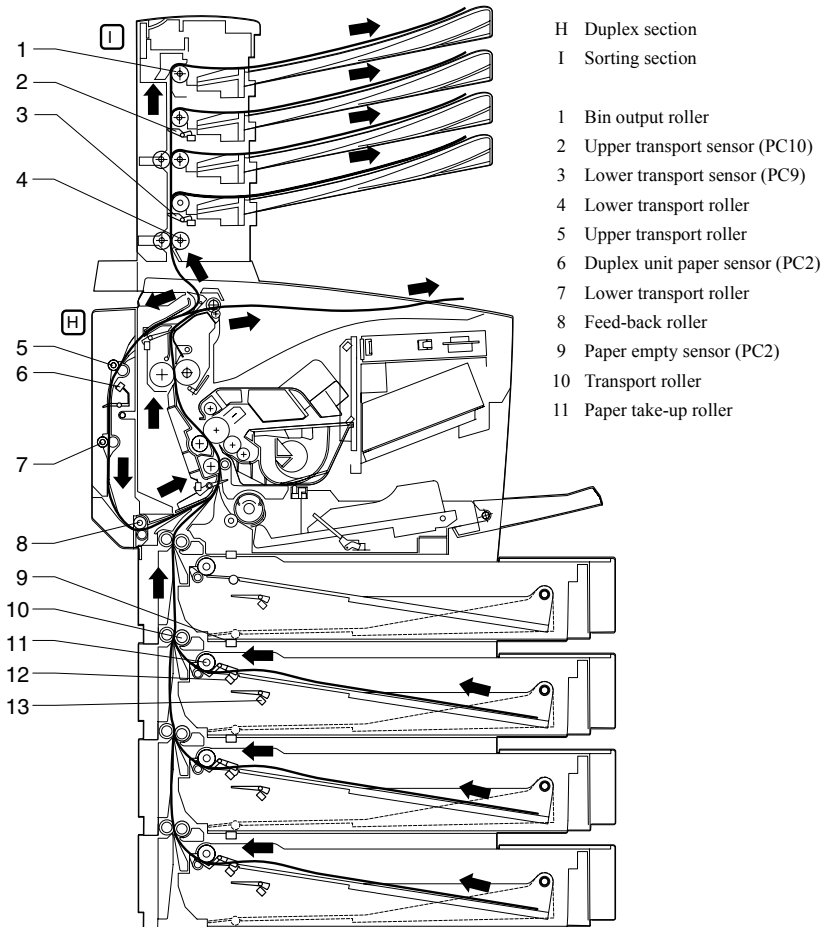

4-2. Paper take-up section

(1) Multipurpose paper tray: paper take-up mechanisms & process

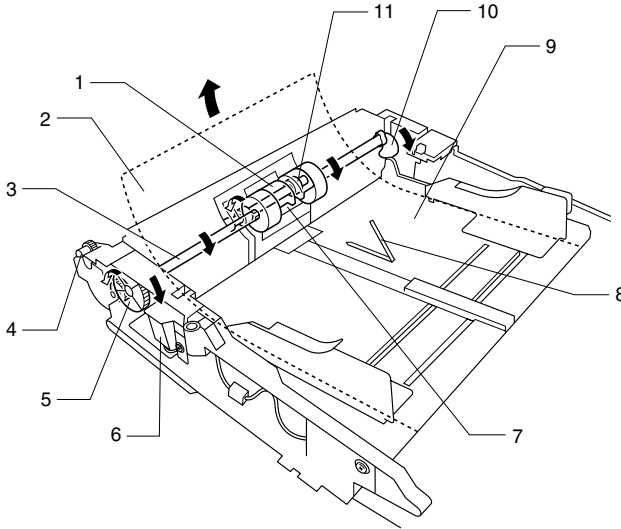

- | | |
|------------------------------------|---|
| 1 Paper take-up roller | 7 Paper-separating pad |
| 2 Paper | 8 Paper empty/paper near-empty actuator |
| 3 Paper take-up roller drive shaft | 9 Paper-lifting plate |
| 4 Unit drive gear | 10 Cam |
| 5 Paper take-up roller drive gear | 11 Transport roller |
| 6 Paper take-up solenoid (SL1) | |

1. When the paper take-up solenoid (SL1) is activated, the solenoid locking catch that secures the paper take-up roller drive gear, attached to the paper take-up roller shaft, in a fixed position is released by the cam of the paper take-up roller drive gear.
2. The paper take-up roller drive gear is rotated by the spring attached to it, and linked to the unit drive gear.

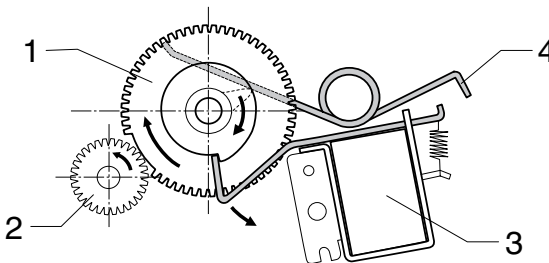

- | | |
|-----------------------------------|-------------------|
| 1 Paper take-up roller drive gear | 3 Unit drive gear |
| 2 Paper take-up solenoid (SL1) | 4 Spring |

- The driving force from the main motor (M1) is transmitted from the unit drive gear to rotate the paper take-up roller shaft.

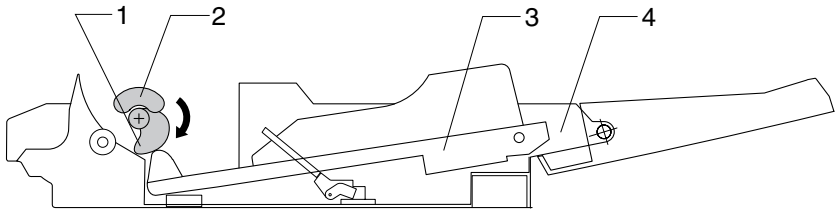

- | | |
|------------------------|---------------------------|
| 1 Cam | 3 Paper-lifting plate |
| 2 Paper take-up roller | 4 Multipurpose paper tray |

- The cam attached to the paper take-up roller shaft rotates, allowing the paper-lifting plate to be raised by the spring.

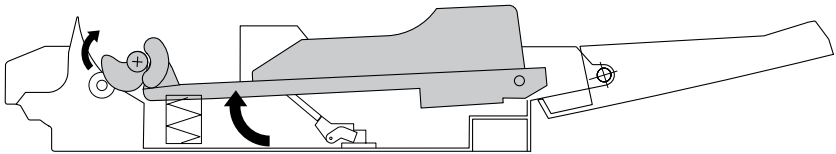

- The paper take-up roller, attached to the paper take-up roller shaft, rotates once, the pick-up surface of the paper take-up roller contacts the paper, and then the paper is fed to the transport roller.
A fixed separating pad is used to separate the paper, preventing other sheets of paper from being fed together with the first.
- The transport roller attached to the paper take-up roller shaft feeds the paper into the printer.
- When the paper take-up roller drive gear is rotated once, the driving force from the main motor is released by the missing teeth, causing the rotation to stop.
- The locking catch of the paper take-up solenoid (SL1) secures the paper take-up roller drive gear in place.

(2) Multipurpose paper tray: paper feed retry control

- If the paper feed operation began, but the paper take-up roller was not able to pick up the paper, instead of concluding that a paper jam occurred, the paper feed operation is performed again (paper feed retry function).
- If the second attempt of the paper feed operation (first paper feed retry) fails, the paper feed operation is performed one more time.
- If no paper was fed and the paper sensor of the image transfer section (PC1) could not detect the leading edge of the paper during the third attempt of the paper feed operation (second paper feed retry), the printer concludes that a paper jam occurred.
- The paper feed operation is attempted three times, including the initial attempt.

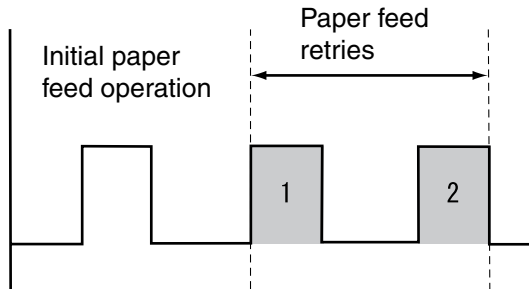

(3) Multipurpose paper tray: paper empty detection mechanism

- The multipurpose paper tray is equipped with a paper empty sensor (PC4), which monitors the amount of paper remaining in the multipurpose tray.
- If paper is present in the tray, the actuator is pressed down by the paper. (The actuator is attached to the same shaft as the paper near-empty sensor.)

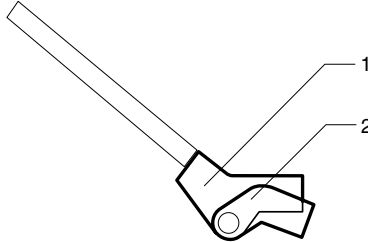

1 Paper empty actuator (toward the back) 2 Paper near-empty actuator (toward the front)

- Since the actuator does not interrupt the sensor light, the sensor light passes through, enabling the sensor to determine that paper is present in the multipurpose paper tray.
- If there is no paper, the actuator is raised by the spring, blocking the sensor light. If the sensor light is interrupted for 0.5 seconds or more, the sensor determines that there is no paper.

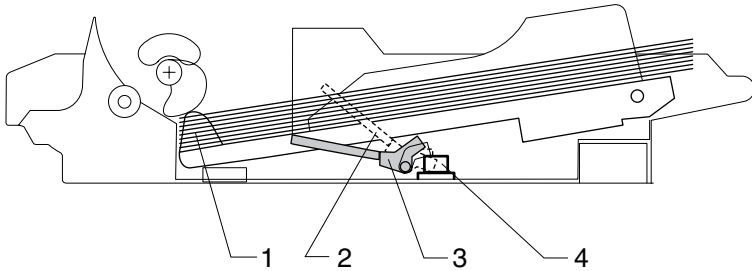

1 Paper (when full)
 2 Actuator (paper empty status)
 3 Actuator (paper full status)
 4 Paper empty sensor (PC4)

(4) Multipurpose paper tray: paper near-empty detection mechanism

- The multipurpose paper tray is equipped with a paper near-empty sensor (PC5), which monitors the amount of paper remaining while printing.
- If there is a sufficient amount of paper remaining, the actuator is pressed down by the paper. (The actuator is the same as that for the paper empty sensor.)
- Since the actuator does not interrupt the sensor light, the sensor light passes through, enabling the sensor to determine that a sufficient amount of paper remains.
- If there is not much paper left, the actuator is raised by the spring, blocking the sensor light. When the sensor light is interrupted, the sensor determines that there is little paper remaining (near-empty).
- The sensor detects a near-empty state when approximately 50 sheets of paper (normal paper, 64 g/m²) remain. However, the amount of paper detected fluctuates depending on the weight of the paper.

Note

Since the paper near-empty condition is only monitored while printing, the actuator blocking the sensor light during stand-by is not considered a paper near-empty condition.

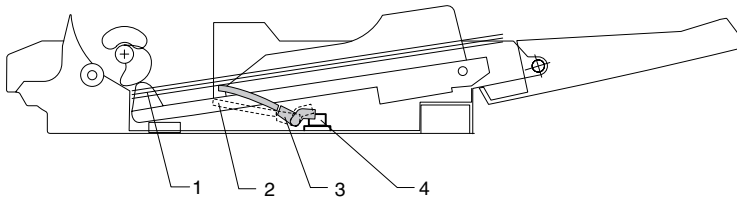

- 1 Paper (when near-empty)
- 2 Actuator (paper full status)
- 3 Actuator (paper near-empty status)
- 4 Paper near-empty sensor (PC5)

(5) Universal paper cassette (first through fourth paper cassettes): paper take-up mechanism

- When the paper cassette is inserted into the printer, the lock for the paper-lifting plate is released, and the paper-lifting plate is raised by the spring.
- When the paper take-up clutch for the first paper cassette is activated, the driving force from the main motor is transmitted to the drive gear attached to the paper take-up roller shaft, and the paper take-up roller shaft is rotated.
- The paper take-up roller attached to the paper take-up roller shaft is rotated, feeding the paper into the printer. A paper-separating roller is used to separate the paper, preventing other sheets of paper from being fed together with the first.
- When the paper cassette is pulled out of the printer, the paper-lifting plate is lowered by the cassette-mounting rail, then locked into place.

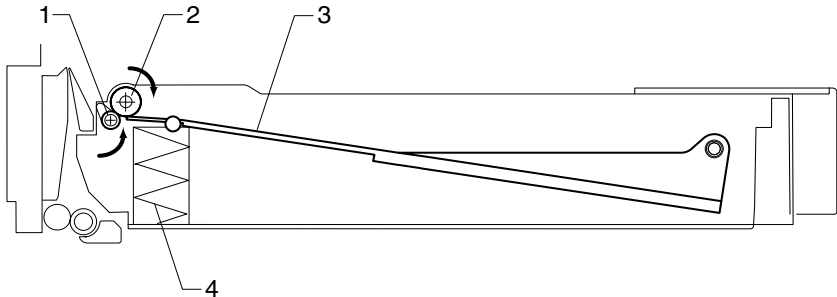

- 1 Paper-separating roller
- 2 Paper take-up roller
- 3 Paper-lifting plate
- 4 Spring

(6) Universal paper cassette (first paper cassette): paper feed retry control

- If the paper feed operation has already begun, but the paper take-up roller was not able to pick up the paper, instead of concluding that a paper misfeed has occurred, the paper feed operation is performed again (paper feed retry function).
- If no paper was fed and the paper sensor of the image transfer section (PC1) could not detect the leading edge of the paper during the second attempt of the paper feed operation (paper feed retry), the printer concludes that a paper misfeed has occurred.
- The paper feed operation is attempted twice, including the initial attempt.

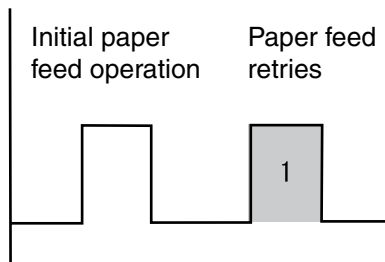

(7) Lower feed unit (second through fourth paper cassettes): paper feed retry control

- If the paper feed operation has already begun, but the paper take-up roller was not able to pick up the paper, instead of concluding that a paper misfeed has occurred, the paper feed operation is performed again (paper feed retry function).
- If the second attempt of the paper feed operation (first paper feed retry) fails, the paper feed operation is performed one more time.
- If no paper was fed and the paper sensor of the image transfer section (PC1) could not detect the leading edge of the paper during the third attempt of the paper feed operation (second paper feed retry), the printer concludes that a paper misfeed has occurred.
- The paper feed operation is attempted three times, including the initial attempt.

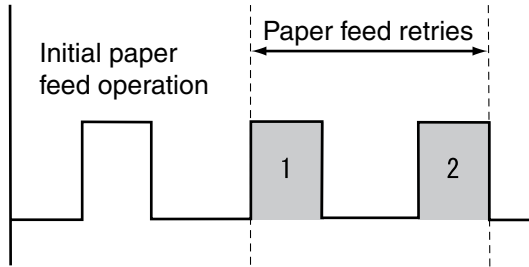

(8) Universal paper cassette (first paper cassette): paper empty detection mechanism

- The paper empty sensor for the first paper cassette (PC6) is installed below the multipurpose tray to monitor the amount of paper remaining in the universal paper cassette (first paper cassette).
- If paper is present in the cassette, light from the emitter of the paper empty sensor for the first paper cassette (PC6) reflects off the paper. If the sensor receiver picks up the reflected light, the sensor determines that paper is present in the cassette.

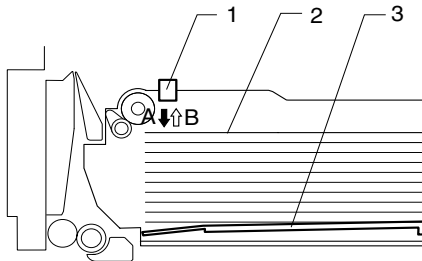

- | | |
|----------------------------------|---|
| A Sensor light (emitted light) | 1 Paper empty sensor for the first paper cassette (PC6) |
| B Sensor light (reflected light) | 2 Paper |
| | 3 Paper-lifting plate (paper full status) |

- If there is no paper in the cassette, the light from the paper empty sensor of the first paper cassette is absorbed by the light-absorbing material affixed to the bottom of the cassette, resulting in sensor not detecting reflected light. If the sensor light is interrupted for 0.5 seconds or more, the sensor determines that there is no paper.

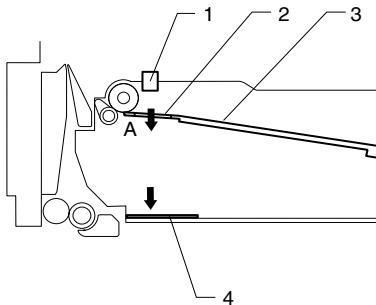

- | |
|---|
| 1 Paper empty sensor for the first paper cassette (PC6) |
| 2 Sensor light pass-through window |
| 3 Paper-lifting plate (paper empty status) |
| 4 Light-absorbing material |

(9) Universal paper cassette (second through fourth paper cassettes): paper empty detection mechanism

- The paper empty detection mechanism for monitoring the amount of paper remaining in the second through fourth optional paper cassettes is the same as that for the first paper cassette.
- The difference from the first paper cassette is the mounting location of the paper empty sensor (PC2). In the paper empty detection mechanism for the first paper cassette, the paper empty sensor is mounted below the multipurpose tray; however, in the other paper cassettes, it is mounted on the top of the expansion paper cassette unit.

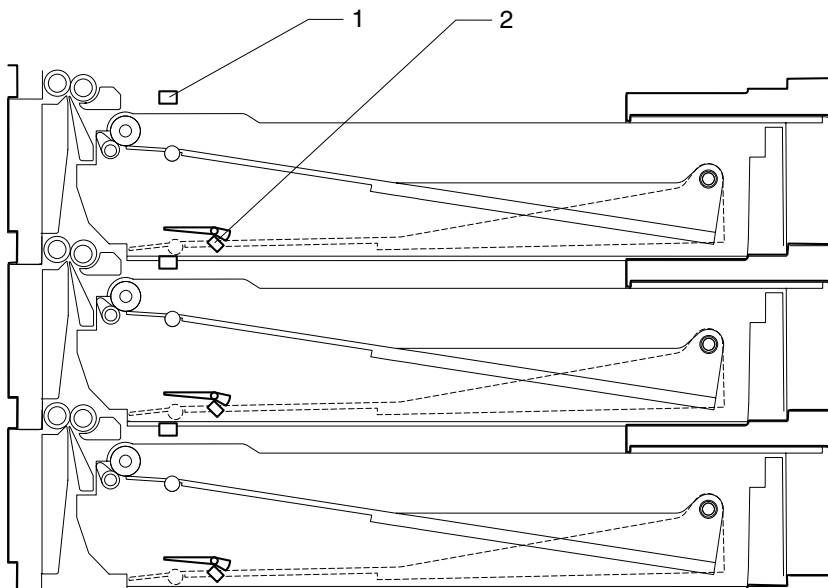

- 1 Paper empty sensor (PC2))
- 2 Paper near-empty sensor (PC3)

(10) Universal paper cassette (first through fourth paper cassettes): paper near-empty detection mechanism

- A paper near-empty sensor (PC7) (see page 48, item #10) is installed in the mounting section of the first paper cassette in order to monitor the amount of paper remaining in the first paper cassette. In addition, the paper near-empty sensor (PC3) is installed in the top of the lower feed unit to monitor the amount of paper remaining in the second through fourth expansion cassettes.
- When paper is present in the cassette, the paper-lifting plate is lowered so that the actuator is not raised. Since the actuator does not interrupt the sensor light, the sensor light passes through, enabling the sensor to determine that paper is present.
- If there is not much paper left, the paper-lifting plate is raised, lifting the actuator, which blocks the sensor light. If the sensor light is interrupted for 0.5 seconds or more, the sensor determines that there is little paper remaining.

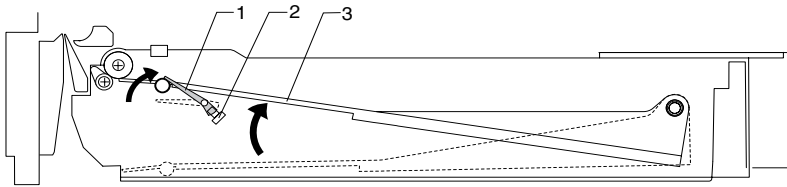

- 1 Paper near-empty sensor actuator
- 2 Paper empty sensor
- 3 Paper-lifting plate

Note

When the paper empty sensor detects an empty status one or more times while the actuator is not blocking the sensor for 0.5 seconds or more, it is not considered a near-empty condition.

(11) Universal paper cassette: paper size detection mechanism

- A paper size detection mechanism for the first paper cassette is mounted in the universal paper cassette and the mounting section of the first paper cassette.
The setting of the paper size detection levers on the left side of the universal paper cassette changes according to the installation location of the paper trailing-edge guide, positioned to match the size of the paper loaded.
- When the universal paper cassette is inserted into the printer, the paper size detection levers press the paper size detection switch (S4) depending on the paper size.
- The paper size detection switch (S4) consists of four linked switches. The size of the paper loaded into the cassette is detected based on the combination of ON/OFF settings of the paper size detection switch (S4).
- When the universal paper cassette is pulled out from the printer, all paper size detection levers are set to OFF, and it detects that the universal paper cassette is not installed.

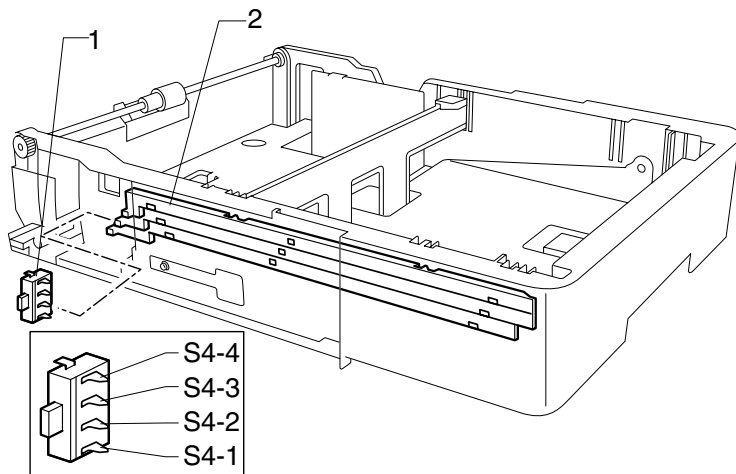

- 1 Paper size detection switch (S4)
- 2 Paper size detection levers

Media sizes	No cassette								G Letter	B4	11X17	Letter	A4C	A3	Legal	B5C
S4-1	OFF	OFF	OFF	OFF	OFF	OFF	OFF	OFF	ON	ON	ON	ON	ON	ON	ON	ON
S4-2	OFF	OFF	OFF	OFF	ON	ON	ON	ON	OFF	OFF	OFF	OFF	ON	ON	ON	ON
S4-3	OFF	OFF	ON	ON	OFF	OFF	ON	ON	OFF	OFF	ON	ON	OFF	OFF	ON	ON
S4-4	OFF	ON	OFF	ON	OFF	ON	OFF	ON	OFF	ON	OFF	ON	OFF	ON	OFF	ON

4-3. Imaging cartridge

(1) Overview

The imaging cartridge integrates the functions for charging, developing, cleaning, toner supply and waste toner storage.

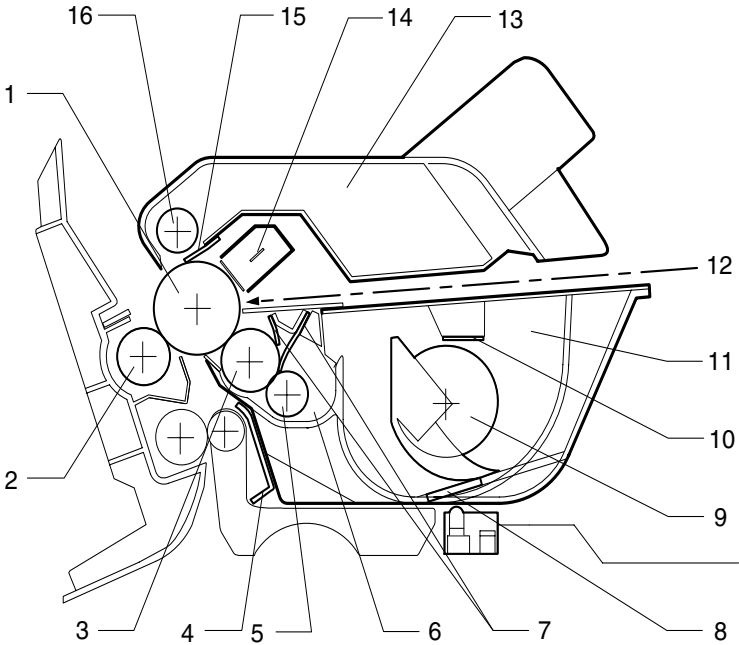

	Name	Function
1	PC drum	A latent image is created on the surface with a laser, developing is performed by the developing roller, and the developed image is transferred to the surface of the paper.
2	Image transfer roller (printer's image transfer section)	Transfers the toner image from the PC drum to the paper.
3	Developing roller	The developing roller is rotated so that toner is transferred to the surface of the PC drum for development.
4	PC drum protective cover	Covers and protects the surface of the PC drum when the imaging cartridge is removed from the printer.
5	Toner supply roller	Transfers toner to the developing roller.
6	Toner buffer section	Stores toner transferred by the toner supply roller.
7	Toner control plate	Uniformly distributes a thin layer of toner on the developing roller. The toner is negatively charged when fed between the toner control plate and the developing roller.
8	LED light pass-through window	Allows LED light from the toner empty sensor to penetrate.
9	Toner-agitating blade	Agitates the toner in the toner hoppers and sends the toner to the buffer section.

	Name	Function
10	Mirror	LED light from the toner empty sensor is reflected when only a small amount of toner remains.
11	Toner hopper section	Stores toner.
12	Laser beam	Path of the laser beam emitted from the print head section.
13	Waste toner collection section	Stores collected waste toner.
14	Charger	Charges the PC drum.
15	Cleaning blade	Scrapes off toner remaining on the PC drum (waste toner) after transferring the image to paper.
16	Waste toner collection blade	Collects the waste toner scraped off by the cleaning blade.

(2) Toner empty detection

- The toner near-empty status is detected by the toner empty sensor LED and the photo sensor on the toner empty detection board (PWB-G).
- The sensor light is emitted from the toner empty sensor LED onto the mirror in the toner hopper.

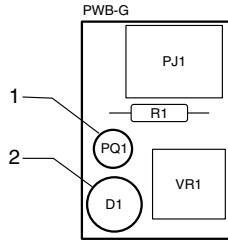

1 Toner empty sensor (receiver; PQ1)

2 Toner empty sensor (emitter; D1)

- When there is a sufficient amount of toner remaining in the hopper, light from the LED is blocked by the toner and is not picked up by the photo sensor receiver, enabling the photo sensor to determine that toner is present.
- When only a small amount of toner remains in the hopper, the LED light passes through and reflects off the mirror. The reflected LED light is picked up by the photo sensor.

When the amount of toner is sufficient

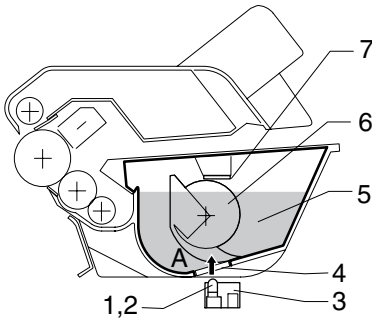

When the toner is nearly empty

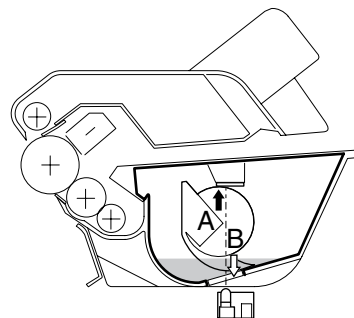

- 1 Toner empty sensor (emitter; D1)
- 2 Toner empty sensor (receiver; PQ1)
- 3 Toner empty detection board (PWB-G)
- 4 Sensor light pass-through window
- 5 Toner
- 6 Toner-agitating blade
- 7 Mirror

- A Sensor light (emitted light)
- B Sensor light (reflected light)

- The length of time that the photo sensor picks up the light is used to calculate the toner empty status of the hopper.
- The state in which the sensor detection voltage continues to be below specification during a period of time exceeding specification and an agitation cycle is detected is considered a toner near-empty condition.

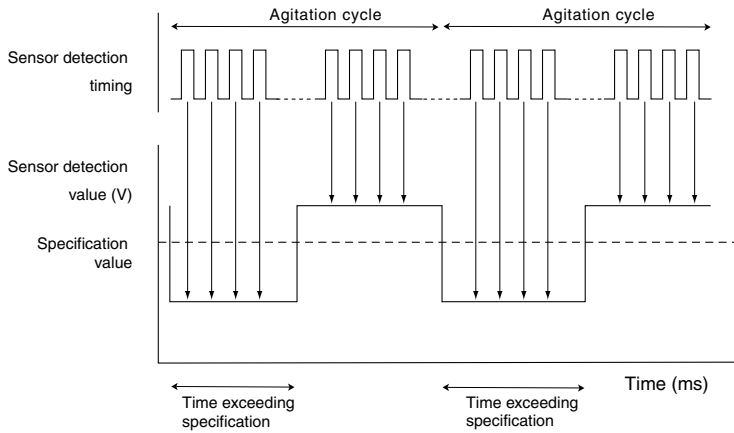

- A toner empty status is considered to have been reached as soon as one of the following conditions occurs after the toner near-empty status has been detected.
 - 1 When the equivalent of 1,200 sheets have been printed (A4 size, black/white ratio=5%) after the toner near-empty status has been detected.
 - 2 When the equivalent of 800 sheets have been printed (1 print/job) after the toner near-empty status has been detected.

4-4. Drum charging

- The surface of the PC drum is charged with static electricity before laser exposure.
- A needle electrode/scorotron system is used as the charging method by the charger.
- The needle electrode is directed at the surface of the PC drum and the DC (-) corona is discharged.
- The surface of the PC drum is evenly charged because of the grid voltage DC (-) applied by the grid mesh.

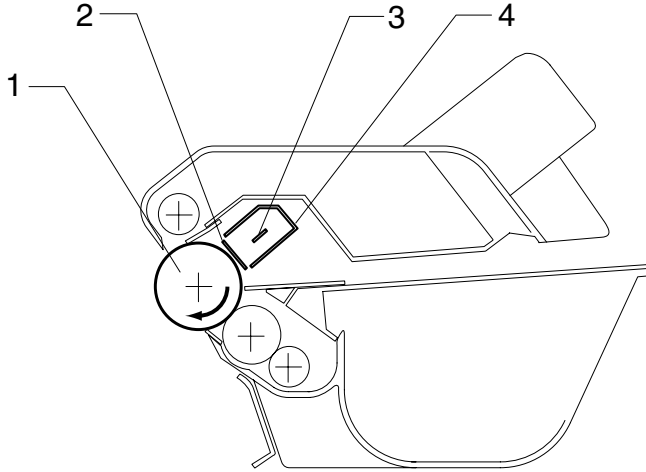

- 1 PC Drum
- 2 Grid mesh
- 3 Needle electrode
- 4 Charger

4-5. Laser exposure

- A latent electrostatic image is created on the PC drum by the laser beam emitted from the print head unit.
- The laser beam is emitted from the laser aperture of the print head unit into the mirror unit.
- The laser beam that penetrated the mirror unit is emitted into the imaging cartridge through the laser aperture of the mirror unit via two mirrors.
- The laser beam that penetrated the imaging cartridge is radiated onto the surface of the PC drum.

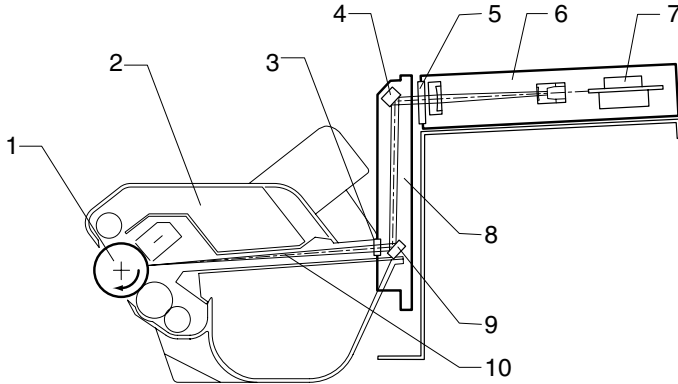

Print head unit (Top view)

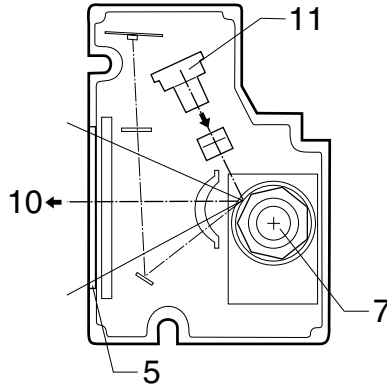

- | | |
|---|----------------------|
| 1 PC Drum | 7 Polygon motor (M5) |
| 2 Imaging cartridge | 8 Mirror unit |
| 3 Laser aperture of the mirror unit | 9 Mirror (lower) |
| 4 Mirror (upper) | 10 Laser beam |
| 5 Laser aperture of the print head unit | 11 Laser diode |
| 6 Print head unit (PH) | |

4-6. Development

Toner is applied to the latent electrostatic image on the PC drum and a toner image (actual image) is formed.

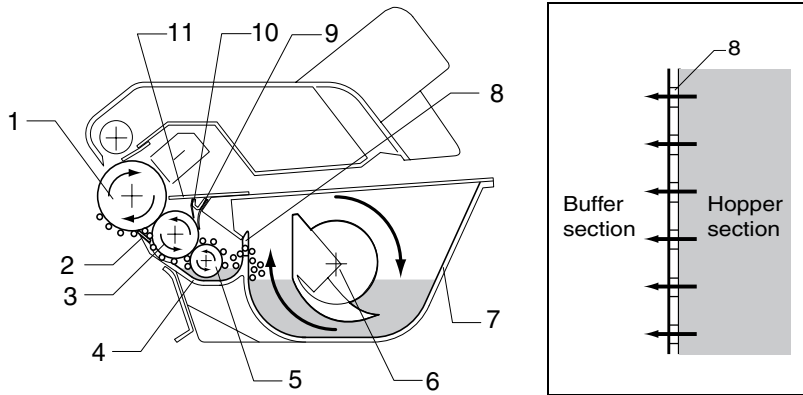

- 1 PC Drum
- 2 Discharge seal
- 3 Developing roller
- 4 Buffer section
- 5 Toner supply roller
- 6 Toner-agitating blade
- 7 Hopper section
- 8 Toner supply outlets
- 9 Blade 1
- 10 Blade 2
- 11 Smoke barrier film

- New toner is filled into the hopper section.
- Toner in the hopper section is fed into the buffer section through the supply outlets due to the rotating action of the toner-agitating blade. There are six toner supply outlets in the barrier wall between the hopper section and the buffer section.

4-7. Image transfer

- Image transfer is the process of transferring to paper the toner image created on the PC drum during the development process.
- For the image transfer method, roller image transfer is used instead of corona image transfer.
- With the roller image transfer method, very little ozone is generated due to corona discharge. In addition, there is no blurring during image transfer since the paper is always pressed between the PC drum and the image transfer roller.
- During image transfer, since the toner applied to the PC drum is negatively charged, a positive charge is applied to the image transfer roller. Because of the positive charge transferred to the back of the paper, the toner on the PC drum is transferred to the front of the paper.
- While cleaning the PC drum and at the beginning of printing, a negative charge is applied to the image transfer roller so that toner does not adhere to it (the PC drum and the image transfer roller normally contact each other even when not printing), and instead the toner returns to the PC drum.
- The residual electric potential in the paper is dissipated by the discharge needle.

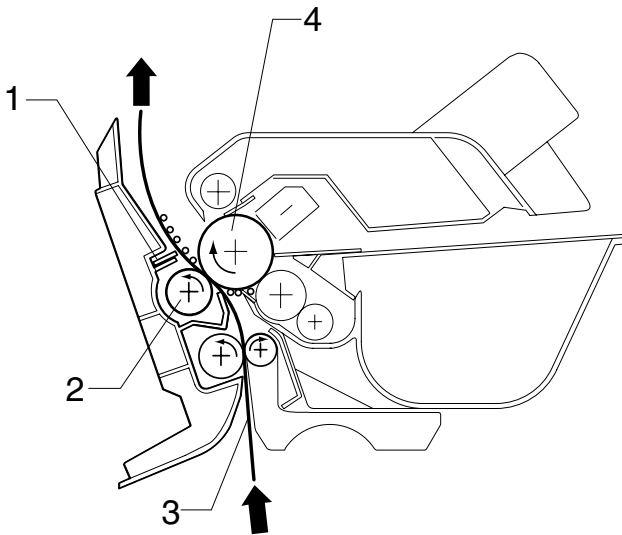

- 1 Discharge needle
- 2 Image transfer roller
- 3 Paper
- 4 PC Drum

4-8. Fusing section

- The toner transferred to the paper during the image transfer process is fused to the paper.
- A heat roller system is used as the fusing method. The toner is fused to the paper as it is pressed between the compression roller and the heat roller, heated by the heater lamp.

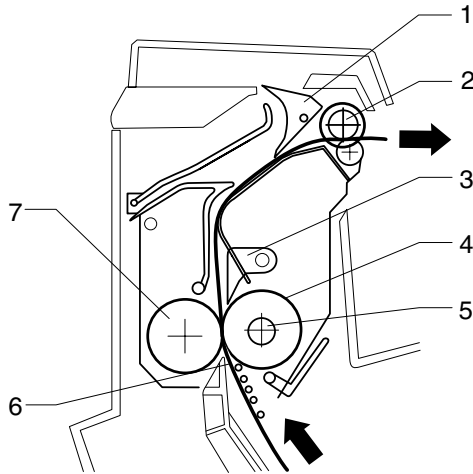

- 1 Entrance guide
- 2 Paper output roller
- 3 Paper separator of the fusing section
- 4 Heat roller
- 5 Heater (H1)
- 6 Paper
- 7 Compression roller

(1) Fusing temperature control circuit

- Thermistor 1 (TH1) detects the surface temperature of the fusing heat roller and inputs the analog voltage into the main control board (PWB-A). According to the temperature detected by thermistor 1 (TH1), the main control board (PWB-A) outputs the heater lamp ON/OFF signal to turn ON (lit) or OFF (not lit) the control of the temperature in the fusing section.

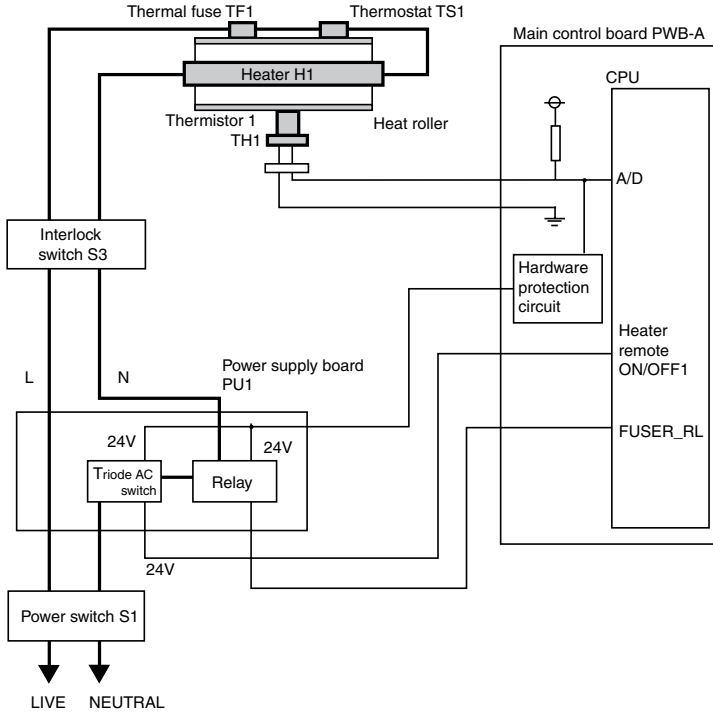

(2) Heater lamp control

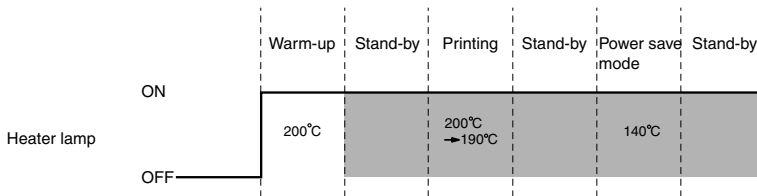

(3) Overview of temperature control modes during stand-by

When warm-up is finished, but printing is not started, the temperature is controlled with the modes described below, then goes into stand-by.

Mode	Temperature control
Mode 1	At 200 °C (392 °F) for 5 minutes (300 s)
Mode 2	Lowers the temperature from 200 °C to 185 °C (392 °F to 365 °F) in 60 seconds
Mode 3	185 °C (365 °F)

(4) Temperature control mode during stand-by: mode 1

The surface temperature of the heat roller during stand-by is maintained at 200 °C (392 °F). This mode continues for 5 minutes (300 s), and then the mode switches to mode 2.

(5) Temperature control mode during stand-by: mode 2

The surface temperature of the heat roller during stand-by is lowered from 200 °C to about 185 °C (392 °F to 365 °F) in 60 seconds. After the 60 seconds of this mode have finished, the control mode switches to mode 3.

(6) Temperature control mode during stand-by: mode 3

The surface temperature of the heat roller during stand-by is maintained at 185 °C (365 °F). This mode is maintained unless an error occurs or the top cover is opened.

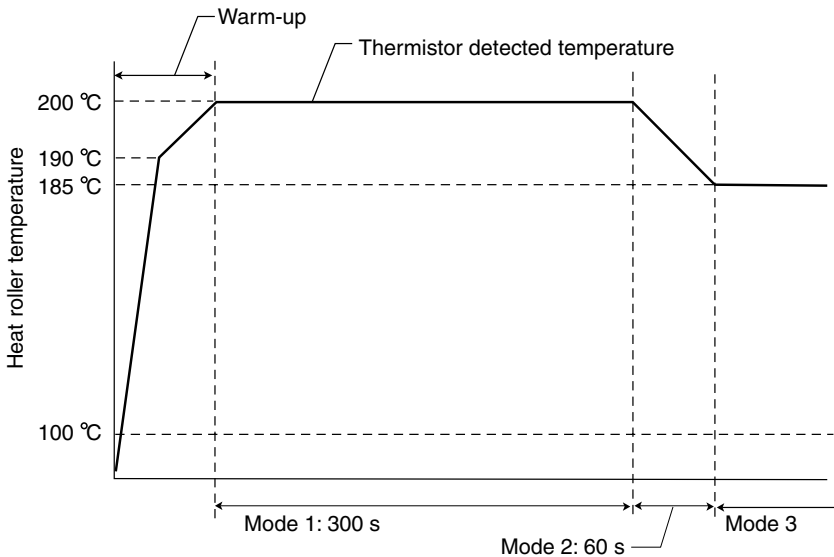

(7) Temperature control modes during printing

During printing, the temperature is controlled with the modes described below.

Mode	Temperature control
Mode 1	At $\langle X \rangle$ °C for $\langle Y \rangle$ seconds
Mode 2	Lowers the temperature from $\langle X \rangle$ °C to $\langle Z \rangle$ °C in 60 seconds
Mode 3	$\langle Z \rangle$ °C

Media	Time $\langle Y \rangle$
Ordinary paper (single-sided/double-sided), thick paper, postcards, overhead projector transparencies	300 s
Ordinary paper (small-sized, single-sided/double-sided), postcards (small-sized)	60 s
Thick paper (small-sized)	180 s

Media	Temperature $\langle X \rangle$	Temperature $\langle Z \rangle$
Ordinary paper (single-sided), thick paper, postcards, overhead projector transparencies	200 °C/392 °F	190 °C/374 °F
Ordinary paper (double-sided)		180 °C/356 °F
Ordinary paper (small-sized, single-sided/double-sided)	170 °C/338 °F	
Thick paper	210 °C/410 °F	
Thick paper (small-sized)	210 °C/410 °F	190 °C/374 °F
Postcards, postcards (small-sized)	210 °C/410 °F	200 °C/392 °F
Overhead projector transparencies	175 °C/347 °F	
Overhead projector transparencies (small-sized)	165 °C/329 °F	

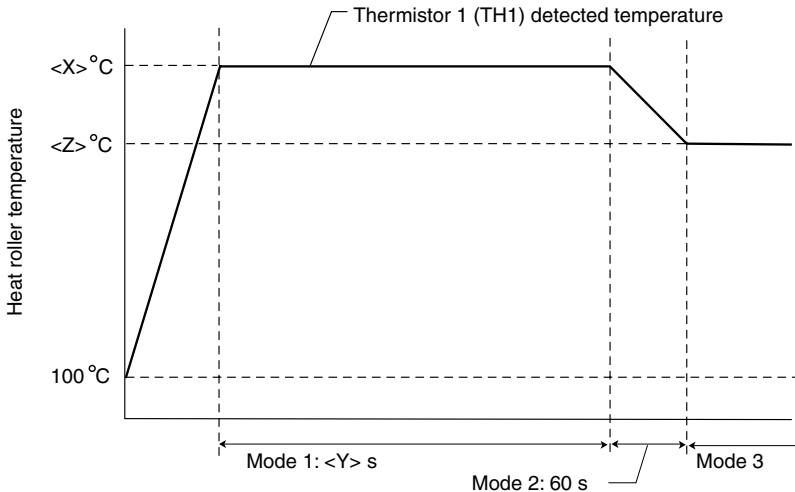

(8) Temperature control: software protection

- If thermistor 1 (TH1) detected a high-temperature malfunction but the heater (H1) is not turned OFF, the heater (H1) will be forcibly turned OFF (not lit) when the surface temperature of the heat roller exceeds 230 °C (446 °F).

(9) Temperature control: hardware protection

- If, for some reason, the software protection is not activated (for example, if the microcomputer loses control or malfunctions), the DC 24 V circuit for the heater remote is cut when the surface temperature of the heat roller exceeds 250 °C (482 °F).

(10) Temperature control: overheat protection

- If, for some reason, the hardware protection is not activated (for example, if thermistor 1 is incorrect or is damaged), the thermostat (TS1) is activated when the temperature of the nip section of the heat roller surface exceeds 450 °C (842 °F), and then the circuit conducting electricity to the heater (H1), the DC 24 V circuit and the relays are forcibly cut.
- As an added protection, if, for some reason, the thermostat (TS1) is not activated, the thermal fuse is cut when the temperature of the nip section of the heat roller surface exceeds 450 °C (842 °F), and the circuit conducting electricity to the heater lamp is forcibly cut.

Note

If the thermostat (TS1) is activated, it must be replaced, and not used again. (thermostat recovery temperature: 0 °C (32 °F))

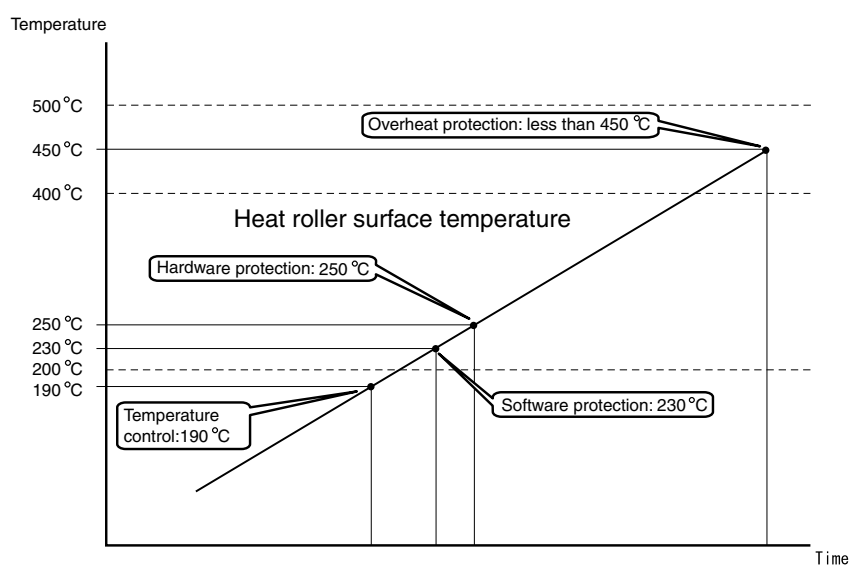

4-9. Paper exit section

- The paper output roller is driven by the main motor (M1) and rotated in the normal direction (paper output direction: counterclockwise). The paper is fed out into the face-down output tray with the printed side facing down.

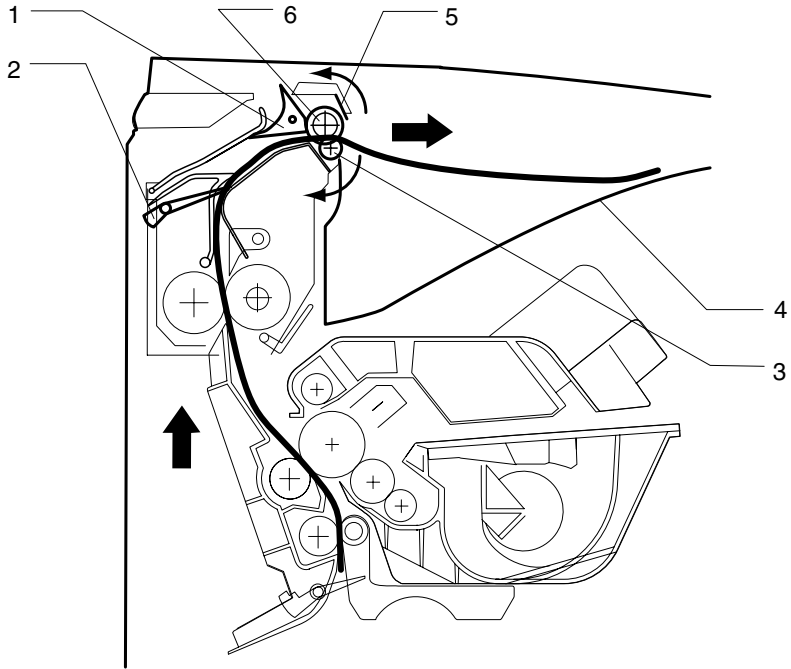

- 1 Entrance guide
- 2 Paper output sensor actuator
- 3 Paper output roll
- 4 Face-down output tray
- 5 Discharge brush
- 6 Paper output roller

(1) Paper-full detection mechanism

- The actuator of the paper-full detection sensor (PS3) is raised by the paper fed with the heat roller. The raised actuator allows the sensor light to pass through.
- When paper is fed into the face-down output tray, the actuator returns to its original position through its own weight, interrupting the sensor light.
- As the paper fed into the face-down output tray increases, when the actuator angle decreases to 20° or more and after the length of time that the sensor light has passed through exceeds 8 seconds, it is determined that the tray is full.

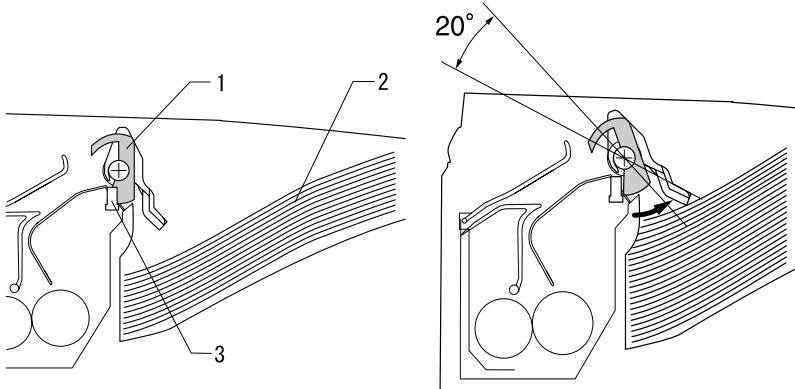

- 1 Paper-full detection sensor actuator
- 2 Paper
- 3 Paper-full detection sensor (PS3)

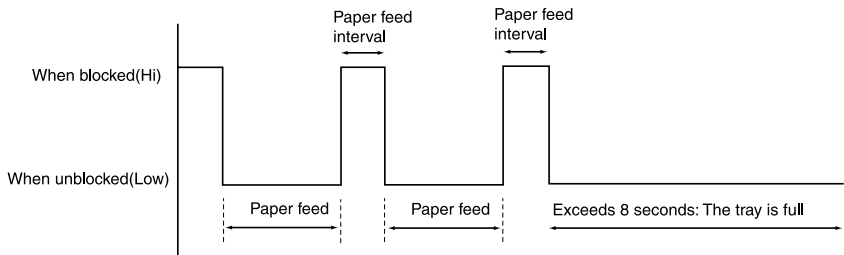

(2) Paper output roller drive-switching mechanism

- When the optional duplex unit is installed, the paper output idler lever of the duplex unit raises the drive gear assembly of the fusing unit. The raised drive gear assembly is linked with the drive gear of the switchback motor (M2) in the duplex unit. This switches the drive source of the paper output roller from the main motor (M1) to the switchback motor (M2) of the duplex unit.

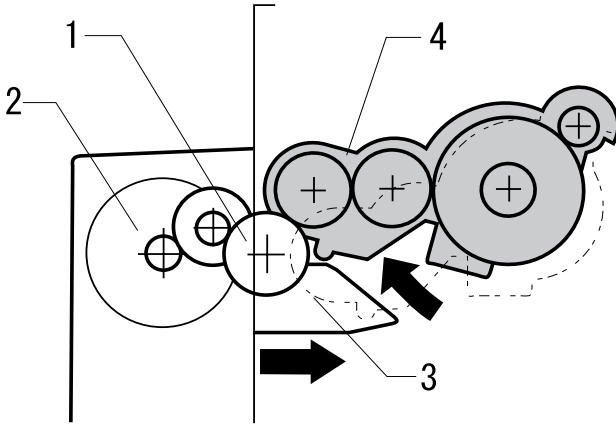

- 1 Drive gear
- 2 Switchback motor (M2)
- 3 Paper output idler lever
- 4 Drive gear assembly.

(3) Paper-output-switching mechanism

- When the entrance guide lever of the optional 4-bin mailbox presses down on the entrance guide of the fusing unit, the angle of the entrance guide changes. Instead of the fed paper being transported by the paper output roller, it is fed out to the mailbin directed by the entrance guide.

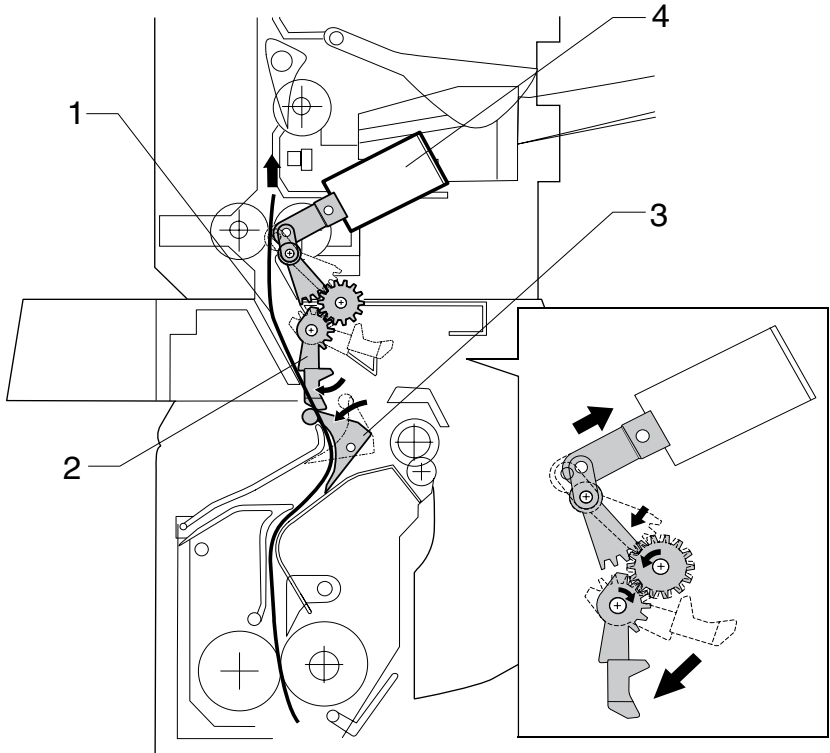

- 1 Paper
- 2 Entrance guide lever
- 3 Entrance guide
- 4 Entrance guide switching solenoid

4-10. Duplex section (optional duplex unit)

(1) Overview

- The paper output roller is driven by the main motor (M1) via the duplex lever assembly, and rotated in the normal direction (paper output direction: counterclockwise).
- By installing the optional duplex unit, the paper output idler lever of the duplex unit raises the drive gear assembly. of the fusing unit. The raised drive gear assembly is linked with the drive gear of the switchback motor (M2) in the duplex unit. This switches the drive source of the paper output roller from the main motor (M1) to the switchback motor (M2) of the duplex unit. Therefore, the paper output roller can rotate in the normal direction (paper output direction: counterclockwise) or in reverse (paper feed direction: clockwise).

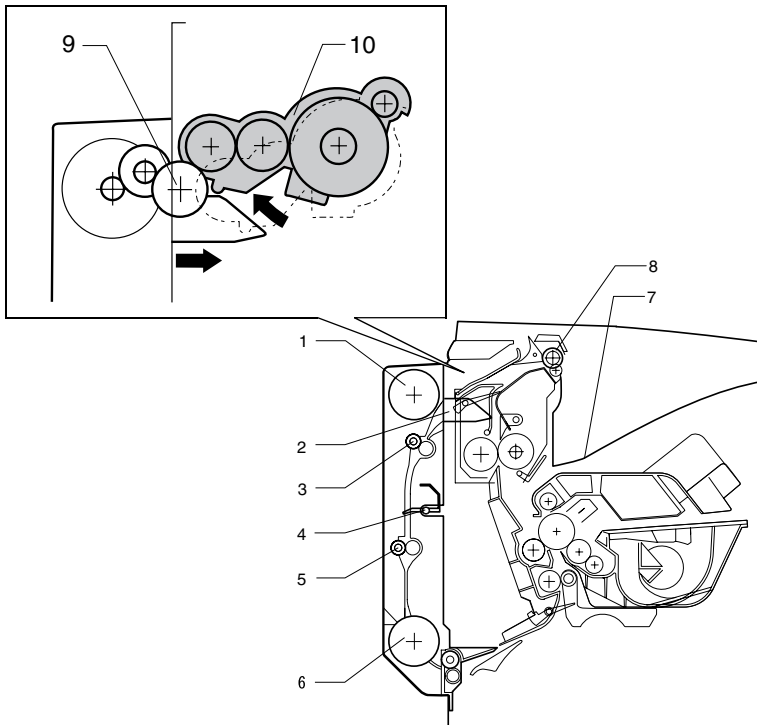

- 1 Switchback motor (M2)
- 2 Paper output idler lever
- 3 Upper transport roller
- 4 Duplex unit paper sensor
- 5 Lower transport roller
- 6 Transport motor (M1)
- 7 Face-down output tray
- 8 Paper output roller
- 9 Connection gear
- 10 Drive gear assembly.

(2) Single-sided printing mechanism

- The actuator of the paper output sensor (PC3) is raised by the paper fed by the heat roller, blocking the sensor light. When the sensor light is interrupted, the sensor determines that paper is present.
- The switchback motor (M2) of the duplex unit rotates in reverse, which rotates the paper output roller of the fusing unit in the normal direction (paper feed direction), to transport the paper into the face-down output tray.
- The paper fed by the paper output roller contacts the discharge brush on the top rear cover, and any residual electric potential in the paper is dissipated.
- With the paper passing through, the actuator of the paper output sensor (PC3) is lowered. Since the actuator no longer blocks the sensor light and allows it to pass through, the sensor determines that the paper has been outputted.
- The paper is fed out to the face-down output tray.

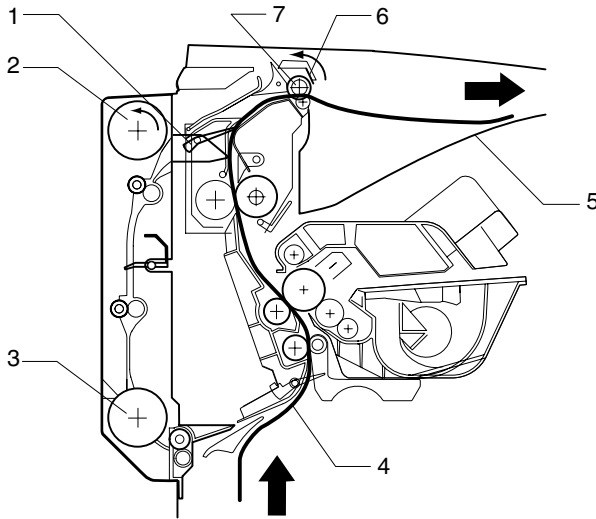

- 1 Paper output sensor (PC3)
- 2 Switchback motor (M2)
- 3 Transport motor (M1)
- 4 Paper
- 5 Face-down output tray
- 6 Discharge brush
- 7 Paper output roller

(3) Double-sided printing mechanism

- With the paper passing by the paper output sensor (PC3), the actuator of the paper output sensor (PC3) is lowered. Since the actuator no longer blocks the sensor light and allows it to pass through, the sensor detects that the paper has passed.
- The switchback motor (M2) of the duplex unit switches to rotating in the normal direction, which rotates the paper output roller of the fusing unit in reverse, to feed the paper back into the duplex unit (switchback).
- The transport motor (M1) of the duplex unit rotates, which rotates the upper transport roller, lower transport roller, and the feed-back roller. The upper transport roller transports the paper to the center of the duplex unit.
- The actuator of the duplex unit paper sensor (PC2) is lowered by the paper fed by the upper transport roller, blocking the sensor light. When the sensor light is interrupted, the duplex unit paper sensor (PC2) detects the paper.
- The lower transport roller transports the paper to the feed-back roller.
- The feed-back roller transports the paper to the transport roller of the printer.
- With the paper passing through, the actuator of the duplex unit paper sensor (PC2) is raised. Since the actuator no longer blocks the sensor light and allows it to pass through, the duplex unit paper sensor (PC2) determines that the paper has been fed again from the duplex unit.
- Afterwards, the control is the same as with single-sided printing.

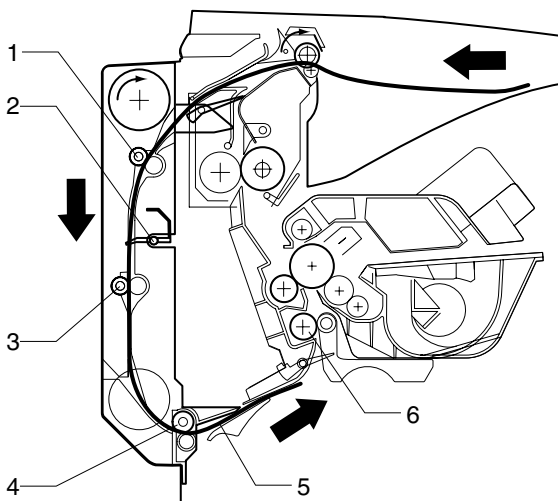

- 1 Upper transport roller
- 2 Duplex unit paper sensor (PC2)
- 3 Lower transport roller
- 4 Feed-back roller
- 5 Paper
- 6 Transport roller

4-11. Sorting section (optional 4-bin mailbox)

(1) Drive mechanism

- If the paper arrives in front of the entrance guide in the paper feed-out section of the printer, the transport motor (M1) of the 4-bin mailbox rotates, rotating the transport roller and bin output roller via timing belts.
- When the trailing edge of the last page passes the lower transport sensor (PC9) or the upper transport sensor (PC10), the transport motor stops.

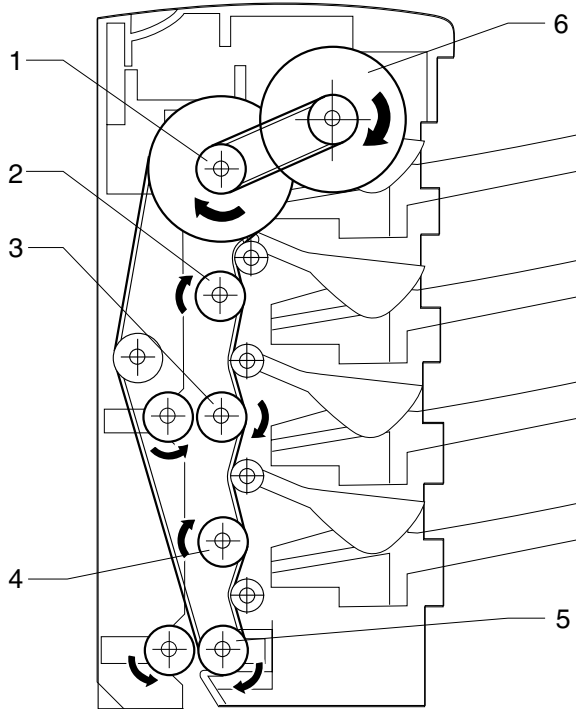

- 1 Bin output roller (mailbin 4)
- 2 Bin output roller (mailbin 3)
- 3 Bin output roller (mailbin 2)
- 4 Bin output roller (mailbin 1)
- 5 Transport roller
- 6 Transport motor (M1)

(2) Paper-switching mechanism

- When the entrance guide switching solenoid (SL1) is activated, and the entrance guide lever of the 4-bin mailbox presses down on the entrance guide of the fusing unit, the position of the entrance guide switches.
- At the same timer, the transport motor (M1) of the 4-bin mailbox starts rotating.
- The paper fed out from the printer is directed into a mailbin by the entrance guide.
- The paper is transported into the mailbin by the transport roller (M1).

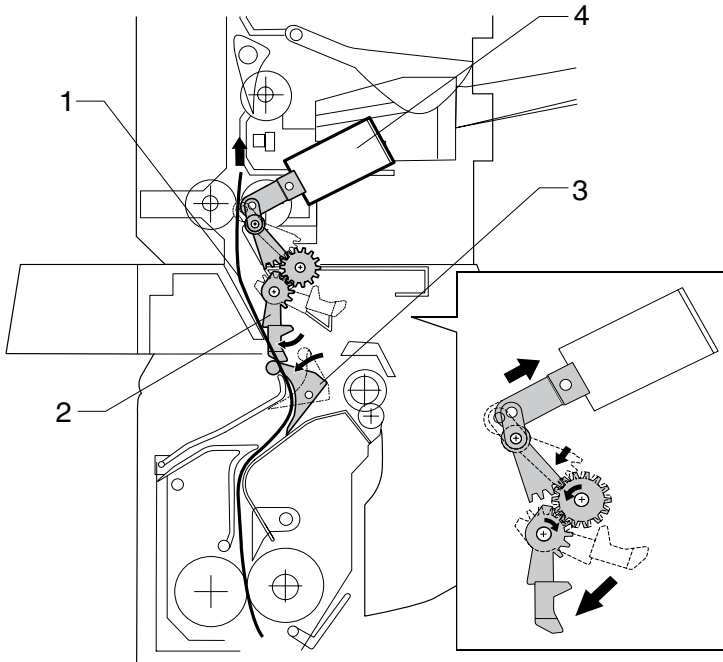

- 1 Paper
- 2 Entrance guide lever
- 3 Entrance guide
- 4 Entrance guide switching solenoid (SL1)

(3) Bin-switching mechanism

- When the bin entrance switch solenoid (SL2 through SL4) is activated, the position of the bin entrance switch changes.
- The fed paper is directed into the mailbin by the bin entrance switch.
- The fed paper is transported to the mailbin by the bin output roller.

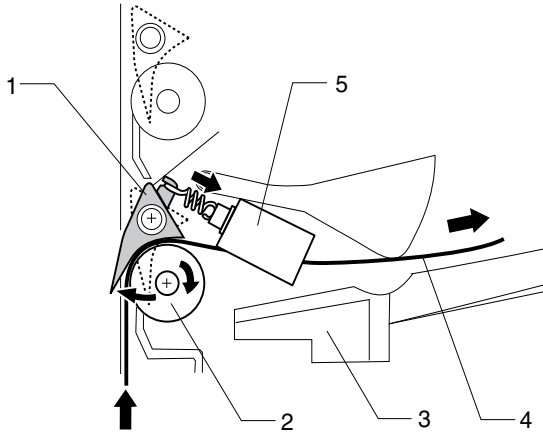

- 1 Bin entrance switch
- 2 Bin output roller
- 3 Mailbin
- 4 Paper
- 5 Bin entrance switching solenoid (SL2 through SL4)

(4) Fed paper detection mechanism

- The 4-bin mailbox is equipped with bin empty sensors (PC1~PC4), which monitor whether paper is present in the mailbins.
- When there is no paper in the mailbin, the actuator is in the lowered position. A lowered actuator blocks the sensor light, enabling the bin empty sensor to determine that there is no paper in the mailbin.
- When paper is present in the mailbin, the actuator is raised by the paper. A raised actuator allows the sensor light to pass through, enabling the bin empty sensor to determine that paper is present in the mailbin.

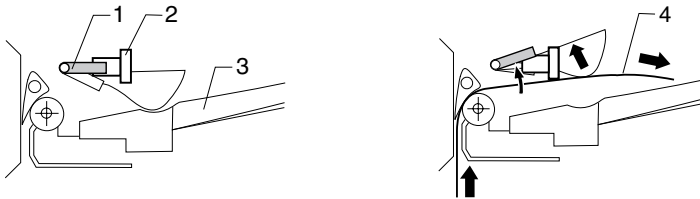

- 1 Actuator
- 2 Bin empty sensor (PC1~PC4)
- 3 Mailbin
- 4 Paper

(5) Full mailbin detection mechanism

- The 4-bin mailbox is equipped with bin full sensors (PC5~PC8), which monitor the amount of paper in the mailbins.
- When there is not too much paper in the mailbin, the actuator is in the lowered position. A lowered actuator allows the sensor light to pass through, enabling the bin full sensor to determine that there are not too many sheets of paper present in the mailbin.
- When the number of sheets in the mailbin exceed the specification (50 sheets of paper with a weight of 80 g/m²), the actuator is raised by the paper. A raised actuator blocks the sensor light, enabling the bin full sensor to determine that the number of sheets in the mailbin have reached the specification.

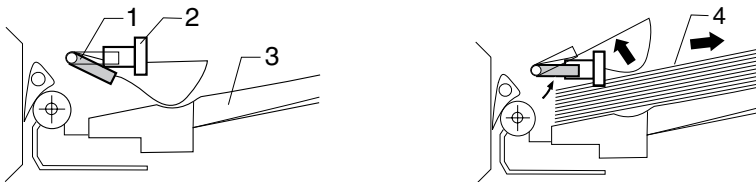

- 1 Actuator
- 2 Bin full sensors (PC5~PC8)
- 3 Mailbin
- 4 Paper

5. MAINTENANCE/DISASSEMBLY

5-1. Precautions for maintenance/disassembly

(1) Precautions for disassembly

Observe the following precautions whenever servicing the printer.

- Be sure to unplug the printer from the outlet before attempting to service the printer.
- To reassemble the printer, reverse the order of disassembly unless otherwise specified.
- The basic rule is not to operate the printer anytime during disassembly. If it is absolutely necessary to run the printer with its covers removed, use care not to allow your clothing to be caught in revolving parts such as the gears, rollers and motor.
- Never touch the terminals of electrical parts or high-voltage parts such as the high voltage unit.
- Be sure to handle the fusing unit carefully as the unit is still hot for a while after the printer is stopped.
- Always unplug connectors by holding the connector housing.
- Be sure to use the fuse of the specified rating
- Do not forget to install the ground wire or ground plate to ensure positive conduction. Install the screw with a toothed washer in the right position at reassembly.

(2) Parts that must not be touched

- Never disassemble or adjust the print head unit or the mirror unit.
- Never remove, disassemble, or adjust the parts with mounting screws that are painted red.

(3) During transportation/storage the PWBs with MOS ICs:

The following precautions must be observed when handling circuit boards with MOS (metal oxide semiconductor) ICs.

- During transportation or when in storage, new circuit boards must not be indiscriminately removed from their protective conductive bags.
- Do not store or place circuit boards in a location exposed to direct sunlight.
- When it becomes absolutely necessary to remove a board from its conductive bag or case, always place it on its conductive mat in an area as free as possible from static electricity.

(4) During replacement the PWBs with MOS ICs:

- Before unplugging connectors from the circuit boards, make sure that the power cord has been unplugged from the power outlet.
- When removing a board from its conductive bag or case, do not touch the pins of the ICs or the printed pattern. Place it in position by holding only the edges of the board.
- Before plugging connectors into the board, make sure that the power cord has been unplugged from the power outlet.

(5) During Inspection the PWBs with MOS ICs:

- Avoid checking the IC directly with a multi-meter; use connectors on the board.
- Never create a closed circuit across IC pins with a metal tool.
- Where it is absolutely necessary to touch the ICs and other electrical components on the board, be sure to ground your body.

(6) During transportation/storage the imaging cartridge:

- Use the specified carton whenever moving or storing the imaging cartridge.
- The storage temperature is in the range between $-20^{\circ}\text{C}/-4^{\circ}\text{F}$ and $+40^{\circ}\text{C}/104^{\circ}\text{F}$.

(7) Handling the imaging cartridge:

- As the P.C. drum is extremely sensitive to light fatigue and takes long time to recover sensitivity, never open the protection cover or expose the P.C. drum to direct sunlight for long periods time.
- Use care not to contaminate the surface of the P.C. drum with oil-base solvent, fingerprints, and other foreign matter.
- Do not scratch the surface of the P.C. drum.

5-2. Cleaning schedule





Part name	Cleaning cycle
Paper take-up roller (multi-purpose paper tray of the printer)	When a paper misfeed occurs
Image transfer roller unit (printer)	When a malfunction such as poor image transferring occurs
Transport roller (optional duplex unit)	When a paper transport error occurs
Transport roller (optional lower feed unit)	When a paper transport error occurs
Transport roller (optional 4-bin mailbox)	When a paper transport error occurs

5-3. Maintenance schedule



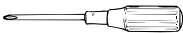

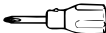
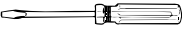
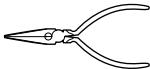
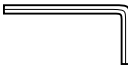













Part name	Replacement cycle (multi-page printing)	Replacement cycle (single-page printing)
Start-up imaging cartridge (includes the exhaust filter)	Average: approximately 6,000 or more prints	
Replacement imaging cartridge (include the exhaust filter)	Average: approximately 15,000 or more prints	Average: approximately 12,000 or more prints
	Minimum: approximately 12,000 or more prints	Minimum: approximately 9,600 or more prints
Paper take-up roller (multi-purpose paper tray of the printer)	Approximately 150,000 prints	
Paper take-up roller (lower feed unit of the printer)	Approximately 200,000 prints	
Paper-separating roller (lower feed unit of the printer)		
Image transfer roller unit (printer)	Approximately 150,000 prints	
Fusing unit (printer)	Approximately 500,000 prints	Approximately 300,000 prints
Paper take-up roller (optional lower feed unit)	Approximately 200,000 prints	
Paper-separating roller (optional lower feed unit)		

*The imaging cartridge is a user-replaceable item.

5-4. Required service tools

Tools			
Phillips screwdriver (No. 1) 	Phillips screwdriver (No. 2) 	Stubby screwdriver (Phillips) 	Flat screwdriver 
Radio pliers 	Wrench (4 mm) 	Core driver 	

5-5. List of screws used

Illust.	No.	Type	Illust.	No.	Type	Illust.	No.	Type
	0509 0513 0601	Pin		3334	Tapping screw		5129	Bolt
	1305 1308 1309 1318	Screw		3403	Tapping screw		5901 5902	Screw
	1607 1602	Screw		3501 3504 3524 3541 3542 3544 3546 3547	Tapping screw		5903	Screw
	1801	Screw (with toothed washer)		3701 3704 3705 3708 3709 3716 3717 3727 3730 3734 3803	Tapping screw		9102 9107 9109 9112 9115	E-clip
	2505	Screw		3906 3907 3914 3929	Tapping screw		9301	C-clip (resin)
	2911	Screw (with spring washer)		4021	Tapping screw			
	3104	Tapping screw		4501	Screw			

5-6. Printer disassembly procedures

(1) Disassembly procedure chart

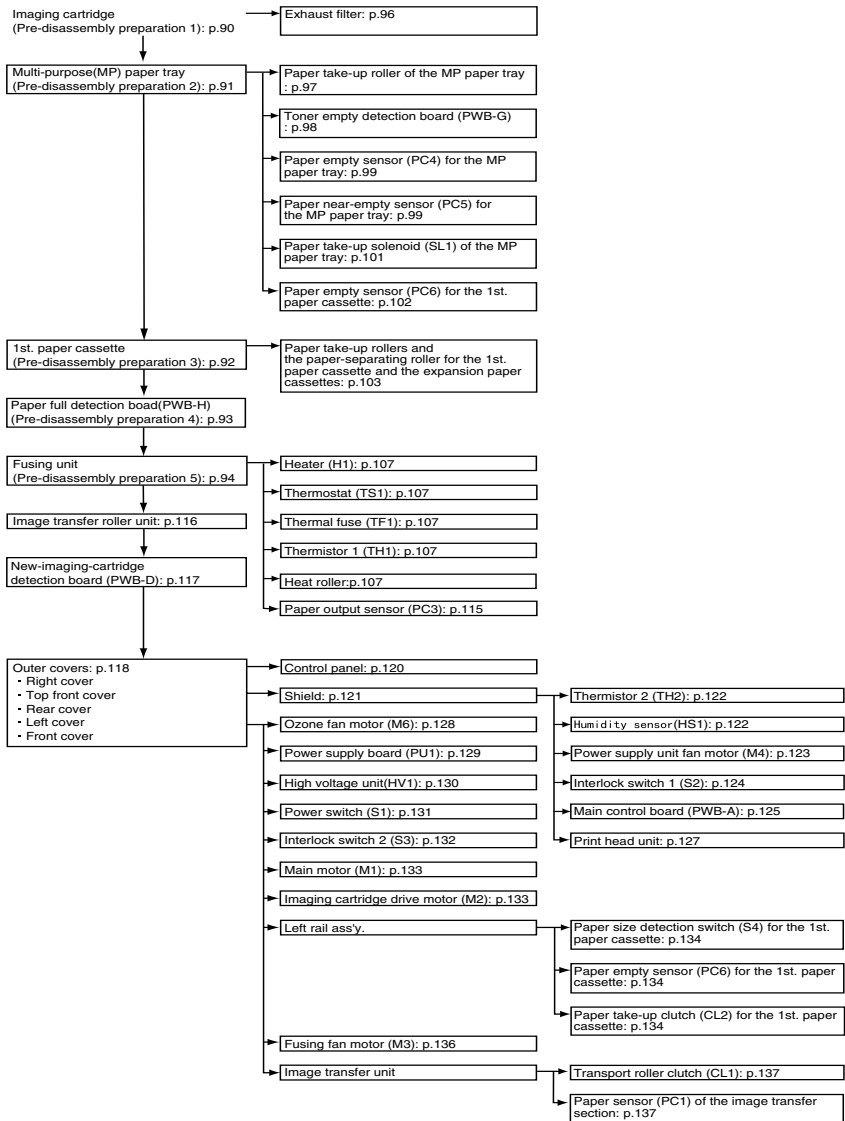

(2) Pre-disassembly preparation 1 (removing the imaging cartridge)

Before disassembling the machine, the following units need to be removed as pre-disassembly preparation.

- Imaging cartridge
- Multi-purpose paper tray
- first paper cassette
- Fusing unit

1. Press the top rear cover release button, and then fully open the top cover.
2. Lower the top rear cover stopper to secure the top cover.
3. Remove the imaging cartridge.

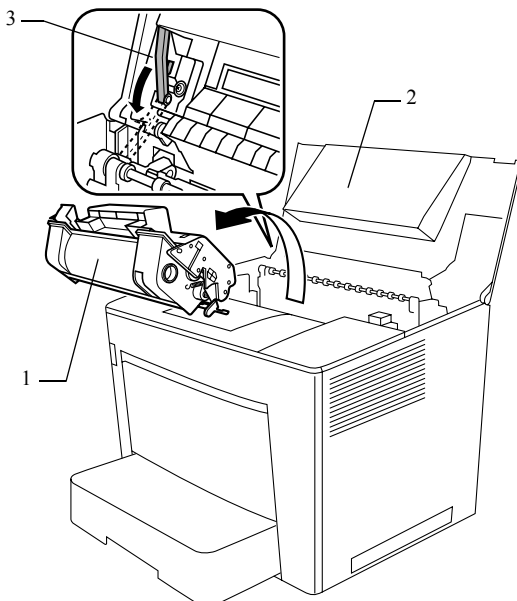

1 Imaging cartridge

3 Top rear cover stopper

2 Top rear cover

Note

- Before closing the top rear cover, be sure to release its stopper, carefully return the top rear cover to its lowered position, and then securely close it. If the top rear cover is closed without first releasing the stopper, the cover may be damaged.
 - Be sure to also replace the exhaust filter when the imaging cartridge is replaced. If the printer is used with a dusty filter, the cooling efficiency of the inside of the printer is reduced, resulting in damage to or malfunction of the printer. The exhaust filter is not needed when a duplex unit is attached.
-

(3) Pre-disassembly preparation 2 (removing the multi-purpose paper tray)

1. Swing open the lower transport guide.
2. Open the multi-purpose paper tray.
3. Remove the multi-purpose paper tray stopper (three tabs).
4. Raise the tab on the locking shaft for the multi-purpose paper tray, and then pull up on the locking shaft.
5. Remove the multi-purpose paper tray.

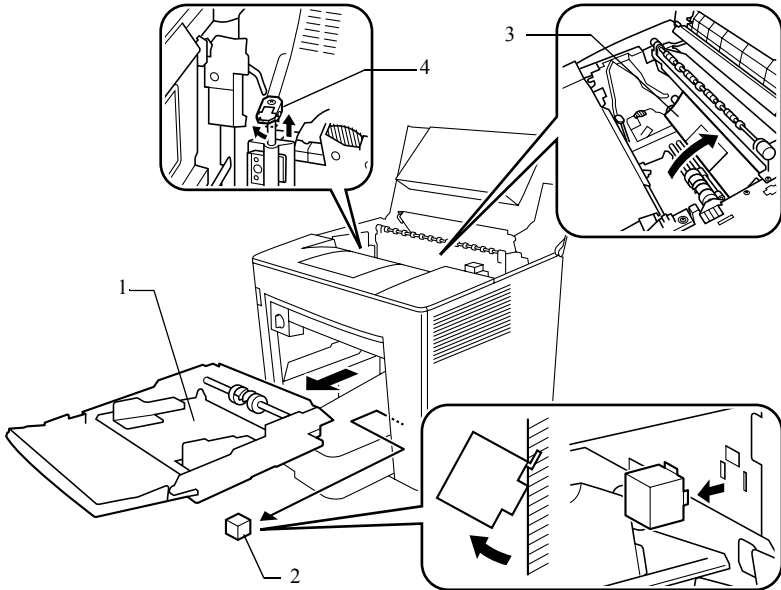

- 1 Multi-purpose paper tray
- 2 Multi-purpose paper tray stopper
- 3 Lower transport guide
- 4 Locking shaft for the multi-purpose paper tray

(4) Pre-disassembly preparation 3 (removing the first paper cassette)

1. Pull out the first paper cassette about 100 mm.
2. Press in the cassette release buttons on both sides of the cassette, and then remove the first paper cassette.

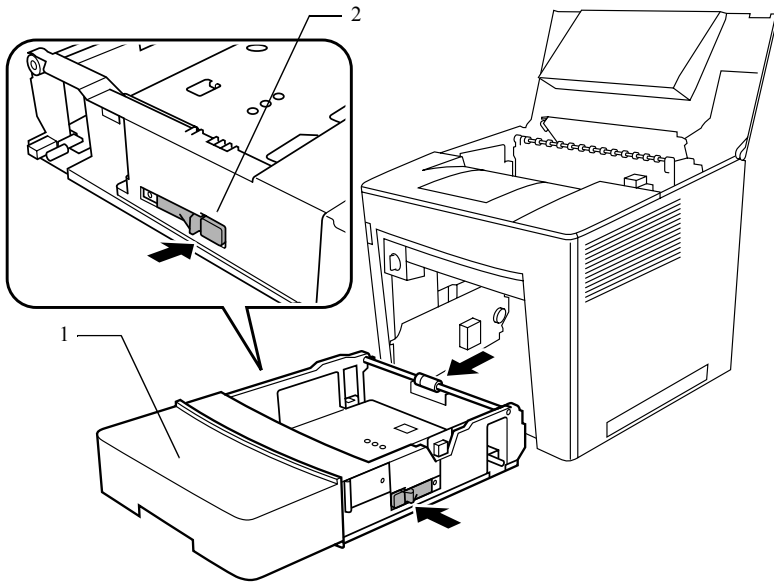

- 1 first paper cassette
- 2 Cassette release button

(5) Pre-disassembly preparation 4 (removing the paper-full detection board)

1. Remove the board holder (1 screw).
2. Remove the paper-full detection board (PWB-H) (1 screw and 1 connector).

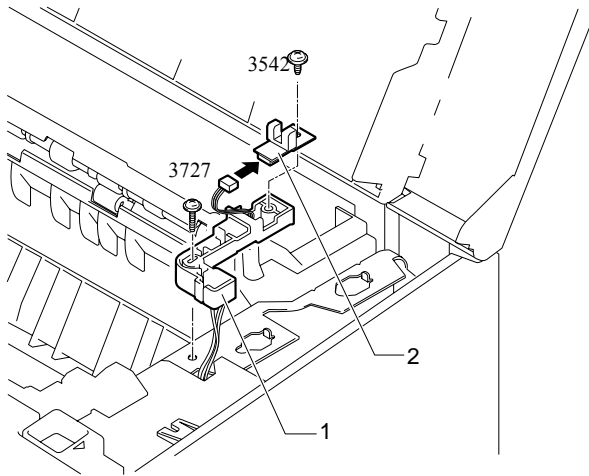

- 1 Board holder
- 2 Paper-full detection board (PWB-H)

Note

- When installing the board holder, make sure that the holder fits against the fusing unit.

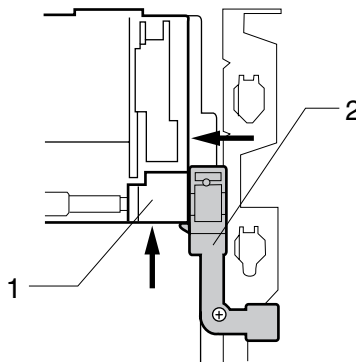

- 1 Fusing unit
- 2 Board holder

(6) Pre-disassembly preparation 5 (removing the fusing unit)

1. Remove the duplex unit mounting cover (1 shoulder screw).
2. Remove the cover for the fusing unit connector (1 screw).
3. Remove the screws securing the fusing unit (2 shoulder screws).
4. Disconnect the two connectors.

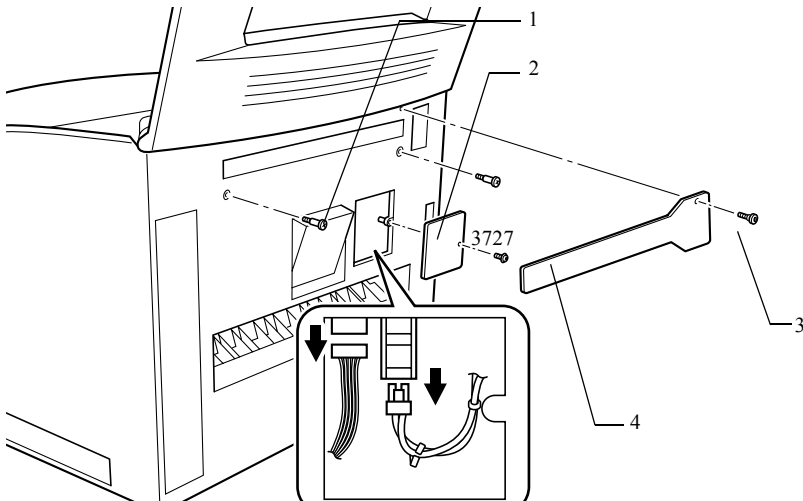

- 1 Shoulder screw
- 2 Fusing unit connector cover
- 3 Shoulder screw
- 4 Duplex unit mounting cover

Note

- When installing the covers, be sure to first insert the tab on each cover into the rear of the printer before putting the cover back into place.
-

5. Remove the belt (1 screw).
6. Remove the fusing unit (3 screws).

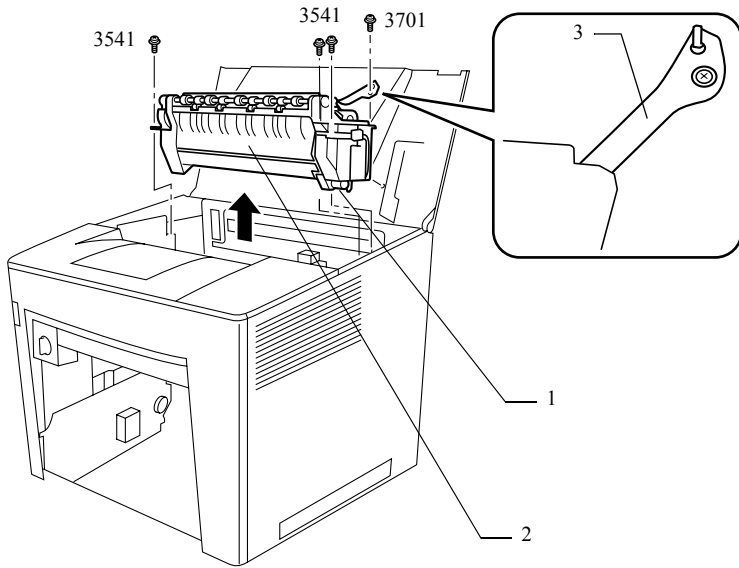

- 1 Guide Pins
- 2 Fusing unit
- 3 Belt

Note

- *When installing a fusing unit, be sure to install the belt.*
 - *When installing a fusing unit, make sure that the guide pins (two on the left and one on the right) on the fusing unit fit into their corresponding holders in the printer frame.*
-

(7) Replacing the exhaust filter

1. Remove the exhaust filter.

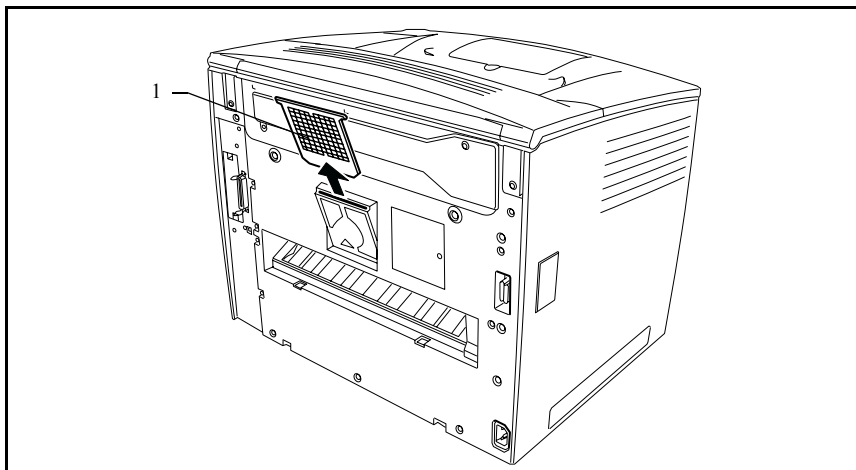

1 Exhaust filter

Note

- Be sure to also replace the exhaust filter when the imaging cartridge is replaced. If the printer is used with a dusty filter, the cooling efficiency of the inside of the printer is reduced, resulting in damage to or malfunction of the printer.
 - If the printer is used in an extremely dusty environment, use a vacuum cleaner to clean the exhaust filter when necessary. Do not clean the filter with the water.
 - Dispose of the used exhaust filter in accordance with local regulations.
 - Remove the exhaust filter before attaching a duplex unit to the printer. The exhaust filter is not needed when a duplex unit is attached.
-

(8) Replacing the paper take-up roller of the multi-purpose paper tray

1. Remove the paper take-up roller.

Note

- When installing a roller, make sure that the positioning pin on the back of the roller fits into the hole in the paper take-up roller drive shaft before securing the roller with the screw.
-

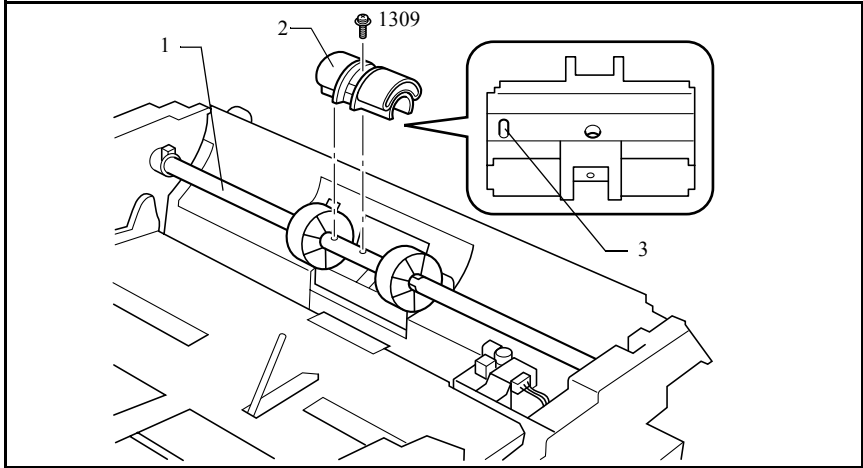

- 1 Paper take-up roller drive shaft
- 2 Paper take-up roller
- 3 Positioning pin

Note

- Never touch the surface of the paper take-up roller or allow it to become contaminated with chemicals or toner, etc. Any scratching or contamination of the paper take-up roller will affect paper feeding.
-

(9) Replacing the toner empty detection board (PWB-G)

1. Remove the toner empty detection board (PWB-G) assembly (1 screw and 1 connector).

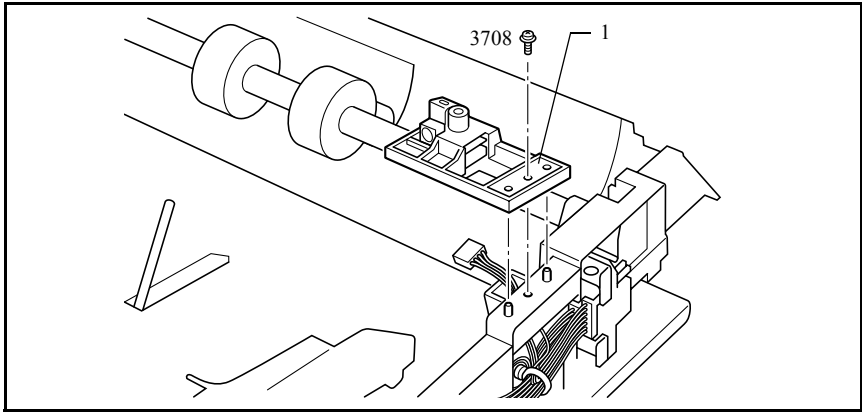

- 1 Toner empty detection board (PWB-G) assembly.

(10) Replacing the paper empty sensor (PC4) and the paper near-empty sensor (PC5) for the multi-purpose paper tray

1. Remove the mounting screw securing the paper-lifting plate assembly (1 screw and 1 washer).
2. Insert flat screwdrivers between the frame of the paper tray and the paper-lifting plate (one at the left and one at the right).
3. Move the screwdrivers to the outside in order to stretch the frame of the paper tray.
4. With the screwdrivers, gently pry up the paper-lifting plate, and then remove the paper-lifting plate assembly (1 washer).
5. Remove the photo sensor assembly (one connector).
6. Remove the paper empty sensor (PC4) and the paper near-empty sensor (PC5) from the photo sensor assembly.

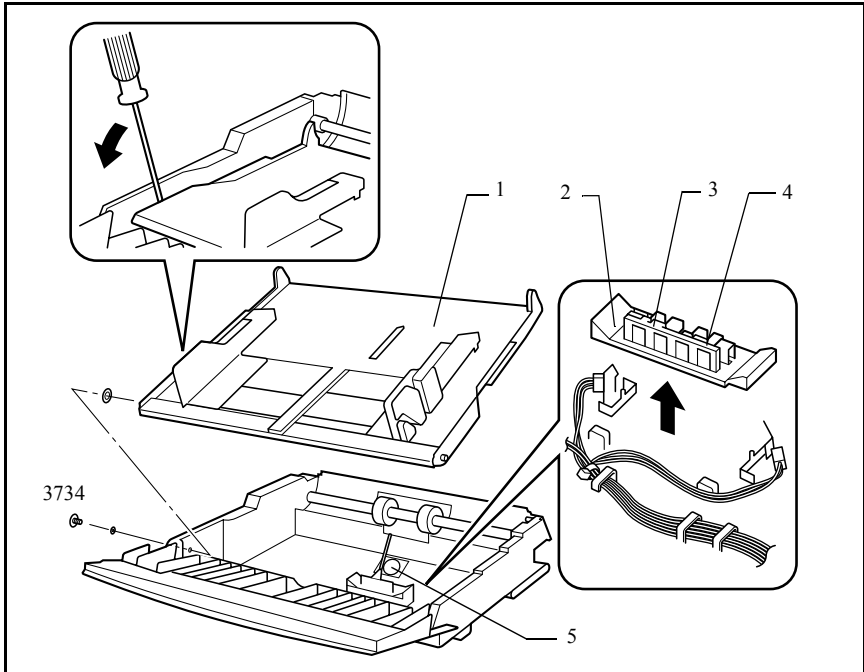

- 1 Paper-lifting plate assembly.
- 2 Photo sensor assembly.
- 3 Paper near-empty sensor (PC5)
- 4 Paper empty sensor (PC4)
- 5 Compression coil spring seat

Note

- When installing a paper-lifting plate, as with removing it, insert a flat screwdriver between the paper-lifting plate and the frame of the paper tray, stretch the frame of the tray, and then install the paper-lifting plate assembly.
- When installing a paper-lifting plate, make sure that the end of the compression coil spring at the bottom of the paper-lifting plate is hooked onto the bracket as shown in the illustration.

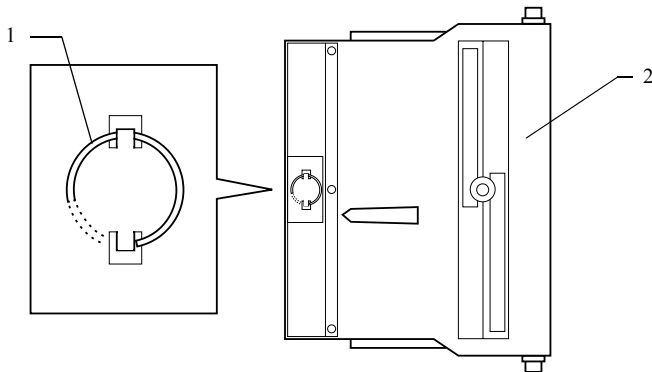

- 1 Compression coil spring
- 2 Paper-lifting plate

- When installing a paper-lifting plate, make sure that the compression coil spring at the bottom of the paper-lifting plate fits into the corresponding spring seat in the paper cassette frame.

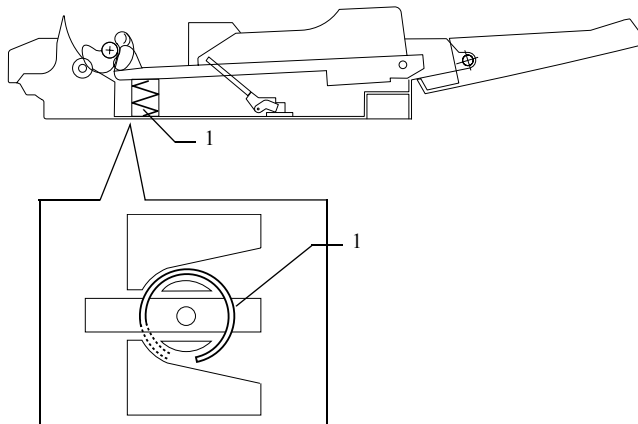

- 1 Compression coil spring
-

(11) Replacing the paper take-up solenoid (SL1) of the multi-purpose tray

1. Remove the paper take-up solenoid (SL1) (1 screw and 1 connector).

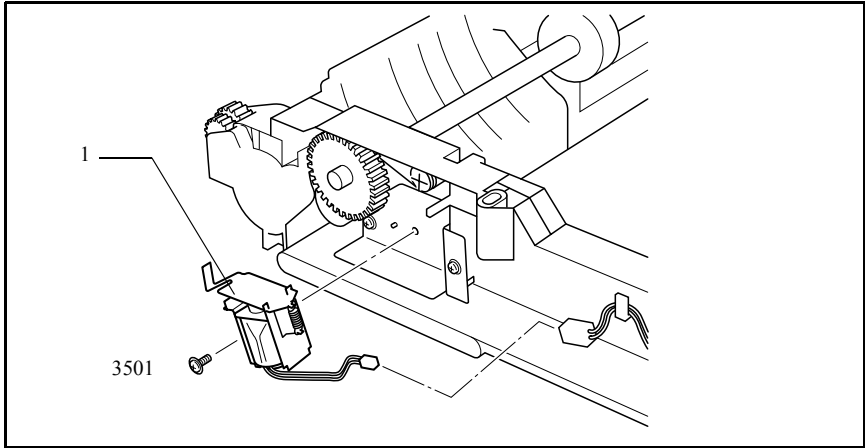

- 1 Paper take-up solenoid (SL1)

Note

- When installing a paper take-up solenoid (SL1), make sure that the end of the solenoid actuator hooks onto the cam of the paper take-up roller drive gear.

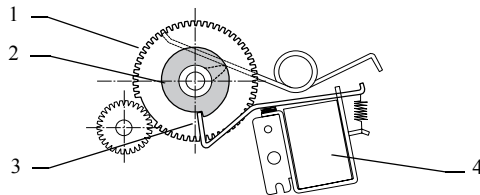

- 1 Paper take-up roller drive gear
- 2 Cam
- 3 Actuator
- 4 Paper take-up solenoid (SL1)

(12) Replacing the paper empty sensor (PC6) for the first paper cassette

1. Remove the sensor cover (1 screw).
2. Remove the paper empty sensor (PC6) for the first paper cassette (1 screw and 1 connector).

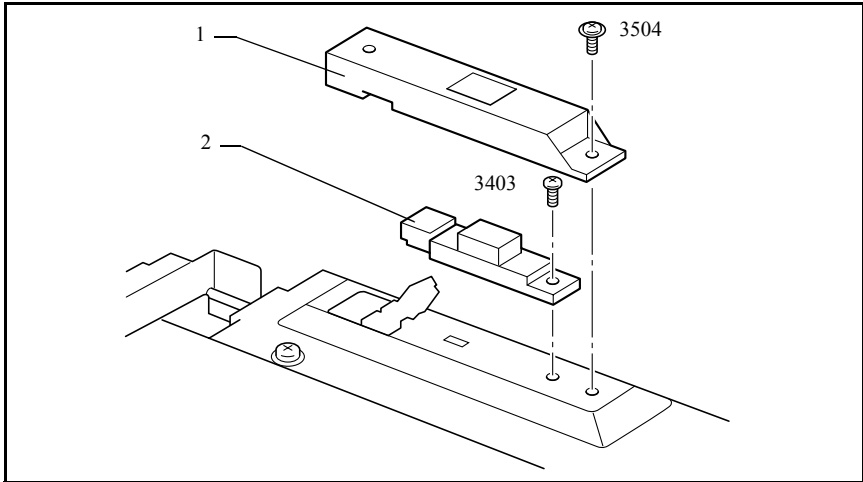

- 1 Sensor cover
- 2 Paper empty sensor (PC6) for the first paper cassette

(13) Replacing the paper take-up rollers and the paper-separating roller for the first paper cassette and the expansion paper cassettes

1. Remove the paper-separating roller assembly. (2 screws).

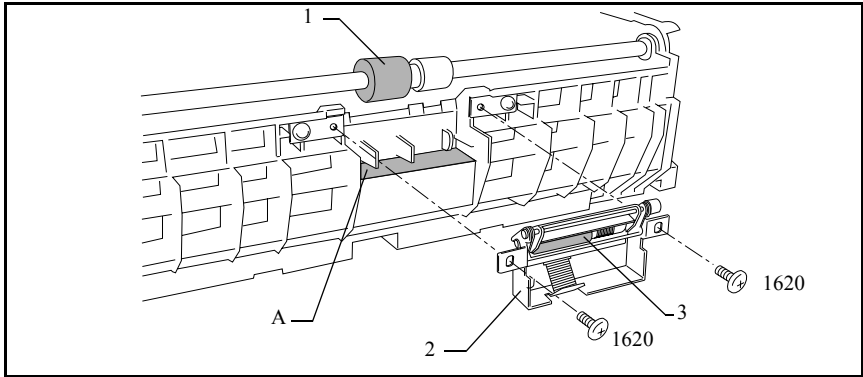

- 1 Paper take-up roller
2 Paper-separating roller assembly.
3 Paper-separating roller

Note

- Never touch the surface of the paper-separating roller or allow it to become contaminated with chemicals or toner, etc. Any scratching or contamination of the paper-separating roller will affect paper feeding.
- When installing a paper-separating roller assembly, be sure to secure it with the screws so that it fits against surface A shown in the illustration. At that time, make sure that the surface of the paper-separating roller contacts the surface of the paper take-up roller.

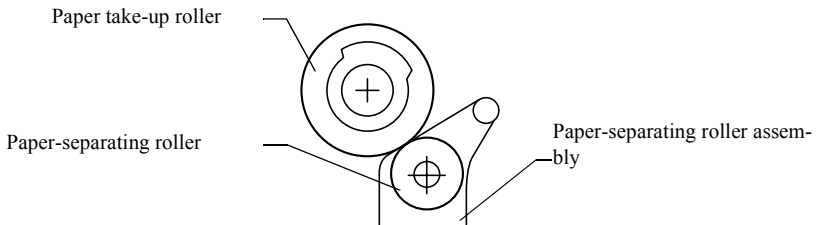

2. Remove the coil spring.
3. Remove the collar from the shaft.
4. Pull the shaft out of the paper-separating roller assembly.
5. Remove the bracket.

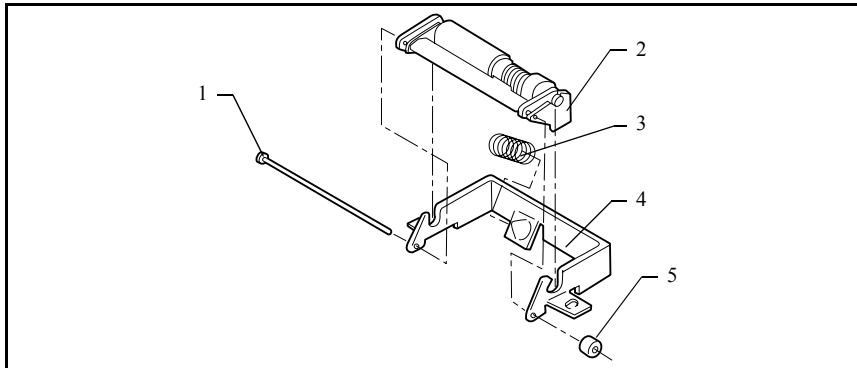

- 1 Shaft
- 2 Paper-separating roller assembly.
- 3 Coil spring
- 4 Bracket
- 5 Collar

Note

- Never touch the surface of the paper-separating roller or allow it to become contaminated with chemicals or toner, etc. Any scratching or contamination of the paper-separating roller will affect paper feeding.
- When installing a paper-separating roller assembly, make sure that the paper-separating roller assembly fits up against the left side of the bracket, and then install the collar. At that time, make sure that the space between the paper-separating roller assembly and the bracket is between 0.5 and 1 mm, as shown in the illustration. After installing the paper take-up roller, make sure that the it fits against the front paper separator guide.
- Be sure to install the coil spring as shown in the illustration.

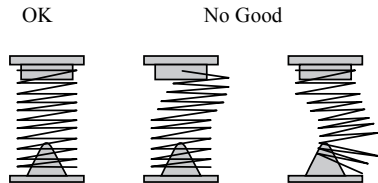
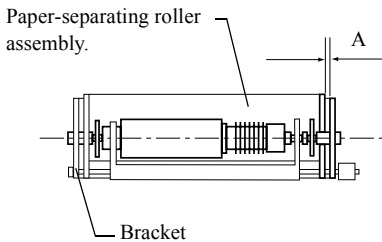

6. Remove the guide.
7. Remove the paper-separating roller (1 E-clip).

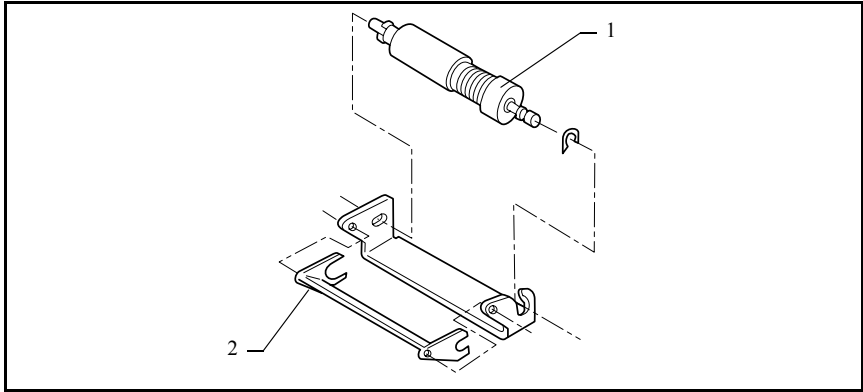

- 1 Paper-separating roller assembly.
- 2 Guide

Note

- *Never touch the surface of the paper-separating roller or allow it to become contaminated with chemicals or toner, etc. Any scratching or contamination of the paper-separating roller will affect paper feeding.*
- *Be sure to install the C-clip and the guide as shown in the illustration. At that time, make sure that the shaft of the paper-separating roller assembly firmly fits into the notches of the guide.*

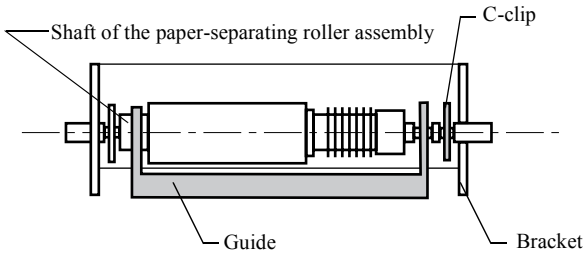

8. Remove the stopper.
9. Remove the bushing.
10. Remove the paper take-up roller drive shaft from the frame of the cassette.
11. Remove the stopper.
12. Remove the paper take-up roller.

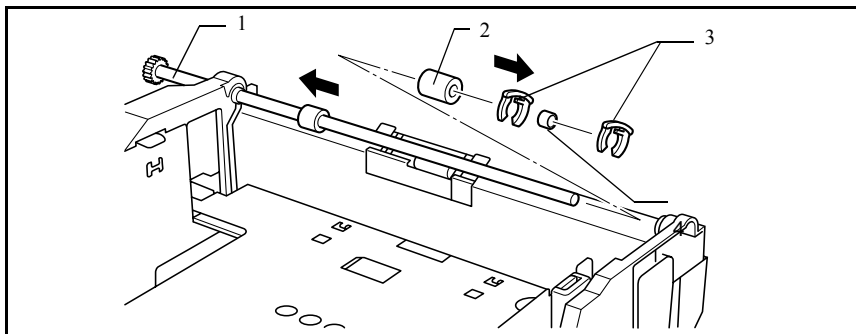

- 1 Paper take-up roller drive shaft
- 2 Paper take-up roller
- 3 Stopper
- 4 Bushing

Note

- *Never touch the surface of the paper take-up roller or allow it to become contaminated with chemicals or toner, etc. Any scratching or contamination of the paper take-up roller will affect paper feeding.*
- *When installing a paper take-up roller, make sure that the projection on the drum fits into the notch in the paper take-up roller, and that the roller is secured with the stoppers.*

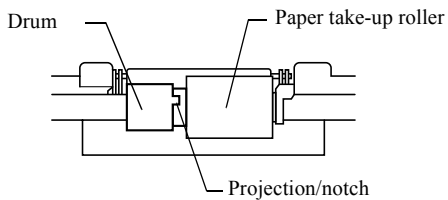

(14) Replacing the heater (H1), thermostat (TS1), thermal fuse (TF1), thermistor 1 (TH1), and heat roller

1. Remove the drive gear assembly (1 E-clip and 1 tension coil spring).
2. Remove the rear (left) cover (1 screw and 2 shoulder screws).

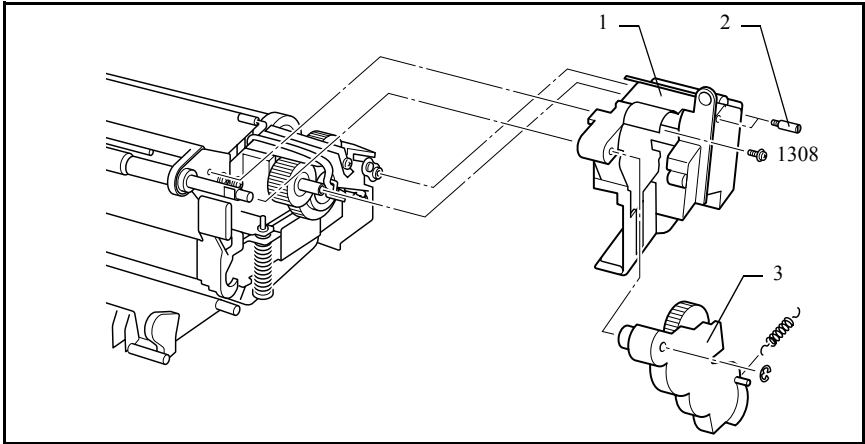

- 1 Rear (left) cover
- 2 Shoulder screw
- 3 Drive gear assembly.

3. Remove the switching guide assembly (1 torsion coil spring).
4. Remove the connector cover (1 screw).

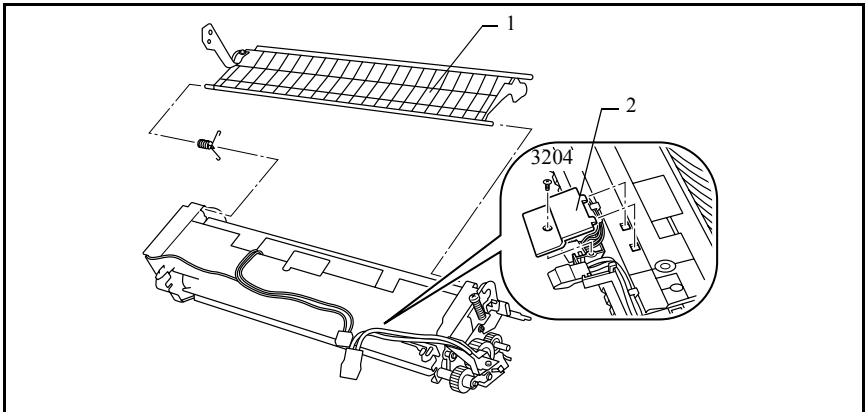

- 1 Switching guide assembly.
- 2 Connector cover

Note

- When installing the rear (left) cover, make sure that the tabs on the cover securely hook onto the frame of the fusing unit.
-

5. Peel off the seal.
6. Remove the front cover (3 screws and 1 connector).
7. Remove the screws securing the thermistor assembly (2 screws), and then turn over the thermistor assembly.
8. Remove the screws securing the cable to the heater (H1) (2 screws).

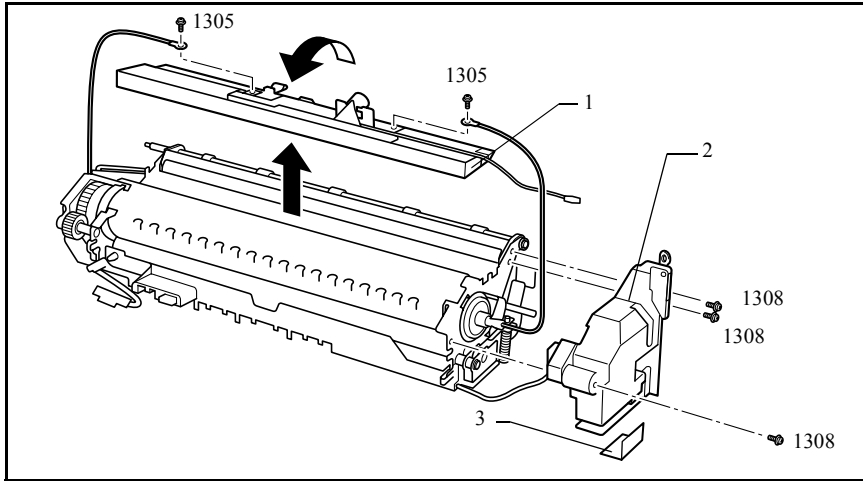

- 1 Thermistor assembly
- 2 Front cover
- 3 Seal

Note

- When installing the front cover, make sure that the harness of the thermistor assembly is not pinched between the front cover and the frame of the fusing unit.
-

9. Remove the thermal fuse (TF1) (2 screws).
10. Remove the thermostat (TS1) (2 screws).
11. Remove the thermistor 1 (TH1) (1 screw).

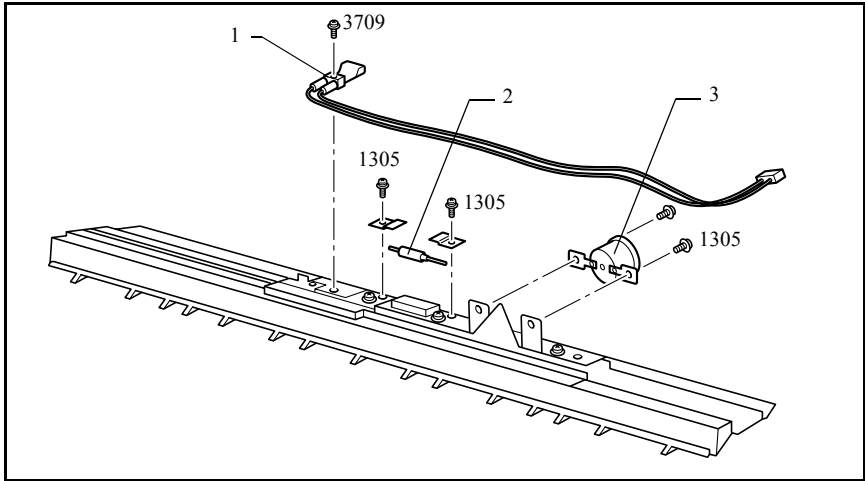

- 1 Thermistor 1 (TH1)
- 2 Thermal fuse (TF1)
- 3 Thermostat (TS1)

Note

- *When installing the front cover, make sure that the tabs on the cover securely hook onto the frame of the fusing unit.*
-

12. Remove the screw securing the heater (H1) (1 screw).
13. Remove the heater holding bracket (1 screw).
14. Pull out the heater (2 screws).

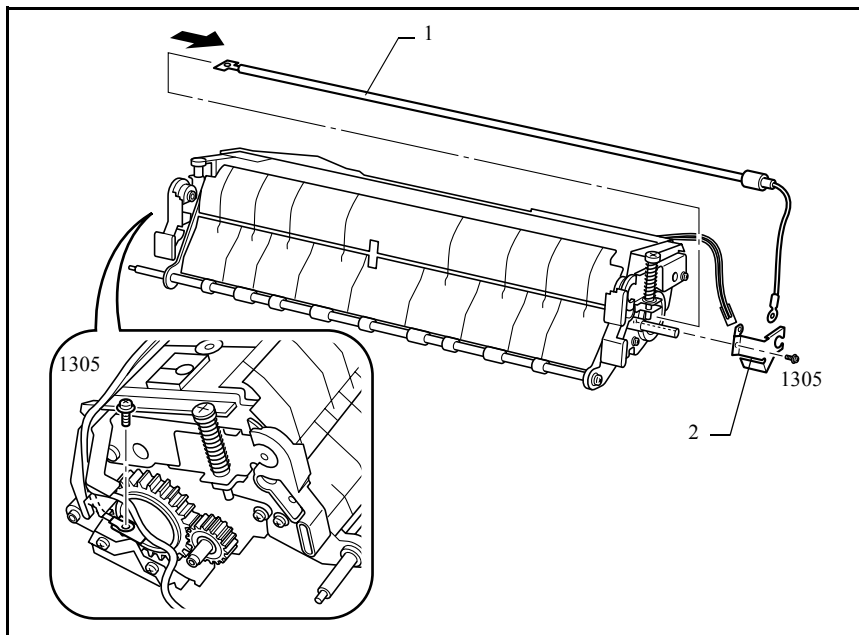

- 1 Heater (H1)
- 2 Heater holding bracket

Note

- *When handling the heater (H1), touch only the ceramic ends of the heater.*
 - *Do not touch the surface of the heater (H1) with your hands.*
-

15. Remove the idler gear (1 E-clip).
16. Remove the heater holder (1 screw).
17. Remove the docking gear (1 E-clip).

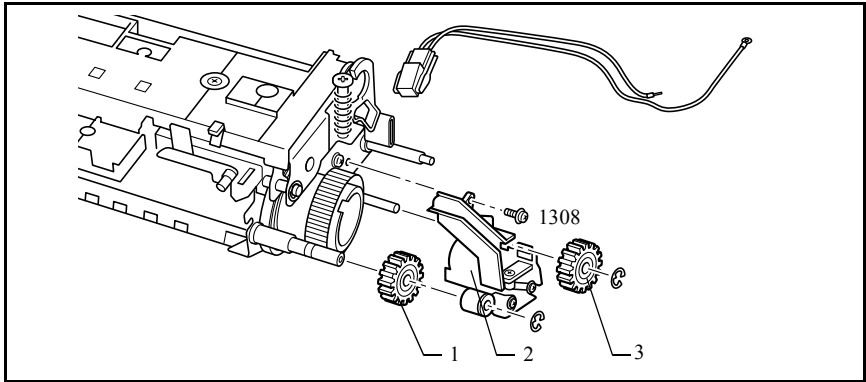

- 1 Docking gear
- 2 Heater holder
- 3 Idler gear

18. Remove the pressure springs (front and rear) (pressure shoulder springs with 1 washer each).
19. Remove the pressure lever assembly (front and rear) (1 E-clip each and 1 bearing each).

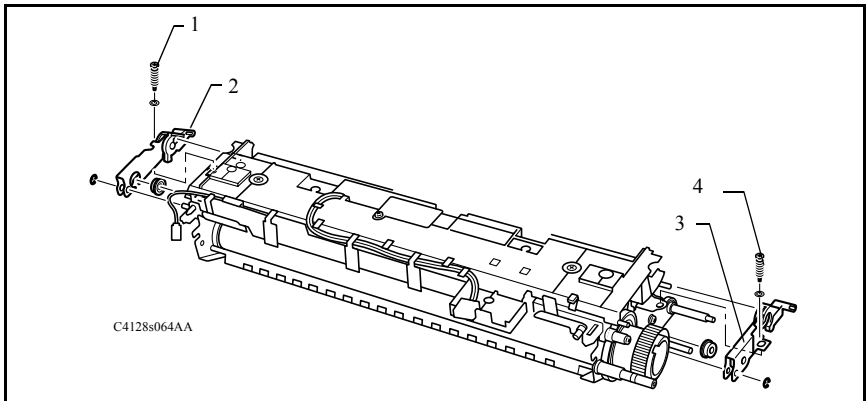

- 1 Pressure spring (front)
- 2 Pressure lever assembly (front)
- 3 Pressure lever assembly (rear)
- 4 Pressure spring (rear)

20. Remove the rear movable guide (2 shoulder screws).

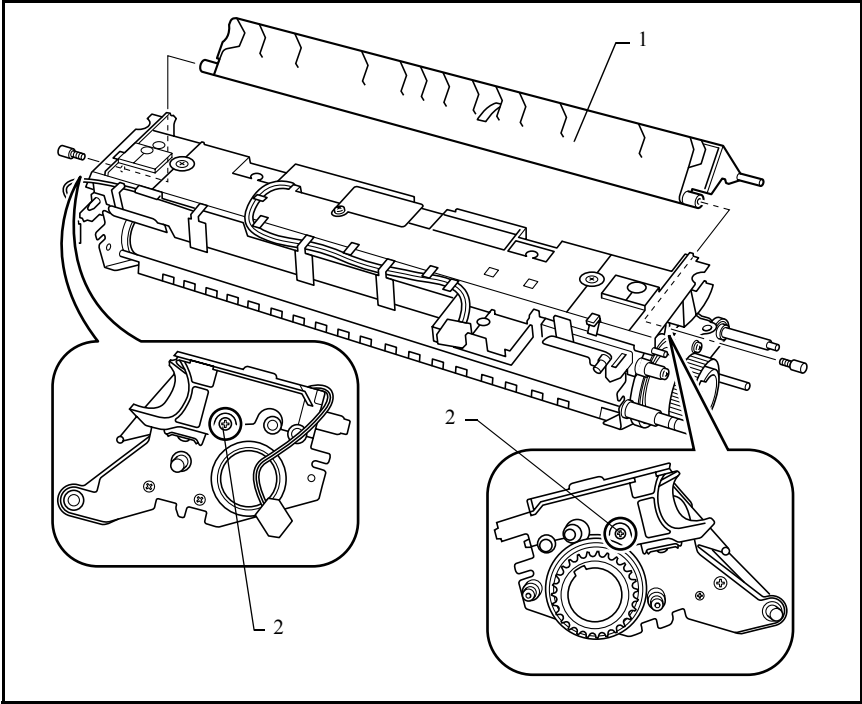

- 1 Rear movable guide
- 2 Shoulder screw

21. Remove the paper output roller (2 E-clips and 2 bushings).
22. Open the thermal insulating plate.
23. Remove the cover (3 screws).
24. Remove the paper output guide assembly (1 screw).

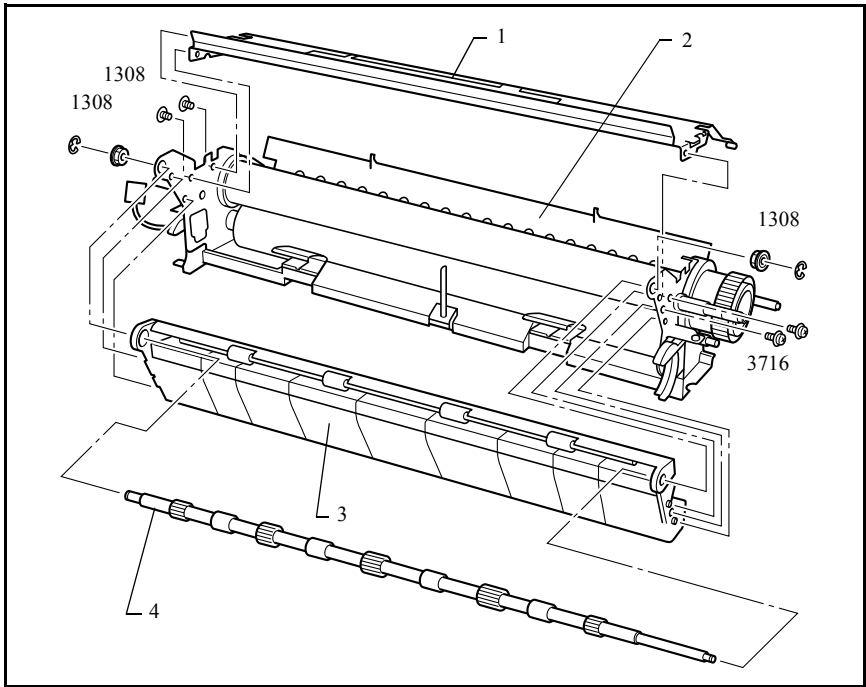

- 1 Cover
- 2 Thermal insulating plate
- 3 Paper output guide assembly
- 4 Paper output roller

25. Remove the heat roller (1 heat roller stop ring, 1 bushing, 1 bearing, 1 insulating material, and 1 thermal insulating plate).
26. Remove the compression roller.

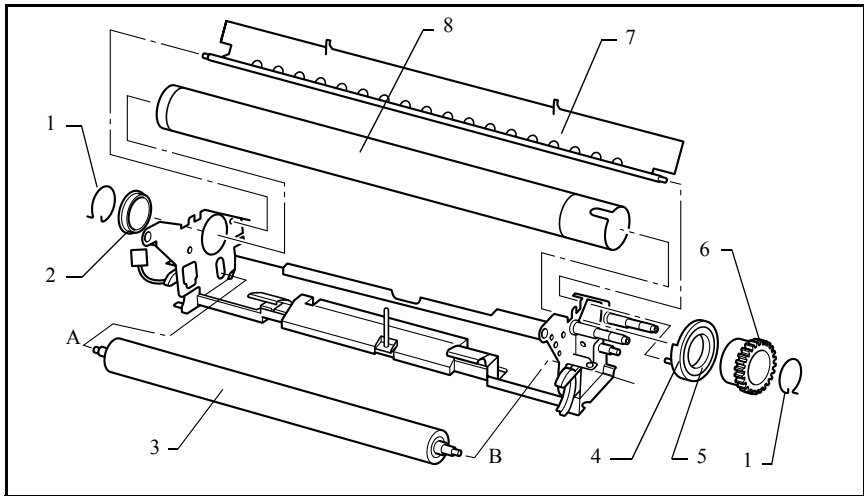

- 1 Heat roller stop ring
- 2 Bushing
- 3 Compression roller
- 4 Insulating bushing
- 5 Bearing
- 6 Heat roller gear
- 7 Thermal insulating plate
- 8 Heat roller

Note

- When handling the heat roller and the compression roller, touch only the ends of the rollers or the roller shafts. Do not touch the surface of the rollers with your hands.
- Never allow the surfaces of the heat roller and compression roller to become scratched or contaminated with chemicals or toner, etc. Any scratching or contamination of the rollers will affect printing quality.
- When installing a compression roller, first insert end A of the compression roller shaft into the frame of the fusing unit, and then insert end B of the shaft.

(15) Replacing the paper output sensor (PC3) of the fusing section

1. Remove the rear cover of the fusing unit (1 screw and 1 shoulder screw).
2. Remove the sensor stopper.
3. Remove the paper output sensor cover (1 screw).
4. Remove the paper output sensor (PC3) (1 sensor stopper).

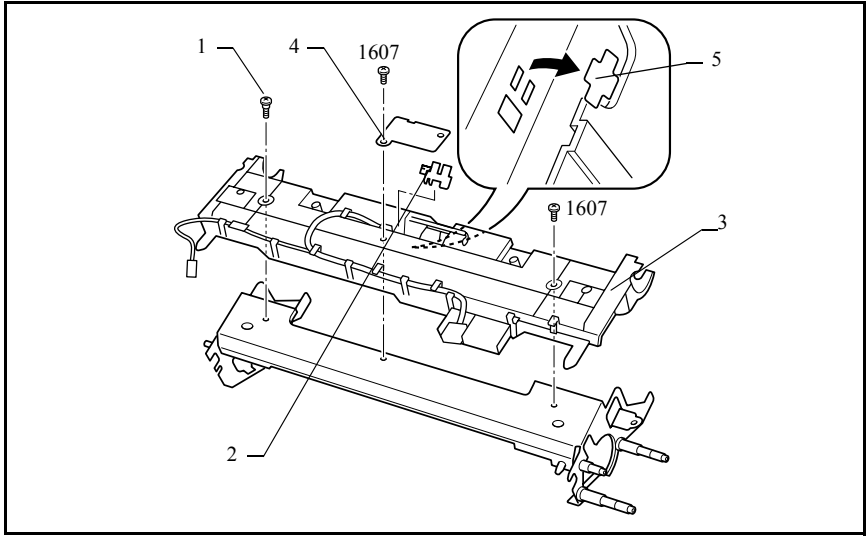

- 1 Shoulder screw
- 2 Paper output sensor (PC3)
- 3 Rear cover of the fusing unit
- 4 Paper output sensor cover
- 5 Sensor stopper

Note

- When installing a paper output sensor (PC3), be sure to affix the sensor stopper.
 - When affixing the sensor stopper, make sure that it will not peel off or move out of place.
-

(16) Replacing the image transfer roller unit

1. Raise the guides on the two ends of the image transfer roller.
2. Hold the two guides, and remove the image transfer roller unit.

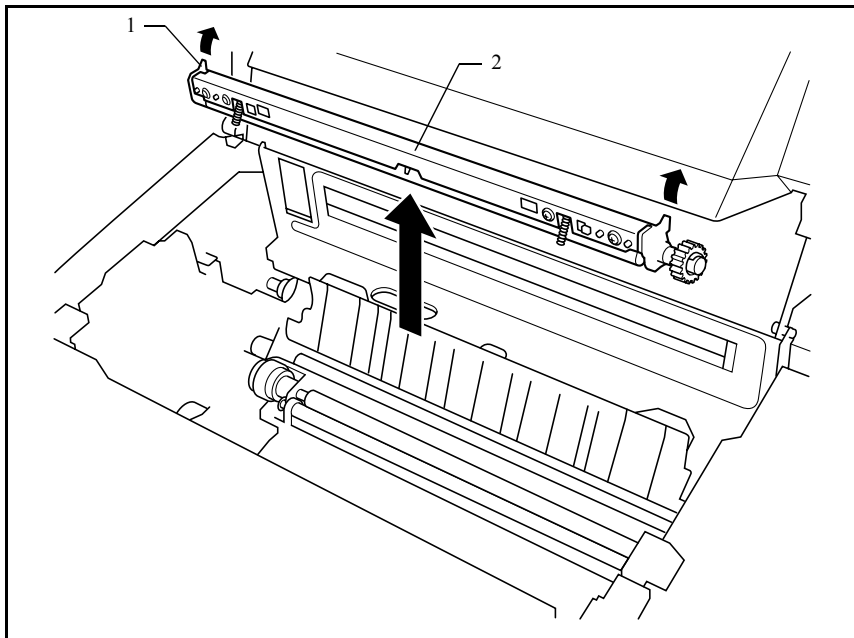

- 1 Image transfer roller guides
- 2 Image transfer roller unit

Note

- *Never touch the surface of the image transfer roller or allow it to become contaminated with chemicals or toner, etc. Any scratching or contamination of the image transfer roller will affect paper feeding.*
 - *When handling the image transfer roller unit, only touch the roller shaft, the bushings or the image transfer roller guide.*
-

(17) Replacing the new-imaging-cartridge detection board (PWB-D)

1. Remove the PWB-D assembly (2 shoulder screws, 2 compression coil springs and 1 connector).
2. Remove the new-imaging-cartridge detection board (PWB-D) (1 holding bracket, 1 screw and 1 connector).

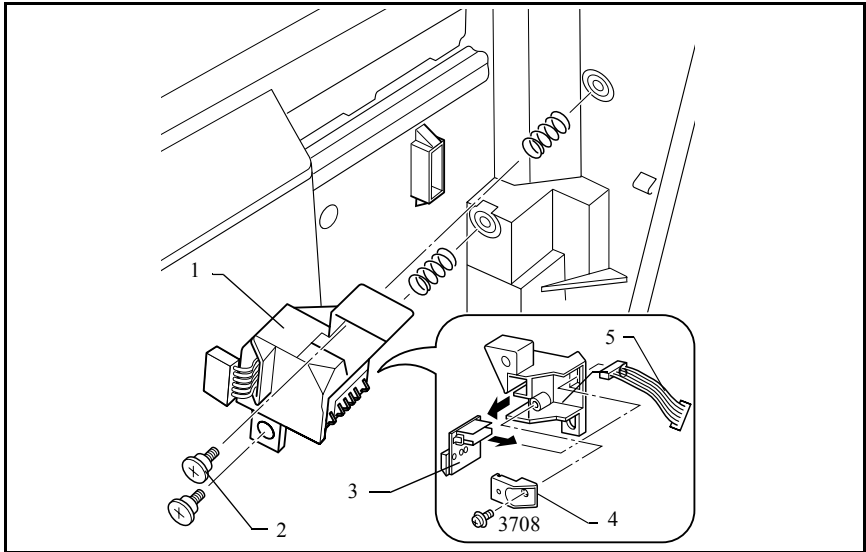

- 1 PWB-D assembly.
- 2 Shoulder screw
- 3 New-imaging-cartridge detection board (PWB-D)
- 4 Holding bracket
- 5 Relay harness
- 6 New-imaging-cartridge detection board cover

Note

- *When installing a PWB-D assembly, be sure to store the relay harness behind the new-imaging-cartridge detection board cover. If too much of the harness is outside of the cover, it may obstruct the operation of the PWB-D assembly, possibly resulting in a malfunction.*

Correct

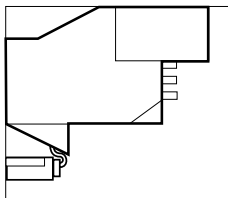

Incorrect

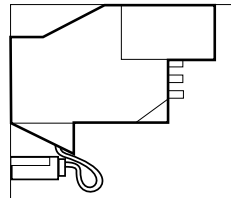

(18) Removing the outer covers

1. Remove the right cover (4 screws).
2. Remove the top front cover (3 screws and 1 connector).

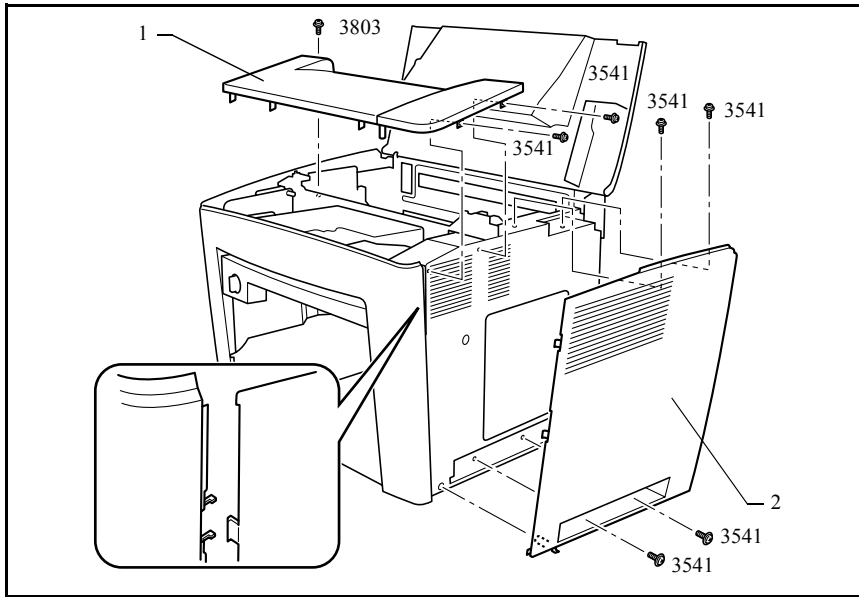

- 1 Top front cover
- 2 Right cover

Note

- *When installing the covers, be sure to first insert the tabs on the cover into the printer frame before putting the cover back into place.*
-

3. Remove the rear cover (8 screws).
4. Remove the left cover (4 screws).
5. Remove the front cover (2 screws).

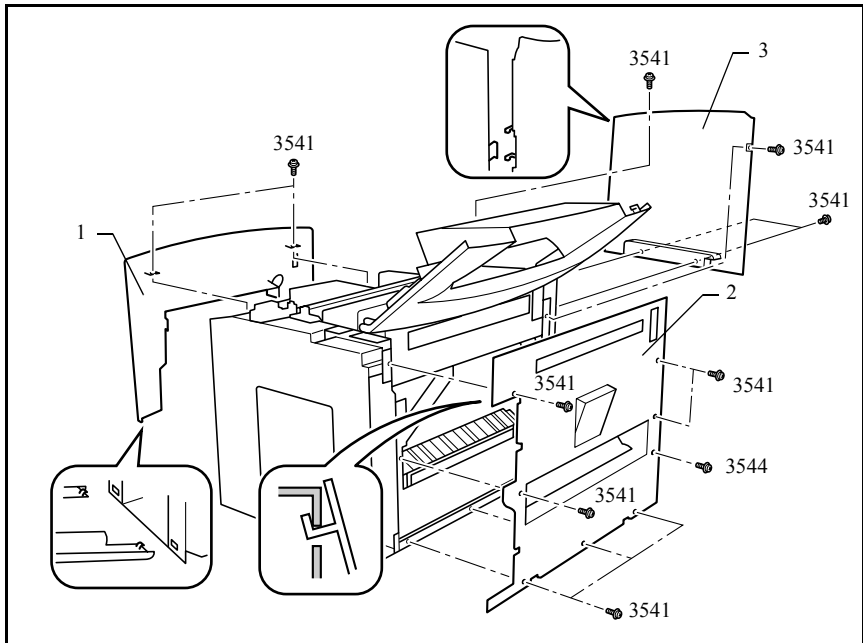

- 1 Front cover
- 2 Rear cover
- 3 Left cover

Note

- *When installing the covers, be sure to first insert the tabs on the cover into the printer frame before putting the cover back into place.*

(19) Replacing the control panel

1. Remove the control panel (2 screws).

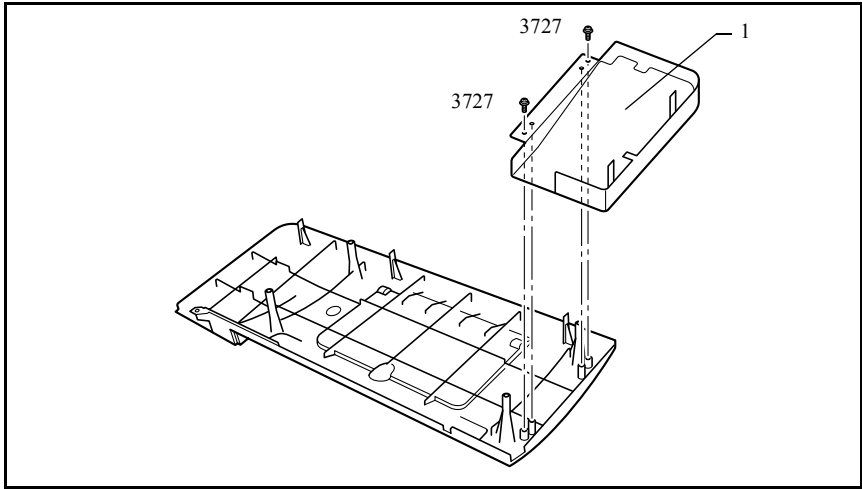

1 Control panel

(20) Removing the shield

1. Remove the shield (16 screws).

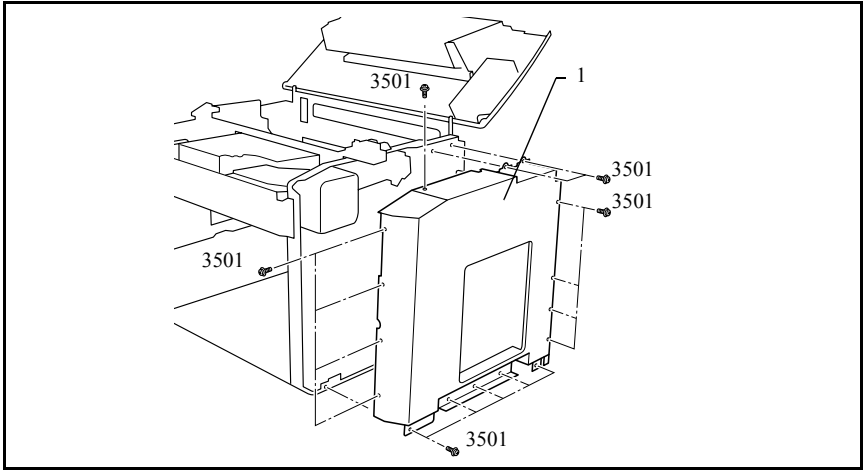

1 Shield

Note

- When installing the shield, be sure to first insert the positioning hooks on the shield into the slots in the frame.

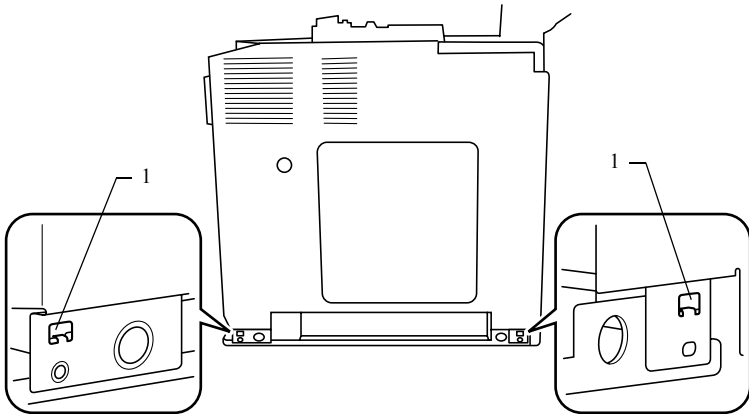

1 Positioning hooks on the shield

(21) Replacing thermistor 2 (TH2)

1. Remove thermistor 2 (TH2) (1 screw and 1 connector).

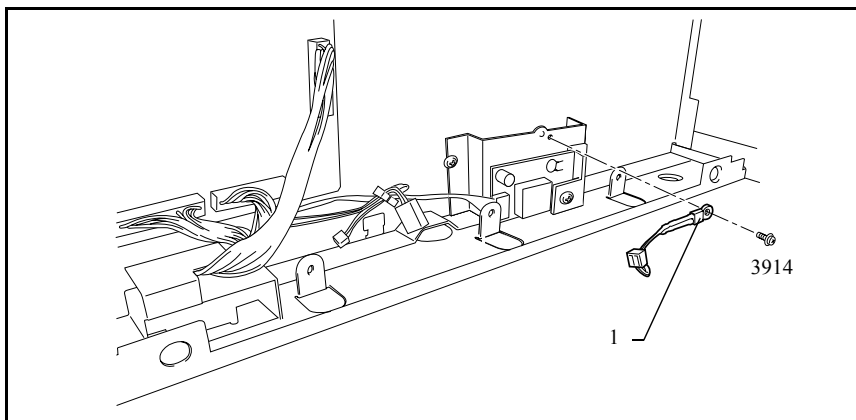

- 1 Thermistor 2

(22) Replacing the humidity sensor (HS1)

1. Remove the mounting screw securing the humidity sensor (HS1) and the sensor holder (1 screw).
2. Remove the humidity sensor (HS1) from the sensor holder.

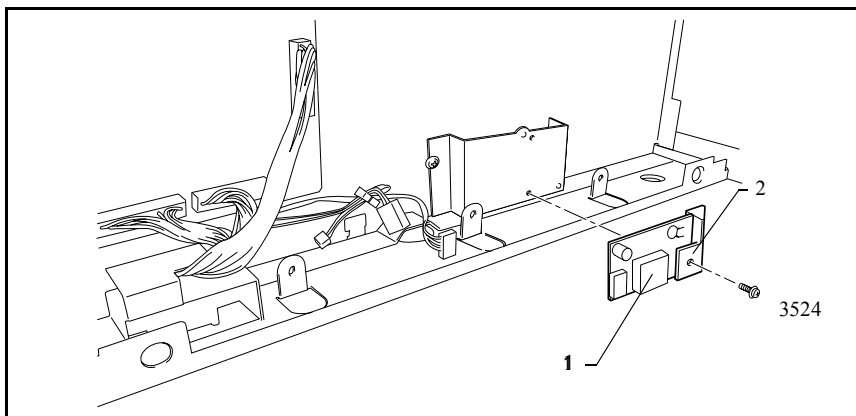

- 1 Humidity sensor (HS1)
- 2 Sensor holder

(23) Replacing the power supply unit fan motor

1. Open the wire holder, and remove the wires (1 wire holder).
2. Remove the power supply unit fan motor (M4) (2 screws and 1 connector).

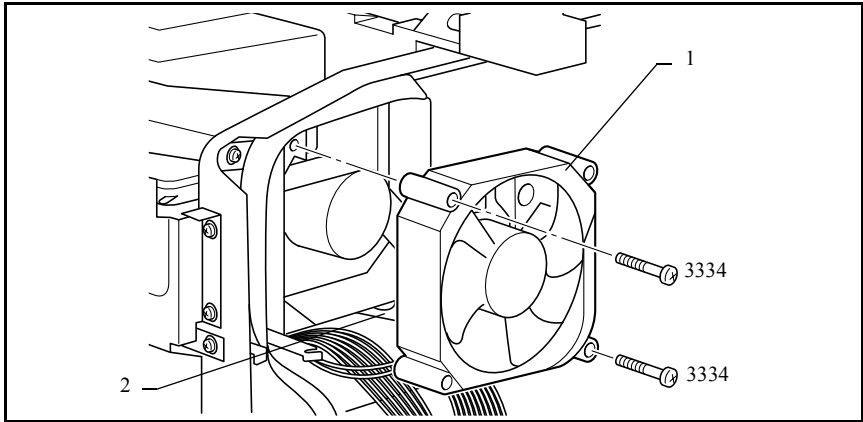

- 1 Power supply unit fan motor (M4)
2 Wire holder

Note

- *When installing a power supply unit fan motor (M4), be sure to install it as shown in the illustration (with the manufacturer's name plate towards the printer).*

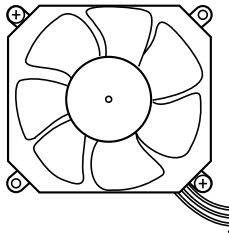

(24) Replacing interlock switch 1 (S2)

1. Open the wire holders, and remove the wires (2 wire holders).
2. Remove the flexible wires from the wire guides on the interlock switch 1 assembly (3 guides).
3. Remove the interlock switch 1 assembly (2 screws and 3 connectors).

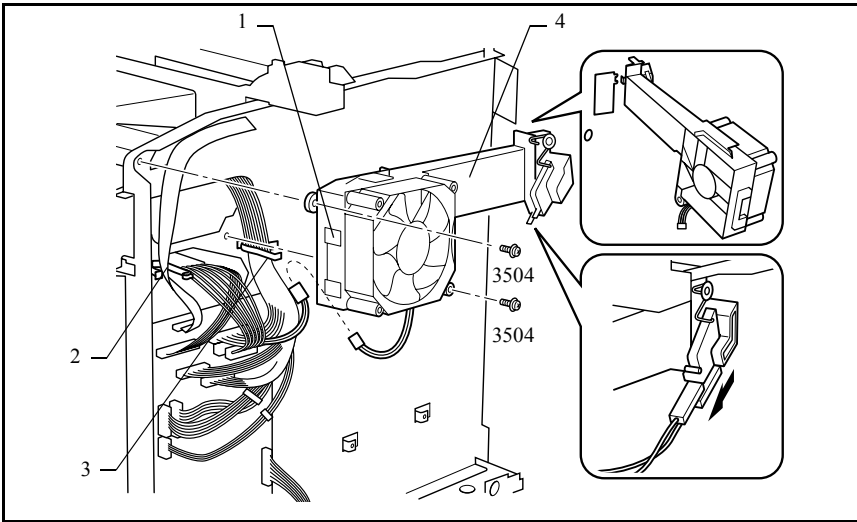

- 1 Wire guide
- 2 Wire holder
- 3 Wire holder
- 4 Interlock switch 1 assembly

4. Remove interlock switch 1 (S2) (1 screw and 1 torsion coil spring).

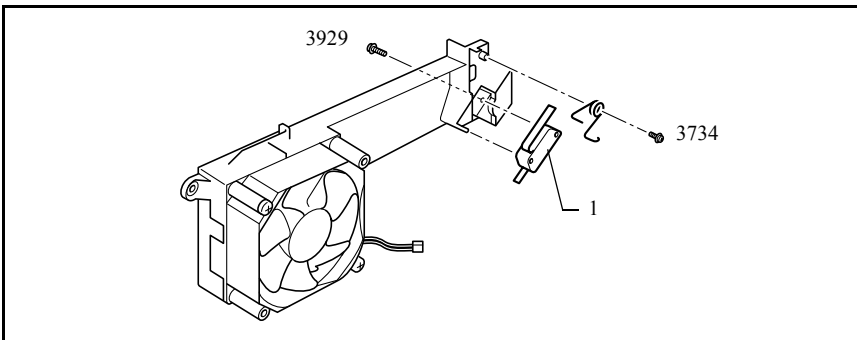

- 1 Interlock switch 1 (S2)

(25) Replacing the main control board (PWB-A)

1. Remove the main control board (PWB-A) (4 screws, 18 connectors, and 1 card cable).

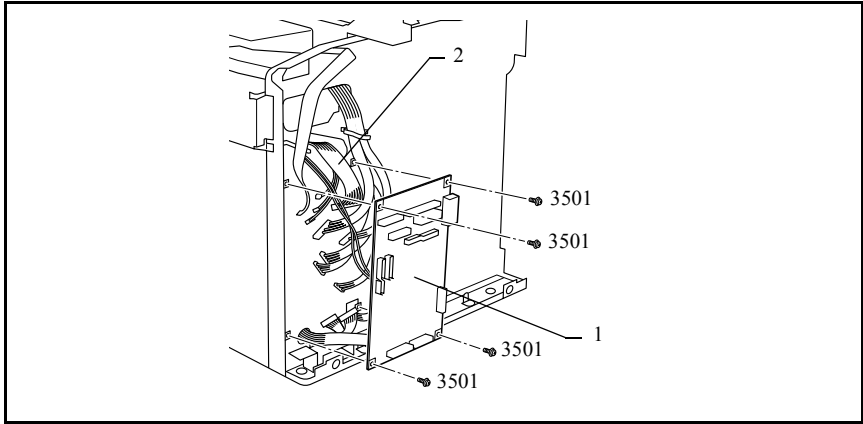

- 1 Main control board (PWB-A)
- 2 Card cable

Note

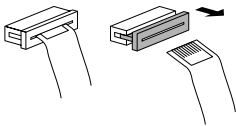

- When disconnecting the card cable, first release the connector lock, and then pull out the cable.

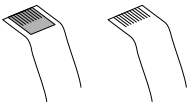

- When connecting the card cable, insert it with the pins facing upwards.

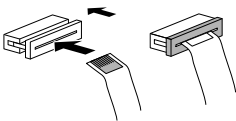

- When connecting the card cable, insert the cable, and then lock the connector.

Note

- When disconnecting the connectors attached to the main control board (PWB-A), be careful not to pull out the expansion cassette connectors shown in the illustration.
- The expansion cassette connectors, shown in the illustration, are not the type that can be pulled up. If they are pulled with excessive force, they may be damaged. To disconnect the expansion cassette connectors, remove the drawer connecting assembly from the base plate, and then remove the expansion cassette harness assembly from the drawer connecting assembly.

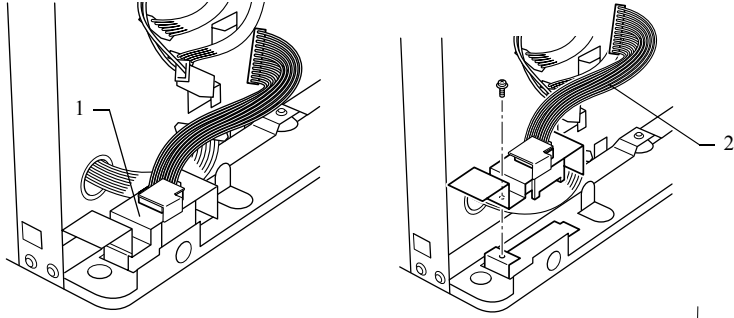

- 1 Drawer connecting assembly
- 2 Harness assembly

(26) Replacing the print head unit



WARNING



Do not replace the print head unit with the printer turned on. Exposure to the laser beam may result in blindness.



The print head unit must not be disassembled or adjusted. Exposure to the laser beam may result in blindness.

1. Make sure that the power cord is unplugged.
2. Remove the lock lever (3 screws and 1 tension coil spring).
3. Remove the print head unit (1 screw, 2 shoulder screws, 2 coil springs and 1 connector).

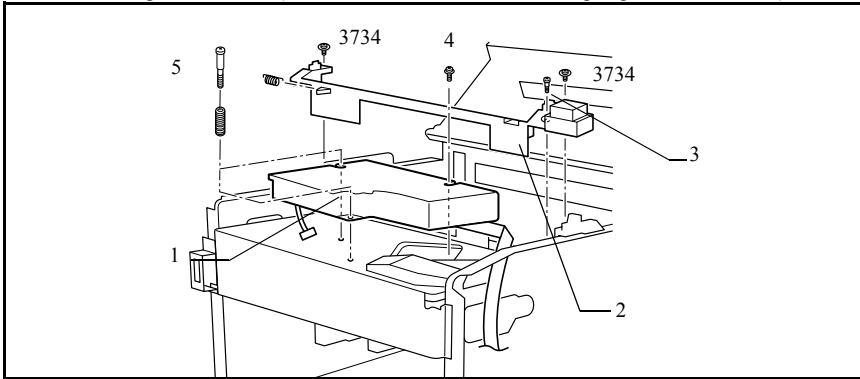

- 1 Print head unit
- 2 Lock lever
- 3 Shoulder screw
- 4 Print head unit mounting screws (special screws)
- 5 Print head unit mounting shoulder screws (special screws)

Note

- *When installing a print head unit, make sure that the positioning pins on the print head unit fit into the positioning holes in the frame.*

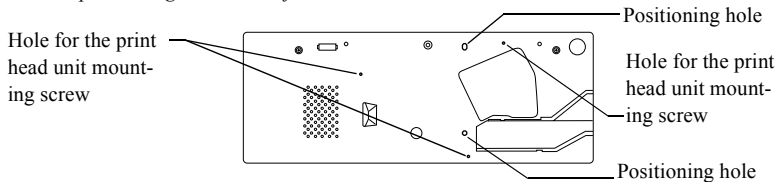

- *When installing a print head unit, do not touch the top surface of the print head unit or the lens of the laser emission section.*

(27) Replacing the ozone fan motor (M6)

1. Open the wire holder, and remove the wires (1 wire holder).
2. Remove the ozone fan motor (2 screws and 1 connector).

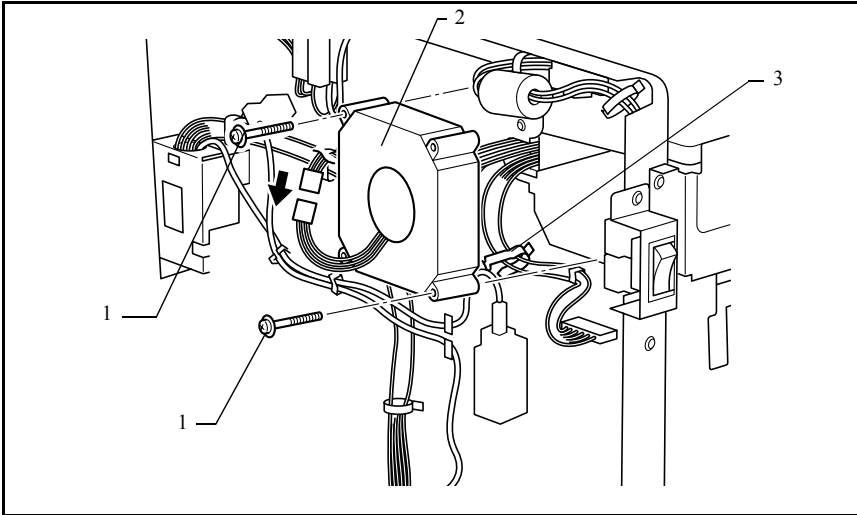

- 1 Mounting screw
- 2 Ozone fan motor (M6)
- 3 Wire holder

Note

- When installing an ozone fan motor (M6), be sure to position the cord as shown in the illustration.

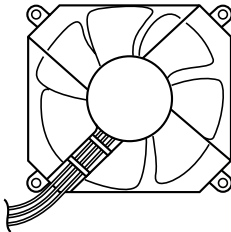

(28) Replacing the power supply board (PU1)

1. Remove the shield (7 screws).
2. Open the wire holders, and remove the wires (3 wire holders).
3. Remove the power supply assembly (3 screws and 1 connector).

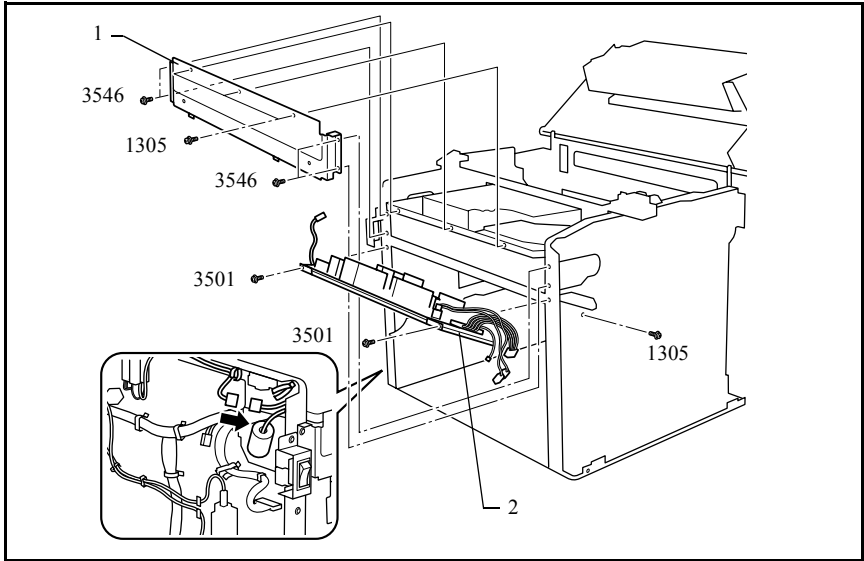

- 1 Shield
- 2 Power supply assembly.

4. Remove the power supply board (PU1) (3 screws, 3 connectors, and 2 wire holders).

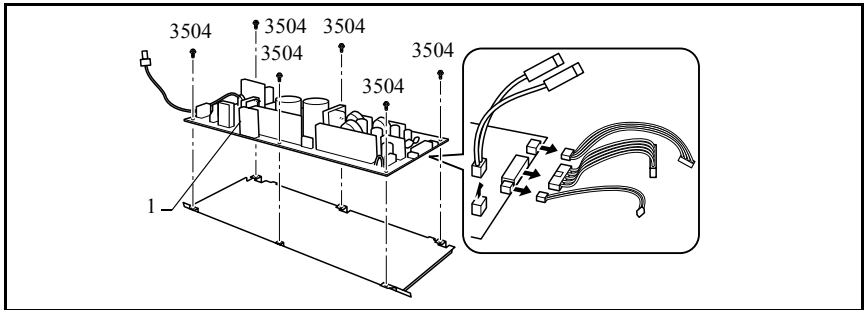

- 1 Power supply board (PU1)

Note

- When installing the shield, be sure to first insert the positioning hooks on the shield into the slots in the frame.

(29) Replacing the high voltage unit (HV1)

1. Open the wire holders, and remove the wires (2 wire holders).
2. Remove the high voltage unit (HV1) (3 screws and 3 connectors).
3. Remove the protective plate.

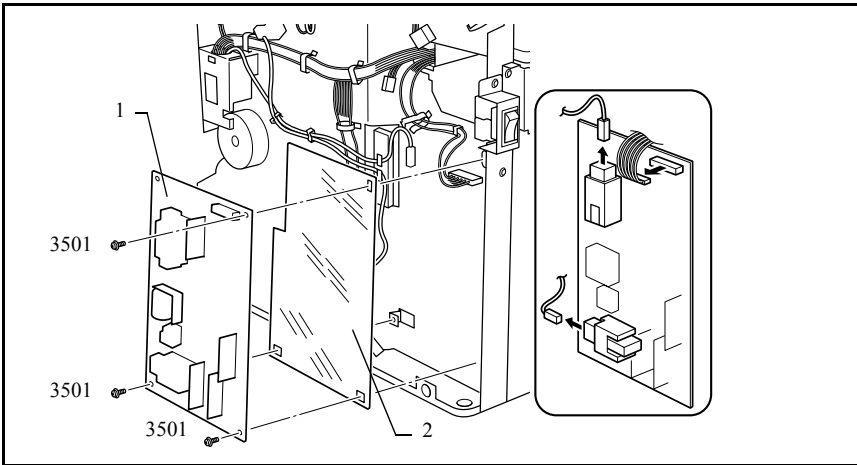

1 High voltage unit (HV1)

2 Protective plate

Note

- When installing a high voltage unit (HV1), be sure to install the protective plate.

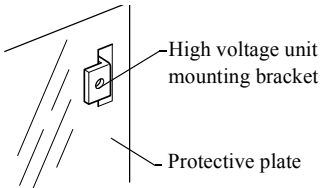

- When installing the protective plate, make sure that the high voltage unit mounting bracket fits into the slot in the protective plate.

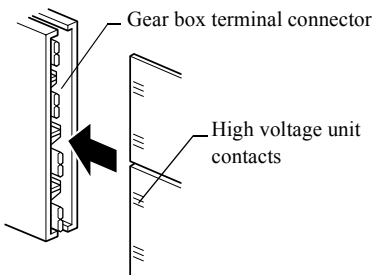

- When installing the high voltage unit, make sure that the high voltage unit contacts are correctly aligned with the gear box terminal connectors.

(30) Replacing the power switch (S1)

1. Remove the primary harness cover (2 screws).
2. Remove the power switch (S1) (4 connectors).

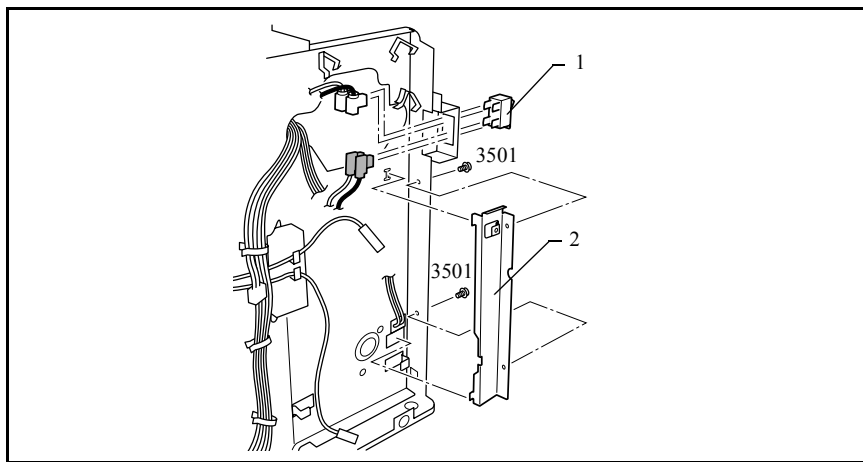

- 1 Power switch (S1)
- 2 Primary harness cover

Note

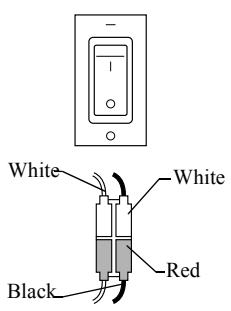

• When installing a power switch (S1), be extremely careful to install it as shown in the illustration.

• When connecting the power switch (S1), be extremely careful to connect the cables as shown in the illustration.

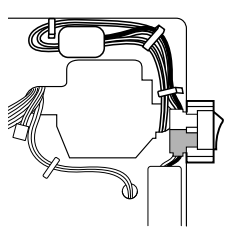

• Clamp the cables of the power switch (S1) in the cable holders as shown.

(31) Replacing interlock switch 2 (S3)

1. Remove the switch cover.
2. Open the wire holders, and remove the wires (2 wire holders).
3. Remove interlock switch 2 (S3) (4 connectors).

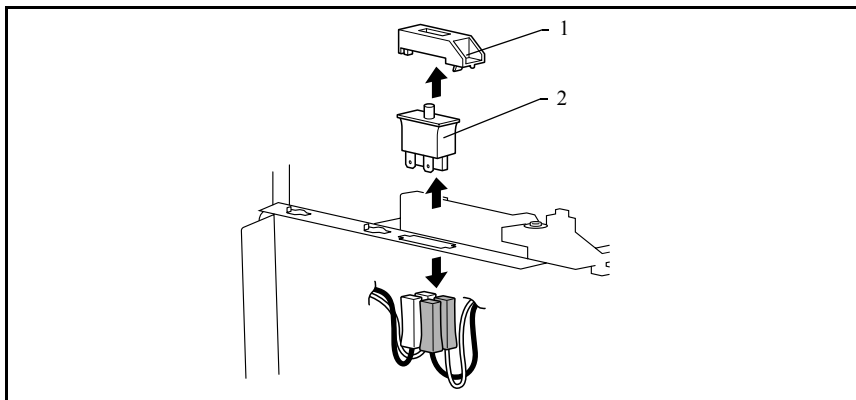

- 1 Primary harness cover
- 2 Interlock switch 2 (S3)

Note

- When connecting interlock switch 2 (S3), be extremely careful to connect the cables as shown in the illustration.

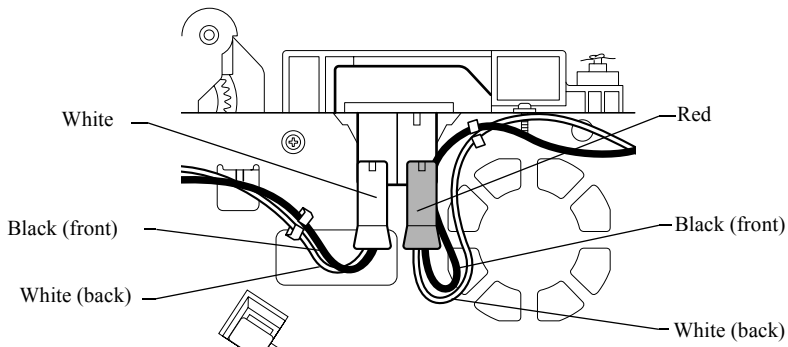

(32) Replacing the main motor (M1) and imaging cartridge drive motor (M2)

1. Open the wire holders, and remove the wires (1 wire holder each).
2. Remove the main motor (M1) and imaging cartridge drive motor (M2) (4 screws each).

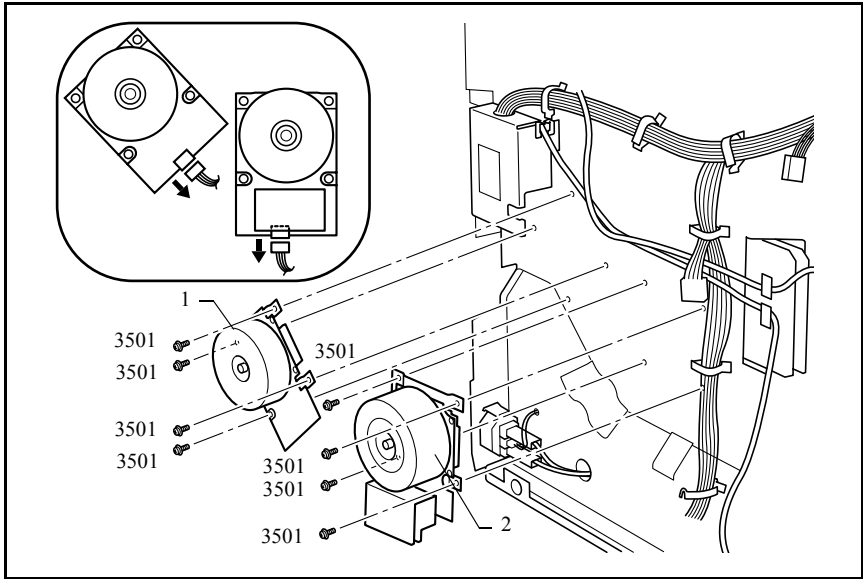

- 1 Main motor (M1)
- 2 Imaging cartridge drive motor (M2)

(33) Replacing the paper size detection switch (S4), the paper empty sensor (PC6), and the paper take-up clutch (CL2) for the first paper cassette

1. Open the wire holders, and remove the wires (5 wire holders).
2. Disconnect the connectors for the paper take-up clutch (CL2) and the paper size detection switch (S4) for the first paper cassette (2 connectors).
3. Remove the stopper for the paper take-up clutch (CL2) for the first paper cassette (1 stopper).
4. Remove the left rail assembly (4 screws).
5. Remove the paper take-up clutch (CL2) for the first paper cassette (1 bushing and 1 shaft).
6. Remove the paper size detection assembly (1 screw).

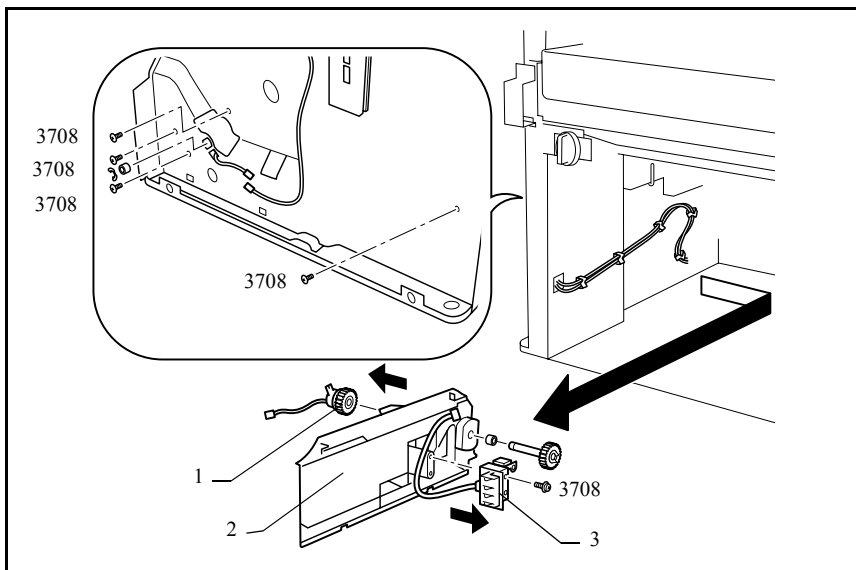

- 1 Paper take-up clutch for the first paper cassette (CL2)
- 2 Left rail assembly.
- 3 Paper size detection assembly.

Note

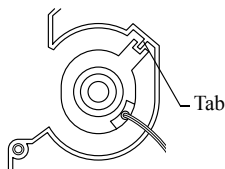

- When installing the paper take-up clutch (CL2) for the first paper cassette, be sure to align the slot in the clutch with the tab on the left rail assembly.

7. Remove the actuator.
8. Remove the sensor stopper.
9. Remove the paper near-empty sensor (PC7) for the first paper cassette.
10. Remove the paper size detection switch (S4) for the first paper cassette.

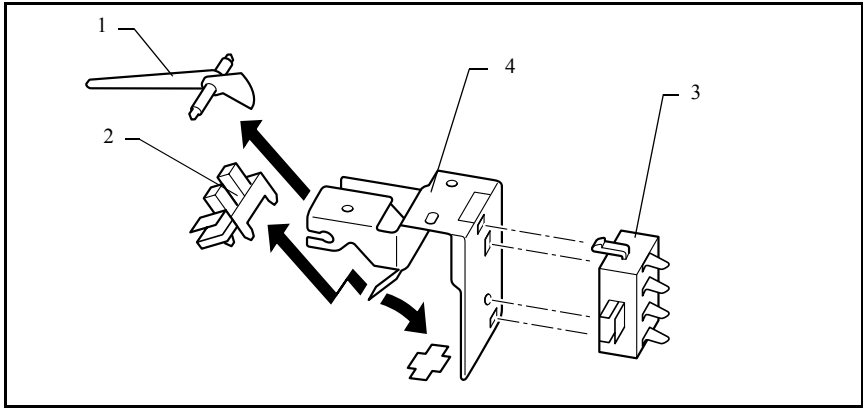

- 1 Actuator
- 2 Paper near-empty sensor for the first paper cassette (PC7)
- 3 Paper size detection switch for the first paper cassette (S4)
- 4 Paper size detection assembly.

Note

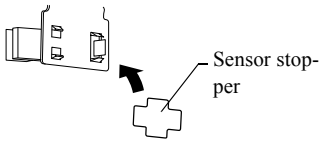

- When installing a paper near-empty sensor (PC7) for the first paper cassette, be sure to affix the sensor stopper. In addition, make sure that the sensor stopper will not peel off or move out of place.

(34) Replacing the fusing fan motor (M3)

1. Open the wire holders, and remove the wires (9 wire holders).
2. Remove the fan motor assembly (4 screws and 4 connectors).
3. Remove the fusing fan motor (M3) (2 screws).

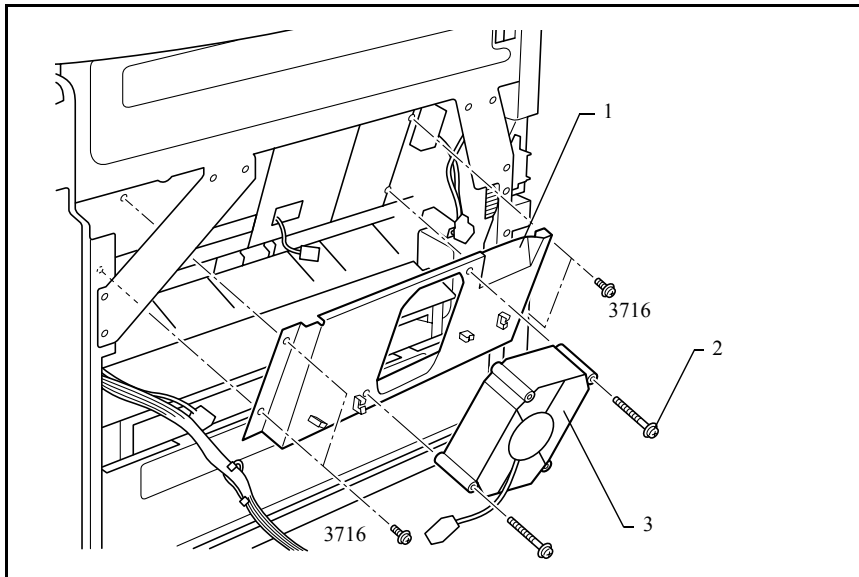

- 1 Fan assembly.
2 Fan securing screw

- 3 Fusing fan motor (M3)

Note

- When connecting the fusing fan motor (M3), be sure to position the cord as shown in the illustration.

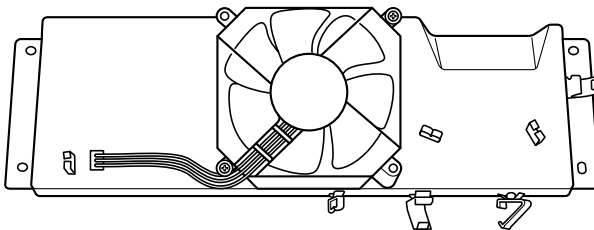

(35) Replacing the transport roller clutch (CL1) and the paper sensor (PC1) of the image transfer section

1. Remove the image transfer unit.
2. Remove the lower transport guide.
3. Remove the transport roller clutch (CL1) (1 E-clip and 1 bushing).

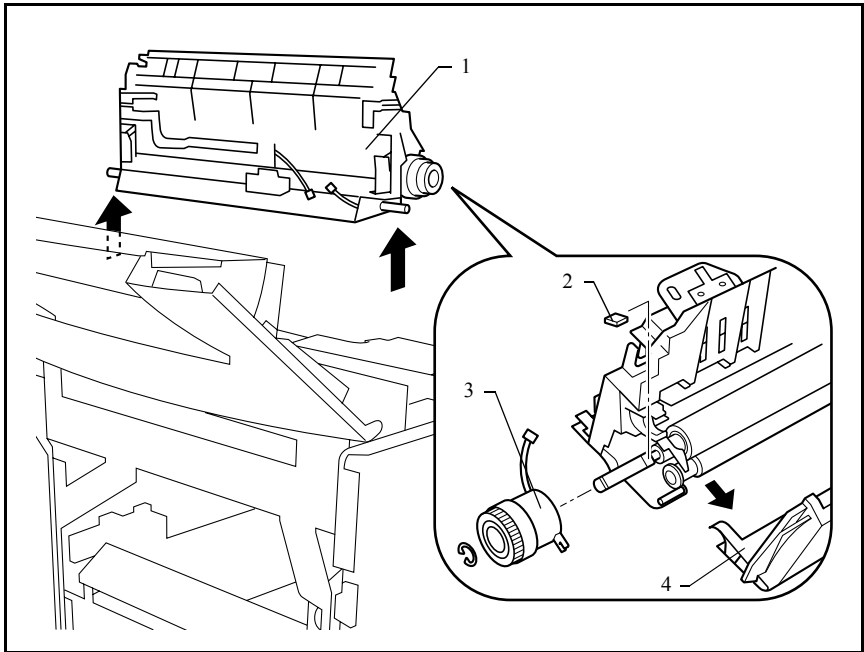

- | | |
|-----------------------|---------------------------------|
| 1 Image transfer unit | 3 Transport roller clutch (CL1) |
| 2 Bushing | 4 Lower transport guide |

Note

- When installing a transport roller clutch (CL1), be sure to install the bushing.

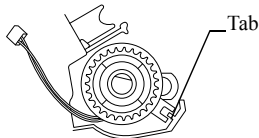

- When installing the transport roller clutch (CL1), be sure to align the slot in the clutch with the tab on the image transfer unit.

4. Remove the sensor assembly (2 screws).
5. Remove the paper sensor (PC1) of the image transfer section (1 sensor stopper).
6. Remove the actuator and the torsion coil spring.

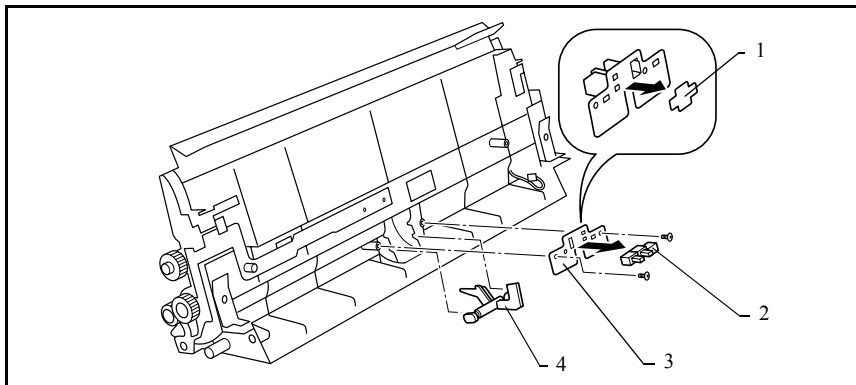

- 1 Sensor stopper
- 2 Paper sensor of the image transfer section (PC1)
- 3 Sensor assembly
- 4 Actuator

Note

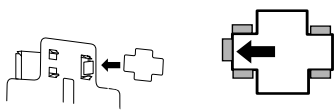

- When installing a paper sensor (PC1) of the image transfer section, be sure to affix the sensor stopper.
- When affixing the sensor stopper, be sure to position it as shown in the illustration. Make sure that the sensor stopper will not peel off or move out of place.

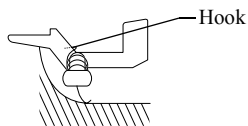

- When installing the actuator, make sure that the hook on the torsion coil spring is attached to it.
- When installing the actuator, make sure that the torsion coil spring is securely attached to the transport unit.

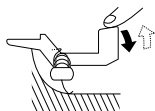

- Turn the actuator with your finger, and check that the spring smoothly returns it into position after you remove your finger.

5-7. Duplex unit disassembly procedures

(1) Replacing the transport motor (M1), the switchback motor (M2), the control board (PWB-A), and the duplex cover switch (PC1)

1. Remove the drive cover (2 screws).
2. Remove the transport motor (M1) (2 screws and 1 connector).
3. Remove the switchback motor (M2) (2 screws and 1 connector).
4. Remove the control board (PWB-A) (2 screws).
5. Remove the duplex cover switch (PC1) (1 sensor stopper).

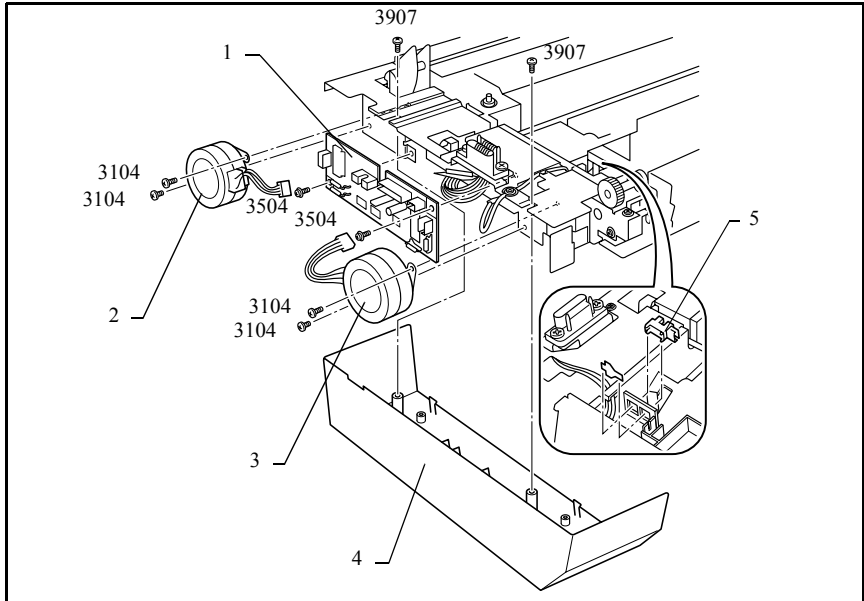

- 1 Control board (PWB-A)
- 2 Switchback motor (M2)
- 3 Transport motor (M2)

- 4 Drive cover
- 5 Duplex cover switch (PC1)

Note

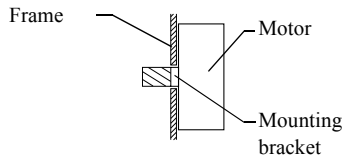

- When installing a motor, make sure that the mounting bracket of the motor securely fits onto the frame of the duplex unit as shown in the illustration.

Note

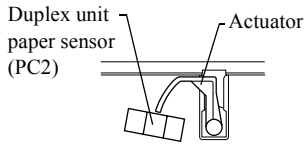

- When installing a control board (PWB-A), make sure that the end of the actuator is positioned at about the center of the duplex unit paper sensor (PC2) on the board.

- When installing a duplex cover sensor (PC1), be sure to affix the sensor stopper.
 - When affixing the sensor stopper, make sure that it will not peel off or move out of place.
-

5-8. 500-sheet lower feed unit disassembly procedures

(1) Replacing the control board (PWB-A)

1. Remove the bracket assembly (3 screws).
2. Remove the control board (PWB-A) (4 screws and 5 connectors).

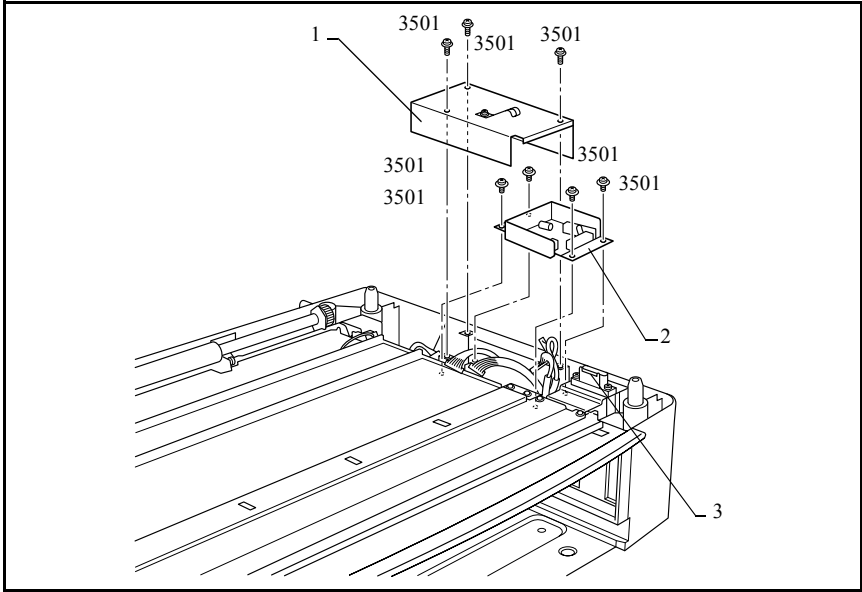

- 1 Bracket assembly.
- 2 Control board (PWB-A)
- 3 Drawer connector

Note

- When installing a control board (PWB-A), make sure that connector PJI on the board is near the drawer connector.

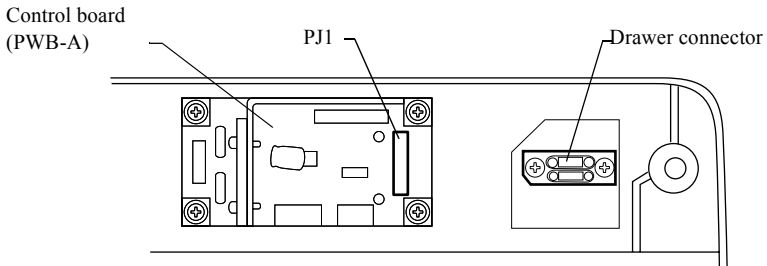

(2) Replacing the paper take-up clutch (CL1) and the paper take-up motor (M1)

1. Remove the paper take-up assembly (6 screws).
2. Remove the motor assembly (5 screws, 2 E-clips, 1 bushing, and 1 gear).
3. Remove the paper take-up clutch (CL1) (1 E-clip).
4. Remove the paper take-up motor (M1) (2 screws).

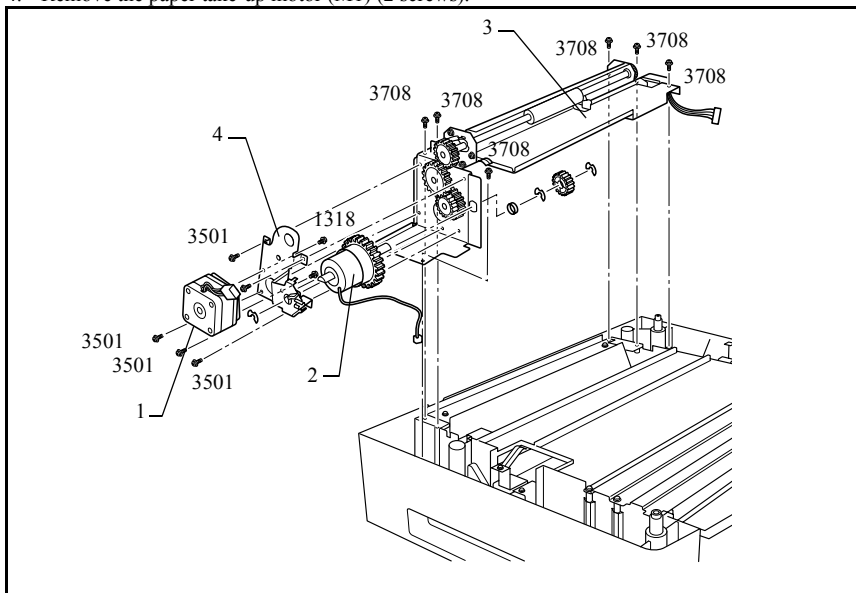

- 1 Motor assembly
- 2 Paper take-up clutch (CL1)
- 3 Paper take-up assembly
- 4 Paper take-up motor (M1)

Note

- When installing a paper take-up motor (M1), be sure to position the cord as shown in the illustration.

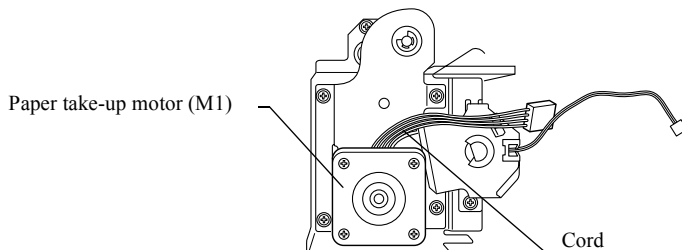

(3) Replacing the paper sensor (PC1)

1. Remove the switch cover (1 screw).
2. Remove the paper sensor (PC1) (1 sensor stopper and 1 connector).

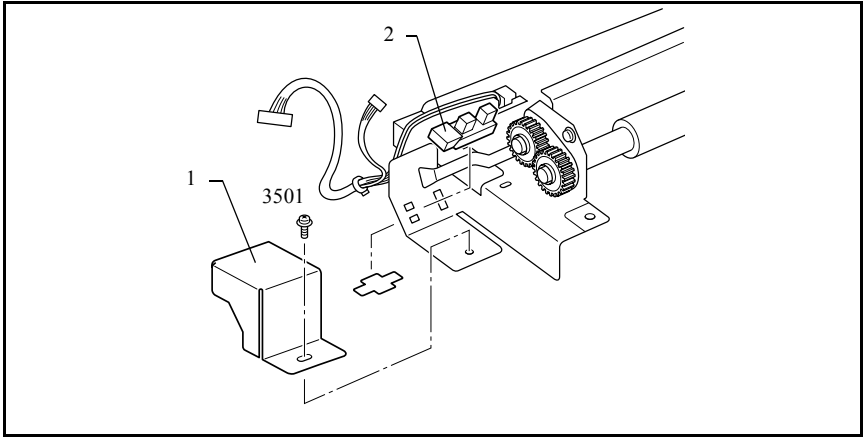

- 1 Switch cover
- 2 Paper sensor (PC1)

Note

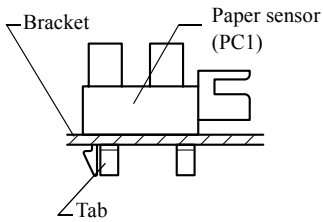

- When installing the paper sensor (PC1), make sure that the tab of the detection switch extends from the top of the bracket.
- When installing a paper sensor (PC1), be sure to affix the sensor stopper.

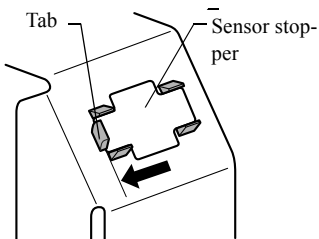

- When affixing the sensor stopper, be sure to position it as shown in the illustration. Make sure that the sensor stopper will not peel off or move out of place.

(4) Replacing the paper empty sensor (PC2)

1. Remove the sensor cover (2 screws).
2. Remove the paper empty sensor (PC2) (1 screw and 1 connector).

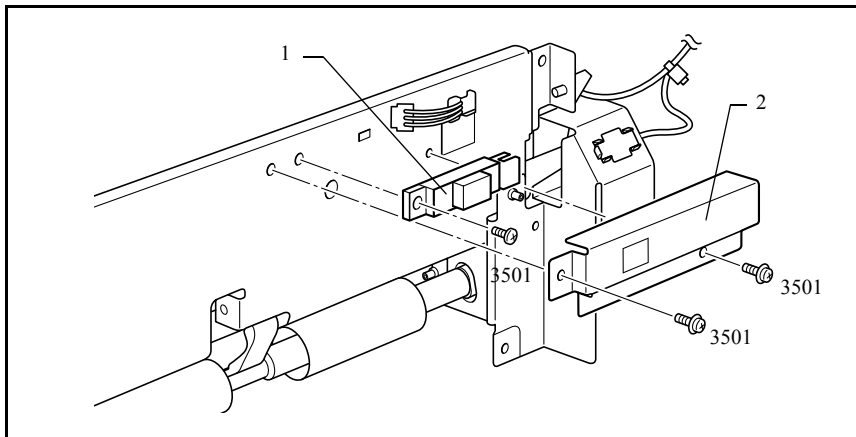

- 1 Paper empty sensor (PC2)
- 2 Sensor cover

Note

- When installing the sensor cover, be sure not to pinch the harness of the sensor.

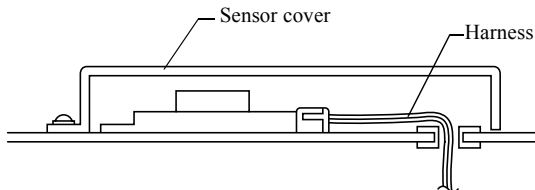

(5) Replacing the paper size detection switch (S1) and the paper near-empty sensor (PC3)

1. Remove the paper size detection assembly (1 screw and 2 connectors).
2. Remove the bracket (1 screw).
3. Remove the actuator.
4. Remove the paper size detection switch (S1).
5. Remove the paper near-empty sensor (PC3) (1 sensor stopper).

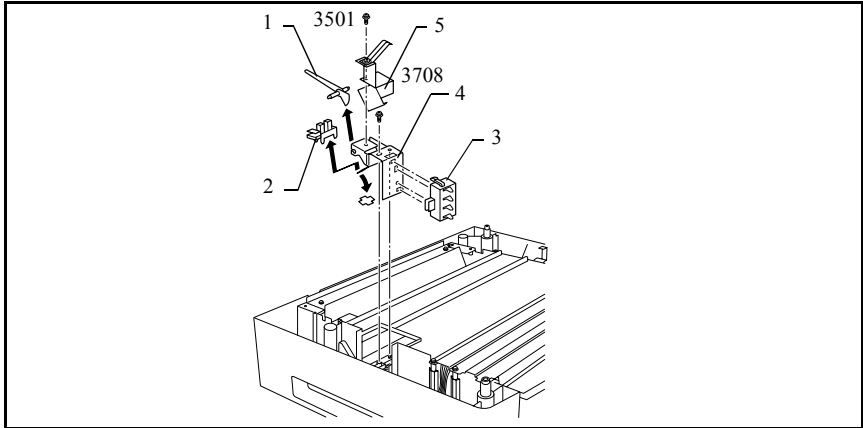

- 1 Actuator
- 2 Paper near-empty sensor (PC3)
- 3 Paper size detection switch (S1)
- 4 Paper size detection assembly
- 5 Bracket

Note

- When installing the actuator, make sure that it operates smoothly.
- When installing the paper near-empty sensor (PC3) and the paper size detection switch (S1), make sure that the tab of the detection switch extends from the top of the bracket.
- When installing a paper near-empty sensor (PC3), be sure to affix the sensor stopper.

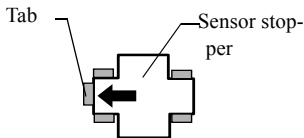

- When affixing the sensor stopper, be sure to position it as shown in the illustration. Make sure that the sensor stopper will not peel off or move out of place.

5-9. 4-bin mailbox disassembly procedures

(1) Replacing the lower transport sensor (PC9)

1. Remove the tray (4 screws).
2. Remove the tray cover.
3. Remove the sensor bracket (1 screw).
4. Remove the lower transport sensor (PC9).

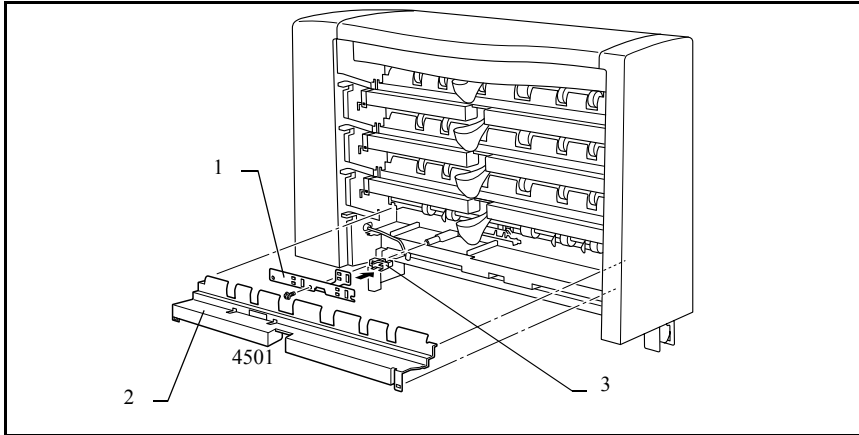

- 1 Sensor bracket
- 2 Tray cover
- 3 Lower transport sensor (PC9)

Note

- When installing the tray cover, make sure that the slot in the tray cover fits onto the cover-mounting tab.

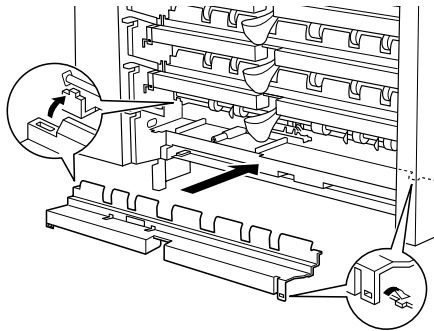

(2) Replacing the sensors of mailbins 1 and 3

Note

- The replacement procedure for the sensors of mailbins 1 and 3 is the same; only the part names differ.

1. Remove the tray (4 screws).
2. Remove the tray cover.
3. Remove the sensor bracket (1 screw).
4. Remove bin empty sensor 1 (PC1) [bin empty sensor 3 (PC3)] (1 screw).
5. Remove bin full sensor 1 (PC5) [bin full sensor 3 (PC7)].

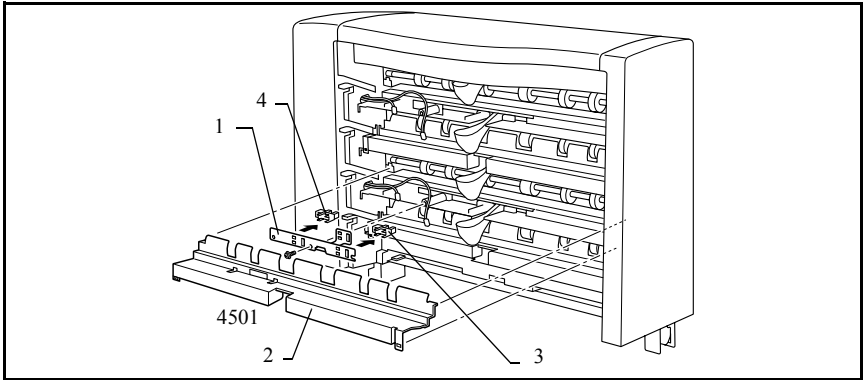

- 1 Sensor bracket
- 2 Tray cover
- 3 Bin full sensor 1 (PC5)/bin full sensor 3 (PC7)
- 4 Bin empty sensor 1 (PC1)/bin empty sensor 3 (PC3)

Note

- When installing the tray cover, make sure that the slot in the tray cover fits onto the cover-mounting tab.

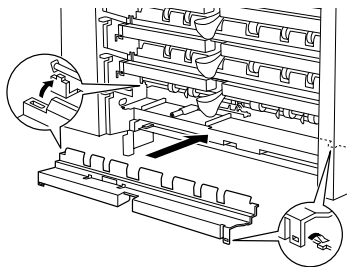

(3) Replacing the sensors of mailbin 2

1. Remove the tray (4 screws).
2. Remove the tray cover.
3. Remove the sensor bracket (1 screw).
4. Remove bin empty sensor 2 (PC2).
5. Remove bin full sensor 2 (PC6).
6. Remove the upper transport sensor (PC10).

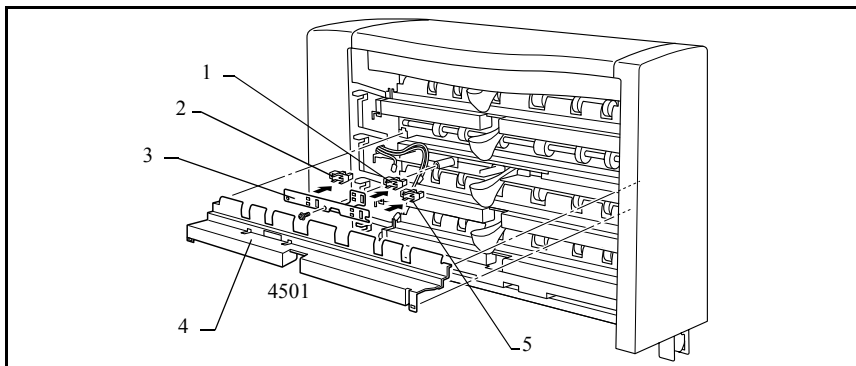

- 1 Upper transport sensor (PC10)
- 2 Bin empty sensor 2 (PC2)
- 3 Sensor bracket
- 4 Tray cover
- 5 Bin full sensor 2 (PC6)

Note

- When installing the tray cover, make sure that the slot in the tray cover fits onto the cover-mounting tab.

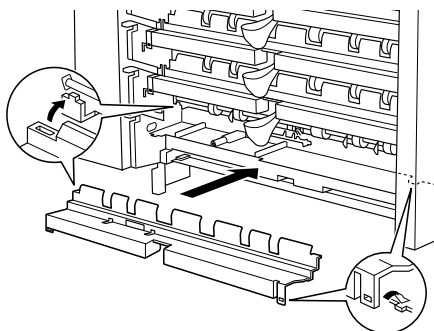

(4) Replacing the sensors of mailbin 4 and the cover sensor

1. Remove the tray (4 screws).
2. Remove the right cover (1 screw).
3. Remove the left cover (1 screw).

Note

- When removing the left and right covers, first remove the screw, and then pull the covers out and remove the tabs from the mailbin frame.
-

4. Remove the top cover.
5. Remove bin empty sensor 4 (PC4).
6. Remove bin full sensor 4 (PC8).
7. Remove the cover sensor (PC11).

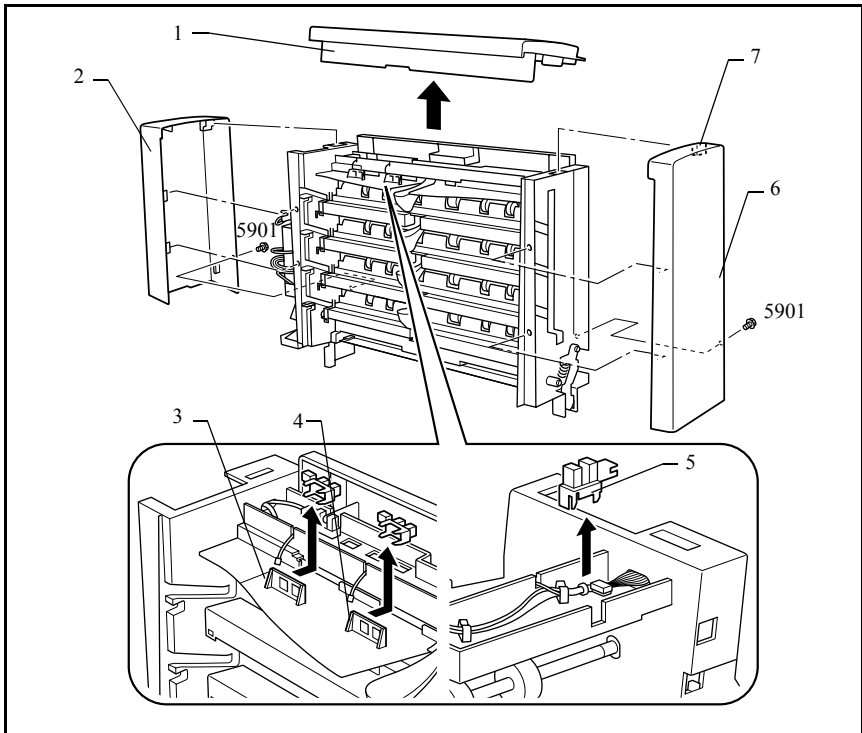

- 1 Top cover
- 2 Left cover
- 3 Bin empty sensor 4 (PC4)
- 4 Bin full sensor 4 (PC8)
- 5 Cover sensor (PC11)
- 6 Right cover
- 7 Tab

Note

- When installing the top cover, make sure that it is under the left and right covers.

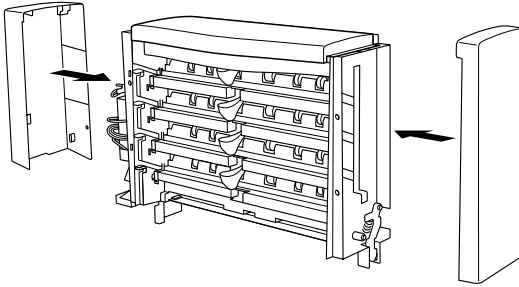

- When installing the left and right covers, make sure that the tabs on the covers fit into the slots in top the cover.
-

(5) Replacing the set sensor (PC12) and the control board (PWB-A)

1. Remove the set sensor cover.
2. Remove the docking lever assembly (2 screws and 2 connectors).
3. Remove the set sensor (PC12) (1 connector).

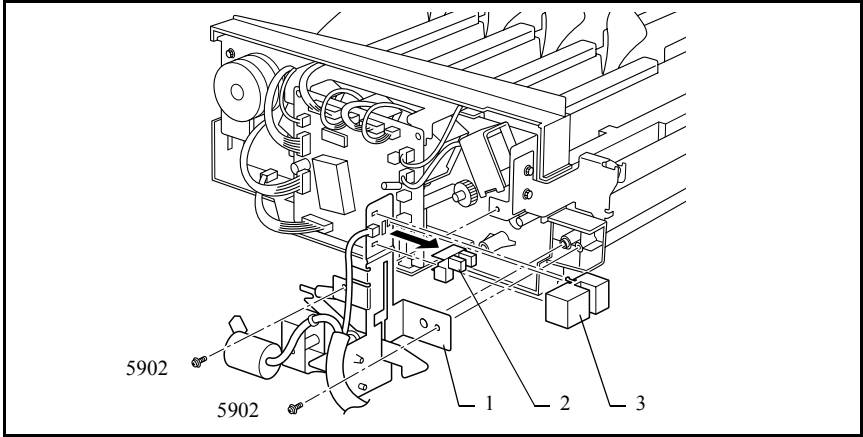

- 1 Docking lever assembly
- 2 Set sensor (PC12)
- 3 Set sensor cover

4. Remove the control board (PWB-A) (2 screws and 10 connectors).

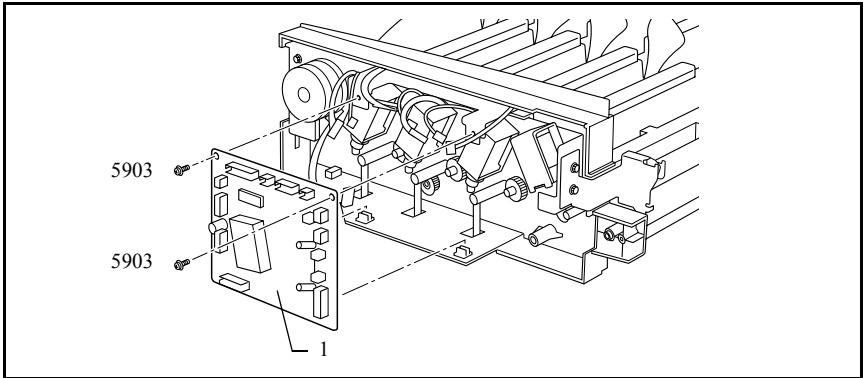

- 1 Control board (PWB-A)

(6) Replacing the transport motor (M1) and the solenoids

1. Remove the bracket for the motor and solenoids (4 screws, 1 drive belt, 4 torsion coil springs and 1 C-clip).
2. Remove the transport motor (M1) (2 screws).
3. Remove the entrance guide switching solenoid (SL1) (2 screws).
4. Remove the bin entrance switching solenoids (SL2 through SL4) (2 screws each).

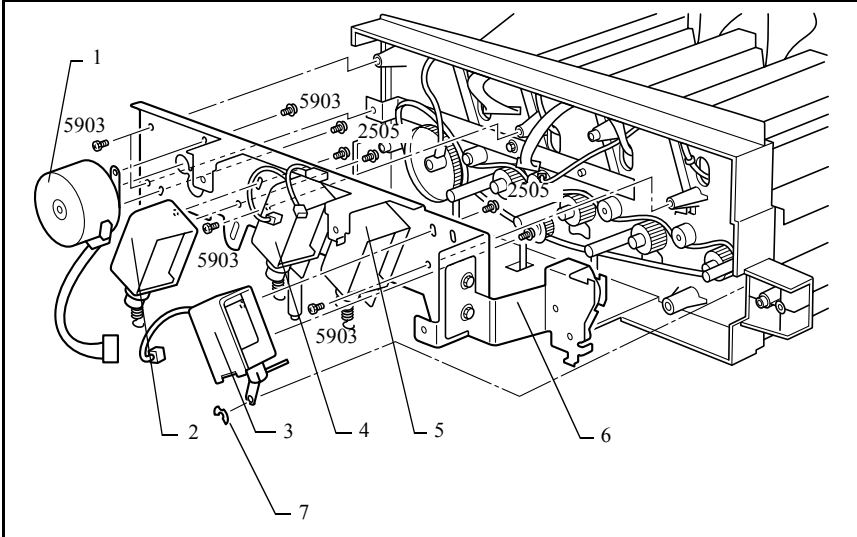

- 1 Transport motor (M1)
- 2 Bin entrance switching solenoid 3 (SL4)
- 3 Entrance guide switching solenoid (SL1)
- 4 Bin entrance switching solenoid 2 (SL3)
- 5 Bin entrance switching solenoid 1 (SL2)
- 6 Bracket for the motor and solenoids
- 7 C-clip (resin)

Note

- When installing the bracket for the motor and solenoids, perform the following gear adjustment.
- Assemble gears A, B and C as shown in the illustration, and then secure the shaft of gear A at the entrance guide switching solenoid (SL1) with the C-clip.

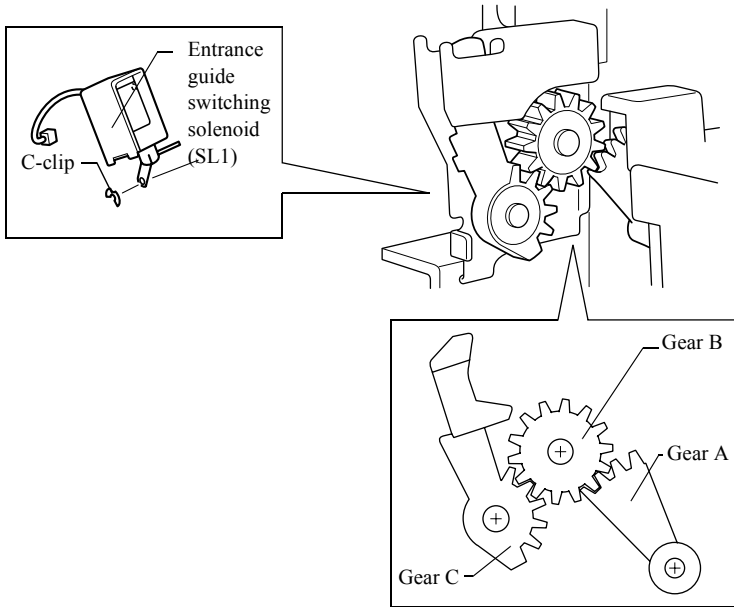

- Rotate gear C counterclockwise until it stops.

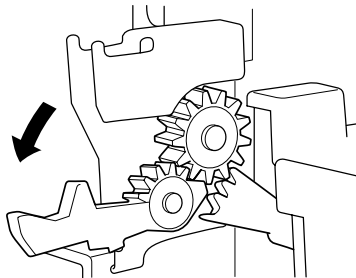

- Check the orientation of the bracket with gear C. (The angle of the section of gear C shown in the illustration with respect to the bracket should be adjusted to 90° to 94° .)

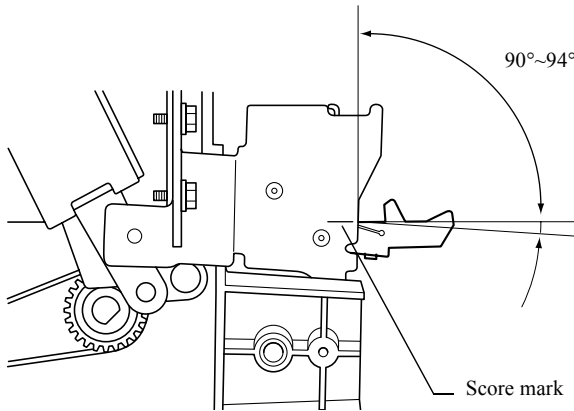

- If the angle of gear C is out of specification ($90^{\circ}\sim 94^{\circ}$), loosen the 2 gear bracket-securing screws, and then adjust the installation position of the gear bracket so that the angle of gear C is within specifications.

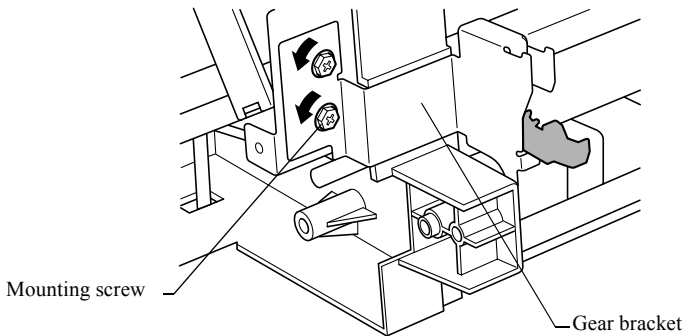

6. ADJUSTMENT

6-1. Adjustment of image registration

- After the Main Control Board (Controller board) is replaced, be sure to print of a sample image. If the starting position of the image (registration gap (d)=4mm) in the sub-scanning direction is not suitable, adjust the gap by following the procedure described below.
1. Remove the right cover, top front cover, front cover and rear cover (see "MAINTENANCE/DISASSEMBLY").
 2. Remove the shield cover so that VR of each Controller board can be adjusted.
 3. Use the core driver and turn the image-position-adjusting knob (VR1) to adjust the image position so that the image position (d) is 4 mm. Turn VR1 clockwise to make (d) larger or turn VR1 counterclockwise to make (d) smaller.

Print Image

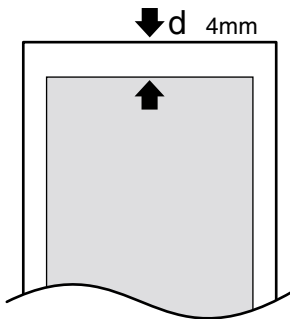

Main controlboard (PWB-A)

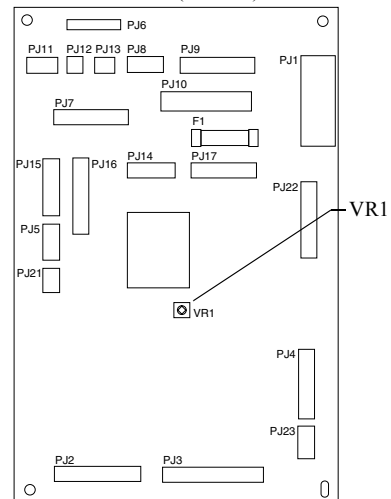

7. TROUBLESHOOTING

7-1. Paper misfeed detection

(1) Detecting paper remaining in the machine

According to the signal (H or L) from the following sensors, the printer determines whether or not paper remains in the machine.

1. Printer:
 - Paper sensor of the image transfer section (PC1)
 - Paper output sensor (PC3)
2. Second through fourth lower feeder units (optional)
 - Paper sensor (PC1)
3. Duplex unit (optional)
 - Duplex unit paper sensor (PC2)
4. 4-bin mailbox (optional)
 - Lower transport sensor (PC9)
 - Upper transport sensor (PC10)

(2) Detecting a paper misfeed while feeding

According to the timing rise or fall in the signal from the following sensors, the printer can detect a paper misfeed in the machine.

1. Printer:
 - Paper sensor of the image transfer section (PC1)
 - Paper output sensor (PC3)
2. Second through fourth lower feeder units (optional)
 - Paper sensor (PC1)
3. Duplex unit (optional)
 - Duplex unit paper sensor (PC2)
4. 4-bin mailbox (optional)
 - Lower transport sensor (PC9)
 - Upper transport sensor (PC10)

(3) Operation when a paper misfeed is detected

When a paper misfeed is detected, the following elements are stopped.

1. Printer:
 - Main motor (M1)
 - Imaging cartridge drive motor (M2)
2. Second through fourth media trays (optional)
 - Paper take-up clutch (CL1)
3. Duplex unit (optional)
 - Transport motor (M1)
 - Switchback motor (M2)
4. 4-bin mailbox (optional)
 - Transport motor (M1)

(4) Conditions under which a paper misfeed is detected

1. If the paper sensor of the image transfer section (PC1) does not detect the leading edge of the paper within a set length of time from the moment that paper feed-in from the multi-purpose paper tray or the first paper cassette begins (the paper take-up roller starts rotating).
2. If the paper sensor of the image transfer section (PC1) detects the leading edge of the paper earlier than the set length of time from the moment that paper feed-in from the multi-purpose paper tray or the first paper cassette begins (the paper take-up roller starts rotating).
3. If the paper output sensor (PC3) does not detect the leading edge of the paper within a set length of time after the paper sensor of the image transfer section (PC1) detects the leading edge of the paper.
4. If the trailing edge of the paper is not detected within a set length of time after the paper sensor of the image transfer section (PC1) detects the leading edge of the paper.
5. If the paper output sensor (PC3) does not detect the trailing edge of the paper within a set length of time after the paper sensor of the image transfer section (PC1) detects the trailing edge of the paper.
6. If the paper sensor (PC1) of the second through fourth paper cassette unit does not detect the leading edge of the paper within a set length of time from the moment that paper feed-in from the paper cassette begins (the paper take-up roller starts rotating).
7. If the paper sensor (PC1) of the lower feed unit, above the second through fourth paper cassette, that fed the paper does not detect the leading edge of the paper within a set length of time from the moment that the paper sensor (PC1) of the paper cassette feeding the paper detects the leading edge of the paper (For paper fed from the second paper cassette, this occurs if the paper sensor (PC1) of the image transfer section does not detect the leading edge of the paper.)

8. If the duplex unit paper sensor (PC2) does not detect the trailing edge of the paper within a set length of time from the moment that the paper output sensor (PC3) of the printer detects the trailing edge of the paper while feeding the paper the second time during double-sided printing.
9. If the lower transport sensor (PC9) of the 4-bin mailbox does not detect the leading edge of the paper within a set length of time from the moment that the paper output sensor (PC3) of the printer detects the leading edge of the paper during sorted printing.
10. If the lower transport sensor (PC9) of the 4-bin mailbox does not detect the leading edge of the paper within a set length of time from the moment that the paper output sensor (PC3) of the printer detects the trailing edge of the paper during sorted printing.
11. If the upper transport sensor (PC10) of the 4-bin mailbox does not detect the leading edge of the paper within a set length of time from the moment that the paper output sensor (PC3) of the printer detects the leading edge of the paper during sorted printing.
12. If the upper transport sensor (PC10) of the 4-bin mailbox does not detect the trailing edge of the paper within a set length of time from the moment that the paper output sensor (PC3) of the printer detects the trailing edge of the paper during sorted printing.

(5) Procedure for resetting after a paper misfeed is detected

To cancel a paper misfeed error, remove the misfed paper, and then open and close the top rear cover, the duplex unit cover or the 4-bin mailbox cover, or remove and insert the paper cassette. However, if a paper misfeed occurs where the paper remains in the machine, the reset procedure differs according to the location of the paper misfeed. Cancel the paper misfeed error depending on the following conditions.

1. For resetting by opening and closing the top rear cover
 - If the misfed paper was detected by the paper sensor (PC1) of the image transfer section or the paper output sensor (PC3) in the printer.
 - If the misfed paper was detected by the paper sensor (PC1) of the second through fourth lower feed unit.
2. For resetting by opening and closing the duplex unit cover
 - If the misfed paper was detected by the duplex unit paper sensor (PC2) of the duplex unit.
3. For resetting by opening and closing the 4-bin mailbox cover
 - If the misfed paper was detected by the lower transport sensor (PC9) or the upper transport sensor (PC10) of the 4-bin mailbox.
4. For resetting by closing and opening the multi-purpose paper tray
 - If the misfed paper was detected by the paper sensor (PC1) of the image transfer section in the printer.
 - If the misfed paper was detected by the paper sensor (PC1) of the second through fourth lower feed unit.
5. For resetting by removing and inserting the universal paper cassette
 - If the misfed paper was detected by the paper sensor (PC1) of the first through fourth lower feed unit.

7-2. Malfunction detection

When any of the following malfunctions are detected, all driving units are stopped, and the corresponding hardware error appears on the control panel.

(1) Laser malfunction - Service Call 10 H-Sync

1. If the -SOS signal is not detected within 200 ms after laser emission begins after the polygon motor (M5) is activated.

(2) Polygon motor malfunction - Service Call 0A Polygon Motor

1. If the -Polygon_M_Lock signal is not detected within 6 s after the polygon motor (M5) is activated.
2. If the -Polygon_M_Lock signal is not detected within 498 ms while the polygon motor (M5) is rotating.
3. If the -Polygon_M_Lock signal was detected for more than 4.998 s while the polygon motor (M5) is deactivated.

(3) Fusing malfunctions

Service Call 18 Fuser Warmup

1. A warm-up error is determined if the temperature detected by the thermistor does not reach 100 °C within 65 s from starting warm-up.
2. A warm-up error is determined if the temperature detected by the thermistor takes more than 30 s to reach 140 °C from 100 °C while warming up.
3. A warm-up error is determined if the temperature detected by the thermistor takes more than 20 s to reach 200 °C from 170 °C while warming up.
4. A warm-up error is determined if the temperature detected by the thermistor takes more than 22 s to reach 200 °C (or 190 °C if directly after turning on the printer) from 170 °C while warming up.

Service Call 19 Fuser Temp Low

5. A fusing high-temperature error is determined if the temperature detected by the thermistor falls to 130 °C and remains there for 100 ms during stand-by.
6. A fusing low-temperature error is determined if the temperature detected by the thermistor falls to 130 °C and remains there for 100 ms while printing.

Service Call 1A Fuser Overheat

7. A fusing high-temperature error is determined if the temperature detected by the thermistor rises to 230 °C and remains there for 102 ms during any of the modes.

(4) Power supply unit fan motor malfunction

Service Call 0C Power Supply

1. If the PSU_FAN_LOCK_PULSE signal is set to "H" for 1 s while the power supply unit fan motor (M4) is rotating.
2. If the PSU_FAN_LOCK_PULSE signal is set to "L" for 1 s while the power supply unit fan motor (M4) is stopped.

(5) Ozone fan motor malfunction

Service Call 0D Power Supply Fan 2

1. If the OZON_FAN_LOCK_PULSE signal is set to "H" for 1 s while the ozone fan motor (M6) is rotating.

(6) Fusing fan motor malfunction

Service Call 0B Internal Fan

1. If the FUSER_FAN_LOCK signal is set to "H" for 1 s while the fusing fan motor (M3) is rotating.
2. If the FUSER_FAN_LOCK signal is set to "L" for 1 s while the fusing fan motor (M3) is stopped.

(7) Image transfer voltage error

Service Call 0F High Voltage

1. If the image transfer voltage rises to 100 V (image transfer monitor voltage: T_MON) for 100 ms while the PC drum is stopped.

(8) Main motor malfunction

Service Call 08 Main Motor

1. If the lock signal "H" for the main motor is detected for 1 s after 1 s from activating the main motor (M1) (detected only while the main motor is activated).

(9) Imaging cartridge drive motor malfunction

Service Call 09 IC Motor

1. If the lock signal "H" for the imaging cartridge drive motor is detected for 1 s after 1 s from activating the imaging cartridge drive motor (M2) (detected only while the imaging cartridge drive motor is activated).

(10) 4-bin mailbox transmission error

Service Call 02 I/F Communication

1. If a transmission error signal (bus conflict loss or incorrect start condition) was detected during transmission with the 4-bin mailbox.

7-3. Troubleshooting for paper misfeeds

(1) Paper misfeed when the power switch is turned on

Check		Remedy
Is the paper in the machine?	→	<ul style="list-style-type: none"> Remove all paper remaining in the machine.
↓ No	Yes	
Are the actuators of the paper sensor (PC1) of the image transfer section, the paper output sensor (PC3) of the fusing section, the expansion paper cassette units, and the duplex unit paper sensor (PC2) operating correctly?	→	<ul style="list-style-type: none"> Re-install the actuator so that it operates correctly.
	↓ No	
	→	<ul style="list-style-type: none"> Replace the paper sensor of the image transfer section (PC1). Replace the paper output sensor of the fusing section (PC3). Replace the paper sensor of the paper cassette unit (PC1). Replace the main control board (PWB-A). Replace the control board of the duplex unit (PWB-A).
	↓ No	

(2) Paper misfeed between the paper feed-in section and the transport section

Check		Remedy
Are the take-up rollers at each paper inlet rotating?	→	<ul style="list-style-type: none"> Replace the paper take-up solenoid for the multi-purpose paper tray (SL1). Replace the paper take-up clutch for the first paper cassette (CL2). Replace the paper take-up clutch for the expansion paper cassette unit (CL1).
↓ Yes	No	
Is paper that conforms to the product specifications being used?	→	<ul style="list-style-type: none"> Instruct the user to use paper that conforms to the product specifications.
↓ Yes	No	
Is the paper curled, wavy or damp?	→	<ul style="list-style-type: none"> Change the paper and instruct the user on the correct method for storing paper.
↓ No	Yes	
Are the take-up rollers at each paper inlet deformed, scratched or dirty with paper dust?	→	<ul style="list-style-type: none"> Replace the paper take-up roller for the multi-purpose paper tray. Replace the paper take-up roller for the first paper cassette. Replace the paper take-up roller for the expansion paper cassette unit.
↓ No	Yes	
Is the actuator for the paper sensor of the image transfer section (PC1) operating correctly?	→	<ul style="list-style-type: none"> Re-install the actuator so that it operates correctly.
	↓ No	
	→	<ul style="list-style-type: none"> Replace the paper sensor of the image transfer section (PC1). Replace the main control board (PWB-A).
	↓ No	

(3) Paper misfeed between the transport section and the paper feed-out section

Check		Remedy
Is the image transfer roller deformed, scratched, or dirty with paper dust or toner? (Has it reached the end of its service life?)	→ Yes	• Replace the image transfer roller unit.
↓ No		
Are the heat roller or any other rollers in the fusing section deformed, scratched or dirty?	→ Yes	• Replace the fusing unit.
↓ No		
Is the paper output roller rotating?	→ No	• Replace the fusing unit.
↓ Yes		
Is the actuator for the paper-full detection sensor (PS3) operating correctly?	→ No	• Re-install the actuator so that it operates correctly.
↓ Yes		
Is the actuator for the paper output sensor (PC3) operating correctly?	→ No	• Re-install the actuator so that it operates correctly.
	→ Yes	• Replace the paper output sensor (PC3).
		• Replace the main control board (PWB-A).

(4) Paper jam display messages and associated sections

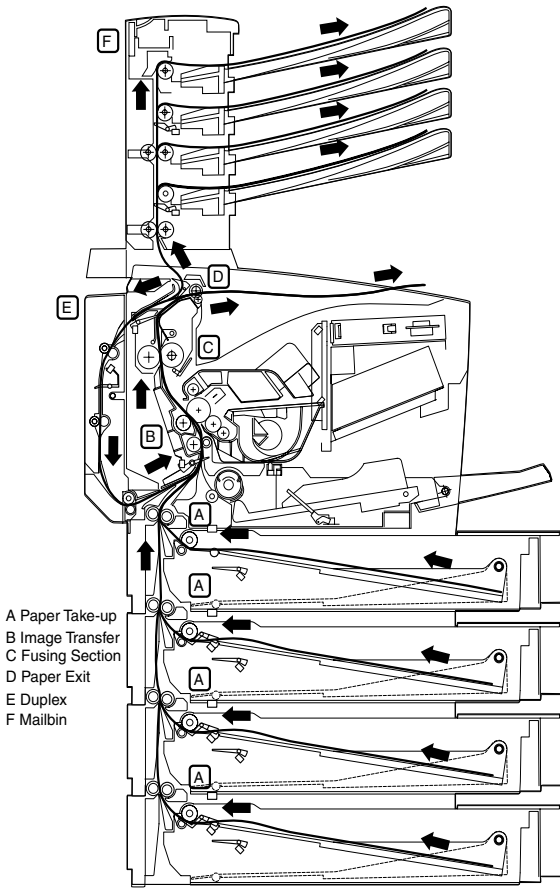

	Paper Jam Message	Location to be checked
1	Media Jam MPT	A
2	Media Jam Upper tray	A
3	Media Jam Optional 1 tray	A
4	Media Jam Optional 2 tray	A
5	Media Jam Optional 3 tray	A
6	Media Jam Transportr	A and B
7	Media Jam Drum	A and B
8	Media Jam Fuser	B, C and D
9	Media Jam Duplex	C, D and E
10	Media Jam Duplex Feeder	A, B and E
11	Media Jam Mail Bin	D and F

7-4. Troubleshooting for operation malfunctions

(1) Hardware errors

Check		Remedy
Did the error appear after warm-up was completed?	→	<ul style="list-style-type: none"> • Replace thermistor 1 (TH1) or the fusing unit. • Replace the main control board (PWB-A).
↓ No	Yes	
After turning on the printer, does the rotating of the polygon motor make noise while warming up?	→	<ul style="list-style-type: none"> • Replace the print head section. • Replace the main control board (PWB-A).
↓ Yes	No	
Is the fusing unit warm?	→	<ul style="list-style-type: none"> • Replace thermistor 1 (TH1). • Replace the fusing unit. • Replace the main control board (PWB-A).
↓ No	Yes	
Has interlock switch 2 (S3) been activated?	→	<ul style="list-style-type: none"> • Correctly install interlock switch 2 (S3).
↓ Yes	No	
Is there continuity between connectors CN2-1 and CN2-2 of the fusing unit?	→	<ul style="list-style-type: none"> • Replace the heater lamp (H1), the thermostat (TS1) or the thermal fuse (TF1). • Replace the fusing unit.
	No	
	→	<ul style="list-style-type: none"> • Replace interlock switch 2 (S3). • Replace the power supply board (PU1). • Replace the main control board (PWB-A).
	Yes	

(2) No power

Check		Remedy
Has the power switch (S1) been turned on?	→	<ul style="list-style-type: none"> • Turn on the power switch (S1).
↓ Yes	No	
Is the power cord correctly connected to the printer?	→	<ul style="list-style-type: none"> • Turn off the power switch (S1), and then correctly connect the power cord.
↓ Yes	No	
Is the power cord plugged into an electrical outlet?	→	<ul style="list-style-type: none"> • Turn off the power switch (S1), and then correctly plug the power cord into the outlet.
↓ Yes	No	
Has interlock switch 1 (S2) been activated?	→	<ul style="list-style-type: none"> • Correctly install interlock switch 1 (S2).
↓ Yes	No	
Is there continuity in the fuses (F1 and F2) of the power supply board (PWB-E)?	→	<ul style="list-style-type: none"> • Replace the fuses (F1 and F2).
↓ Yes	No	
Is there continuity in the fuse (F1) of the main control board (PWB-A)?	→	<ul style="list-style-type: none"> • Replace the fuse (F1).
	No	
	→	<ul style="list-style-type: none"> • Replace the power supply board (PU1). • Replace the main control board (PWB-A).
	Yes	

7-5. Image quality troubleshooting

When an image problem occurs, exchange the Imaging Cartridge a new one and determine whether the cause of the problem is due to the cartridge or something else in the printer. If the problem still occurs, please use the following chart to help determine the defective unit

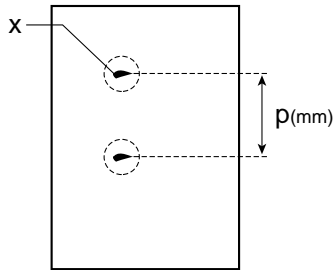

Pitch	Possible defective part	Unit to be replaced
41.1 mm	Developing roller	Imaging cartridge
94.2 mm	PC Drum	
50.6 mm	Image transfer roller	Image transfer roller unit
93.3 mm	Heat roller	Fusing unit
87.9 mm	Compression roller	

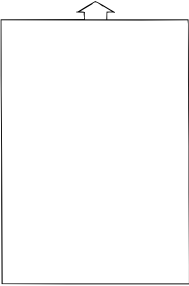
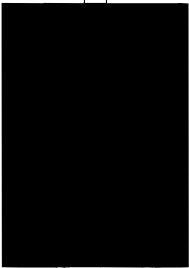
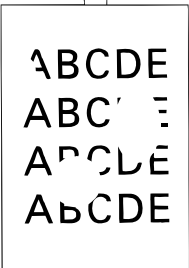
Symptom	Cause	Remedy
Blank print  0951o220	No imaging cartridge installed	<ul style="list-style-type: none"> • Install the imaging cartridge.
	No toner in imaging cartridge	<ul style="list-style-type: none"> • Replace the imaging cartridge.
	Defective PC drum (end of service life)	<ul style="list-style-type: none"> • Replace the imaging cartridge.
	Improper laser exposure	<ul style="list-style-type: none"> • Replace the print head unit.
		<ul style="list-style-type: none"> • Replace the print head section. • Replace the main control board (PWB-A).
Poor development	<ul style="list-style-type: none"> • Replace the imaging cartridge. 	
Black print  0951o213	Improper laser exposure	<ul style="list-style-type: none"> • Replace the print head unit. • Replace the print head section. • Replace the main control board (PWB-A).
	Improper charging	<ul style="list-style-type: none"> • Replace the high voltage unit (HV1). • Replace the main control board (PWB-A).
White spots  0951o211	Damp paper	<ul style="list-style-type: none"> • Replace the paper.
	Poor image transfer	<ul style="list-style-type: none"> • Replace the image transfer roller unit. • Replace the high voltage unit (HV1). • Replace the main control board (PWB-A).

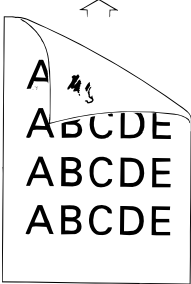
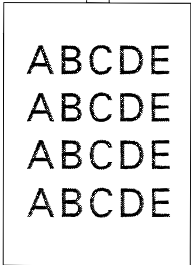
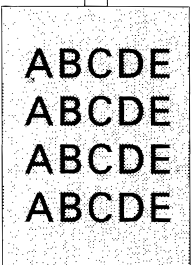
Symptom	Cause	Remedy
Toner smudges on backside of paper 	Dirty heat roller	<ul style="list-style-type: none"> • Replace the heat roller. • Replace the fusing unit.
	Dirty image transfer roller	<ul style="list-style-type: none"> • Replace the image transfer roller unit.
	Dirty paper transport path	<ul style="list-style-type: none"> • Clean the paper path within the printer.
Low image density 	No toner in imaging cartridge	<ul style="list-style-type: none"> • Replace the imaging cartridge.
	Defective PC drum (end of service life)	
	Poor developing bias	<ul style="list-style-type: none"> • Replace the high voltage unit (HV1). • Replace the main control board (PWB-A).
	Poor image transfer	
	Incorrect temperature detection	<ul style="list-style-type: none"> • Replace thermistor 2 (TH2).
Incorrect humidity detection	<ul style="list-style-type: none"> • Replace humidity sensor (HS1). 	
Foggy background 	Poor developing bias	<ul style="list-style-type: none"> • Replace the high voltage unit (HV1). • Replace the main control board (PWB-A).
	Improper charging	
	Incorrect temperature detection	<ul style="list-style-type: none"> • Replace thermistor 2 (TH2).
	Incorrect humidity detection	<ul style="list-style-type: none"> • Replace humidity sensor (HS1).
	Defective PC drum (end of service life)	<ul style="list-style-type: none"> • Replace the imaging cartridge.

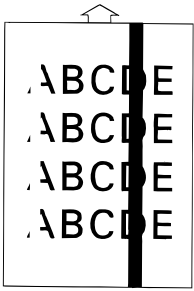
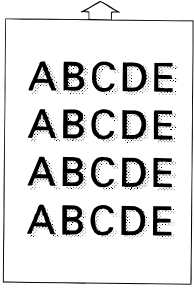
Symptom	Cause	Remedy
<p data-bbox="124 140 344 164">White/Black lines and bands</p> 	<p data-bbox="367 140 516 164">Scratched PC drum</p> <p data-bbox="367 172 524 196">Defective print head</p>	<ul data-bbox="669 140 924 220" style="list-style-type: none"> • Replace the imaging cartridge. • Replace the print head unit. • Replace the print head section.
<p data-bbox="124 507 225 531">Offset image</p> 	<p data-bbox="367 507 538 531">Defective fusing roller</p>	<ul data-bbox="669 507 879 555" style="list-style-type: none"> • Replace the fusing roller. • Replace the fusing unit.

INDEX

A

- Acoustic noise 21
- Adjustment of image registration 155

B

- Biasing 65
- Bin empty sensors (PC1~PC4) 84
- Bin entrance switch solenoid (SL2 through SL4) 83
- Bin full sensors (PC5~PC8) 84
- Bin-switching 83
- Black print 168
- Blank print 168

C

- Cautions 4
 - Dis/Reassembly 9
 - Handling of PWBs 9
 - Imaging Cartridge 10
 - Laser Beam 5
 - Service Jobs 4
 - Working Environment 4
- Charging 65
- Cleaning schedule 87
- Cleaning the PC drum 68
- Compression roller 69
- Corona 65

D

- Development 67
- Disassembly procedures
 - Duplex unit 139
- Dimensions 21
- Disassembly procedure chart 89
- Disassembly procedures
 - Lower feed unit 141
 - Mailbox 146
 - Printer 89
- Drive components 47
- Drive mechanism, mailbox 81
- Drive system 27
- Drive-switching mechanism 76
- Drum charging 65
- Duplex section 78
 - Double-sided printing mechanism 80
 - Single-sided printing mechanism 79
- Duplex unit disassembly procedures 139
 - Control board (PWB-A) 139
 - Duplex cover switch (PC1) 139
 - Switchback motor (M2) 139
 - Transport motor (M1) 139
- Duplex unit paper sensor (PC2) 80

Duplex unit specifications 23

Dimensions 23

Media sizes 23

Media types 23

Weight 23

E

Electrical components functions 34

Electrical components layout 30

4-bin mailbox 33

Duplex unit 32

Lower feed unit 32

Printer 30

Entrance guide switching solenoid (SL1) 82

Error Codes

Service Call 02 I/F Communication 162

Service Call 08 Main Motor 162

Service Call 09 IC Motor 162

Service Call 0B Internal Fan 162

Service Call 0C Power Supply 161

Service Call 0D Power Supply Fan 2 161

Service Call 0F High Voltage 162

Service Call 18 Fuser Warmup 161

Service Call 19 Fuser Temp Low 161

Service Call 1A Fuser Overheat 161

Exhaust filter 90, 96

Exit section 74

Exposure 66

Exposure method 19

F

Fan_lock_pulse signal 161

Fed paper detection 84

Foggy background 169

Full mailbin detection 84

FUSER_FAN_LOCK signal 162

Fusing 69

Fusing temperature control circuit 70

Hardware protection 73

Heater lamp control 70

Overheat protection 73

Software protection 73

Temperature control mode during stand-by 71

Temperature control modes during printing 72

Fusing fan motor malfunction 162

Fusing malfunctions 161

G

Grid voltage 65

H

Handling of PWBs 9

Handling of the Imaging Cartridge 10

Hardware errors 166

Heat roller 69
Heater lamp 69
Heater lamp control 70
High-temperature error 161
HV1 (high voltage unit) 39

I

Image quality troubleshooting 167

- Black print 168
- Blank print 168
- Foggy background 169
- Low image density 169
- Offset image 170
- Toner smudges on backside of paper 169
- White spots 168
- White/Black lines and bands 170

Image registration 155
Image transfer 68
Image transfer voltage error 162
Imaging cartridge 61

- Toner empty detection 63

Imaging cartridge drive motor malfunction 162
Imaging cartridge life 21
Installation 15

- Environment 15
- Space requirements 17
- Usage environment 16

J

Jams 163

L

Laser exposure 66
Laser malfunction 161
Latent electrostatic image 67
Low image density 169
Lower feed unit

- Paper feed retry control 56

Lower feed unit disassembly procedures 141

- Control board (PWB-A) 141
- Paper empty sensor (PC2) 144
- Paper near-empty sensor (PC3) 145
- Paper sensor (PC1) 143
- Paper size detection switch (S1) 145
- Paper take-up clutch (CL1) 142

Lower feed unit specifications 22

- Dimensions 22
- Media sizes 22
- Paper cassette capacity 22
- Weight 22

Lower transport sensor (PC9) 81
Low-temperature error 161

M

- Mailbox 81
 - Bin-switching mechanism 83
 - Drive mechanism 81
 - Fed paper detection mechanism 84
 - Full mailbin detection mechanism 84
 - Paper-switching mechanism 82
- Mailbox disassembly procedures 146
 - Control board (PWB-A) 151
 - Cover sensor 149
 - Lower transport sensor (PC9) 146
 - Sensors of mailbin 2 148
 - Sensors of mailbin 4 149
 - Sensors of mailbins 1 and 3 147
 - Set sensor (PC12) 151
 - Solenoids 152
 - Transport motor (M1) 152
- Mailbox specifications 23
 - Capacity 23
 - Dimensions 23
 - Weight 23
- Mailbox transmission error 162
- Main motor malfunction 162
- Maintenance schedule 87
- Maintenance/Disassembly 85
 - Cleaning schedule 87
 - List of screws used 88
 - Maintenance schedule 87
 - Precautions 85
 - Printer disassembly procedures 89
 - Required service tools 87
- Malfunction detection
 - 4-bin mailbox transmission error 162
 - Fusing fan motor malfunction 162
 - Fusing malfunctions 161
 - Image transfer voltage error 162
 - Imaging cartridge drive motor malfunction 162
 - Laser malfunction 161
 - Main motor malfunction 162
 - Ozone fan motor malfunction 161
 - Polygon motor malfunction 161
 - Power supply unit fan motor malfunction 161
- Media sizes 19
- Media types 19
- Multipurpose paper tray
 - Paper empty detection mechanism 53
 - Paper feed retry control 52
 - Paper near-empty detection mechanism 54
 - Paper take-up mechanisms & process 50

N

Needle electrode 65

No power 166

O

Offset image 170

Operation malfunctions

 Hardware errors 166

 No power 166

Overheat error 161

Overheat hardware protection 73

Overheat protection 73

Overheat software protection 73

Overview of the drive system 27

OZON_FAN_LOCK_PULSE signal 161

Ozone fan motor malfunction 161

P

Paper capacity 20

Paper empty detection 57

Paper empty sensor (PC2) 58

Paper empty sensor (PC6) 57

Paper exit section 74

 Drive-switching mechanism 76

 Paper-full detection mechanism 75

 Paper-output-switching 77

Paper feed retry control 56

Paper jam display messages 165

Paper misfeed detection

 Conditions 158

 Operation 158

 Paper misfeed while feeding 157

 Paper remaining in the machine 157

 Procedure for resetting 160

Paper misfeeds

 Between the paper feed-in section and the transport section 163

 Between the transport section and the paper feed-out section 164

 When the power switch is turned on 163

Paper near-empty detection 59

Paper near-empty sensor (PC3) 59

Paper near-empty sensor (PC5) 54

Paper near-empty sensor (PC7) 59

Paper output sensor (PC3) 79

Paper path 47

Paper size detection 60

Paper size detection switch (S4) 60

Paper take-up mechanism 55

Paper take-up motor (M1) 142

Paper take-up roller drive gear 50

Paper take-up section 50

Paper take-up solenoid (SL1) 50

Paper-full detection mechanism 75

- Paper-full detection sensor (PS3) 75
- Paper-output-switching mechanism 77
- Paper-switching mechanism 82
- PC Drum 20
- Polygon motor malfunction 161
- Polygon_M_Lock signal 161
- Power supply unit fan motor malfunction 161
- Print mechanism, duplexer 80
- Print resolution 19
- Printer disassembly procedures
 - Control panel 120
 - Fusing fan motor (M3) 136
 - Heat roller 107
 - Heater (H1) 107
 - High voltage unit (HV1) 130
 - Humidity sensor (HS1) 122
 - Image transfer roller unit 116
 - Imaging cartridge drive motor (M2) 133
 - Imaging-cartridge detection board (PWB-D) 117
 - Interlock switch 1 (S2) 124
 - Interlock switch 2 (S3) 132
 - Main control board (PWB-A) 125
 - Main motor (M1) 133
 - Outer covers 118
 - Ozone fan motor (M6) 128
 - Paper empty sensor (PC4) MPT 99
 - Paper empty sensor (PC6) first cassette 134
 - Paper empty sensor (PC6) for the first paper cassette 102
 - Paper near-empty sensor (PC5) MPT 99
 - Paper output sensor (PC3) of the fusing section 115
 - Paper sensor (PC1) 137
 - Paper size detection switch (S4) first cassette 134
 - Paper take-up clutch (CL2) first cassette 134
 - Paper take-up rollers cassette 103
 - Paper take-up solenoid (SL1) MPT 101
 - Paper-separating roller cassette 103
 - Power supply board (PU1) 129
 - Power supply unit fan motor 123
 - Power switch (S1) 131
 - Pre-disassembly preparation 1 90
 - Pre-disassembly preparation 2 91
 - Pre-disassembly preparation 3 92
 - Pre-disassembly preparation 4 93
 - Pre-disassembly preparation 5 94
 - Print head unit 127
 - Replacing the exhaust filter 96
 - Replacing the paper take-up roller of the MPT 97
 - Shield 121
 - Thermal fuse (TF1) 107
 - Thermistor 1 (TH1) 107
 - Thermistor 2 (TH2) 122

Thermostat (TS1) 107
Toner empty detection board (PWB-G) 98
Transport roller clutch (CL1) 137
Printer timing 45
PSU_FAN_LOCK_PULSE signal 161
PU1 (power supply board) 38
PWB-A (control board of the 4-bin mailbox) 42
PWB-A (control board of the lower feed unit) 41
PWB-A (DUP) (control board of the duplex unit) 41
PWB-A (main control board) 37
PWB-D 38
PWB-G (toner-empty detection board) 40
PWB-H (paper full detection board) 40
PWB-O (control panel board) 40

R

Registration adjustment 155
Roller diameters chart 167

S

Safety information 11
 Internal Laser Radiation 11
 Laser 11
Safety Precautions 1
 Graphic symbols 1
Scheduled cleaning 87
Scheduled maintenance 87
Screws 88
Service Call 02 I/F Communication 162
Service Call 08 Main Motor 162
Service Call 09 IC Motor 162
Service Call 0B Internal Fan 162
Service Call 0C Power Supply 161
Service Call 0D Power Supply Fan 2 161
Service Call 0F High Voltage 162
Service Call 18 Fuser Warmup 161
Service Call 19 Fuser Temp Low 161
Service Call 1A Fuser Overheat 161
Service tools 87
Sorter 81
SOS signal 161
Specifications 19
 Printer 19
Stand-by temperature control 71
Static discharge 68
Switchback motor (M2) 76, 78

T

Temperature control circuit 70
Temperature control modes 72
Thermistor 1 (TH1) 70
Timing chart 45
Toner cartridge components 61



- Toner cartridge operation 67
- Toner empty detection 63
- Toner empty detection board (PWB-G) 63
- Toner empty status 64
- Toner smudges 169
- Tools 87
- Transfer 68
- Troubleshooting 157
 - Image quality 167
 - Malfunction detection 161
 - Operation malfunctions 166
 - Paper misfeed detection 157
 - Paper misfeeds 163

U

- Universal paper cassette
 - Paper empty detection mechanism 57, 58
 - Paper feed retry control 55
 - Paper near-empty detection mechanism 59
 - Paper size detection mechanism 60
 - Paper take-up mechanism 55
- Upper transport sensor (PC10) 81

V

- Video interface 43

W

- Warm-up error 161
- Warm-up time 20
- Warnings 1
 - Grounded connection 2
 - High-temperature 2
 - High-voltage parts 2
 - Power cord 1
- Waste toner storage 61
- Weight 21
- White spots 168
- White/Black lines and bands 170

#PagePro 9100 PARTS LIST

PREFACE

1. The part numbers listed in this Parts List are those which were assigned to the parts making up the machine at the time machine was originally introduced onto the market.
2. Parts whose INDEX numbers are shown white against a black background in the illustration are those to be used in only certain market areas. These part numbers are given in the lower half part of the list section. Check the SFIX No. listed in SFIX CHART to find which part number is applicable to your own area.
3. Parts whose INDEX numbers are shown black against a white background in the illustration are those to be used in all market areas. These parts are listed on the upper half part of the list section.
4. If "NS" follows a part number given in the list section, it indicates that we do not keep a stock of the part. The part is not required for ordinary service jobs, either.
5. If "RP" is shown in the REC column of the list section, it indicates that the part is functionally important.
6. In the exploded views in this Parts List the parts (Screws & Washes, etc...) which are indicated with a "four-digit" numbers are listed in numerical order in the section "SCREWS AND WASHERS". Please check these "four-digit" numbers with the part numbers ("ten-digit" numbers) which should be used for ordering the part.
7. **All part numbers listed in this Parts List consist of ten digits. However, you must add the special MINOLTA-QMS "831" prefix to the beginning of the part number when ordering a part. The price of parts can be obtained by referring to the "Parts Price List" which is separately issued.**
8. All information contained in this Parts List is subject to change.

SFIX CHART

SFIX No.	COUNTRY	VOLTAGE	FREQUENCY (Hz)	PAPER SIZE	SFIX No.	COUNTRY	VOLTAGE	FREQUENCY (Hz)	PAPER SIZE
002	JAPAN	100V	50/60	METRIC	302	USA/CANADA	120V	60	INCH
202	EUROPE	220-240V	50	METRIC					

CONTENTS

1.	HOUSING	176
2.	FRAME (A)	178
3.	FRAME (B)	180
4.	FRAME (C)	182
5.	FUSING SECTION (A)	184
6.	FUSING SECTION (B)	186
7.	PAPER TRANSPORT SECTION	188
8.	DRIVE SECTION	190
9.	MULTIPLE PURPOSE TRAY	192
10.	UNIVERSAL CASSETTE	194
11.	DUPLEX UNIT (OPTION)	Duplex 196
12.	UNIVERSAL CASSETTE (A) (OPTION)	Lower Feeder Unit 198
13.	UNIVERSAL CASSETTE (B) (OPTION)	Lower Feeder Unit 200
14.	UNIVERSAL CASSETTE (C) (OPTION)	Lower Feeder Unit 202
15.	HOUSING (OPTION)	4-Bin Mailbox 204
16.	PAPER EXIT SECTION (OPTION)	4-Bin Mailbox 206
17.	ELECTRICAL COMPONENTS (OPTION)	4-Bin Mailbox 208
18.	SCREWS AND WASHERS	210
19.	NUMERICAL INDEX	211

January 2002

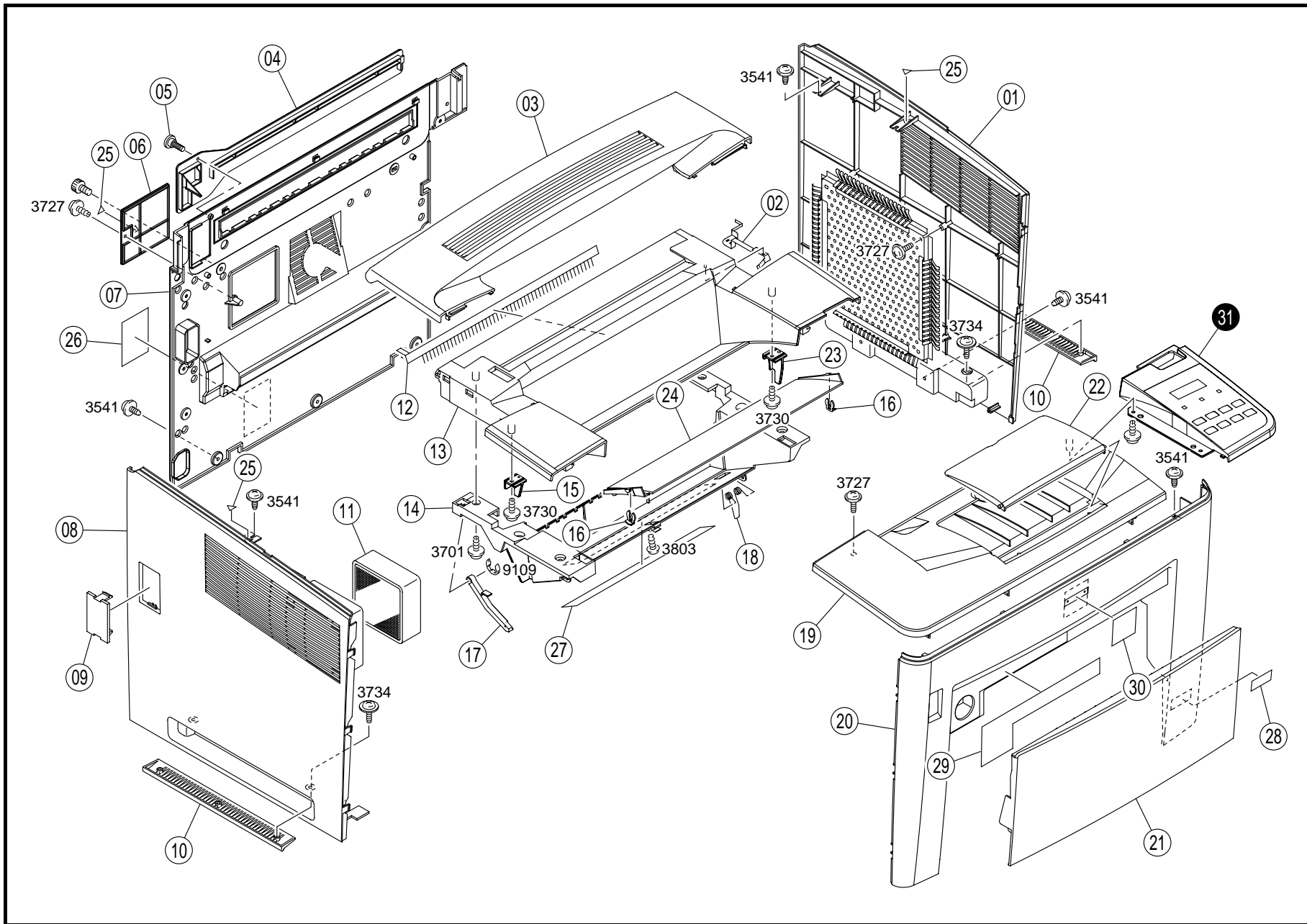

INDEX	PART NO.	PART NAME	REC	QTY	INDEX	PART NO.	PART NAME	REC	QTY
01	4128-1003-03	COVER		1	19	4128-1002-01	COVER		1
02	4128-5814-01	EARTH GROUND		1	20	4128-1005-01	FRONT COVER		1
03	4128-1019-01	COVER		1	21	4128-1006-01	TRAY		1
04	4128-1010-01	COVER		1	22	4128-1012-01	TRAY		1
05	4128-1221-01	SHOULDER SCREW		1	23	4128-1014-02	LEVER		1
06	4128-1026-01	COVER		1	24	4128-1007-01	TRAY		1
07	4128-1008-02	REAR COVER		1	25	0951-7105-03	LABEL		3
08	4128-1004-01	COVER		1	26	4004-7402-01	LABEL		1
09	4128-1020-02	COVER		1	27	4128-7325-01	LABEL		1
10	4128-1225-01	HANDLE		2	28	4128-7326-01	LABEL		1
11	4011-2032-01	FILTER	RP	1	29	4128-7320-01	LABEL		1
12	4128-5823-01	NEUTRALIZING BRUSH		1	30	4120-7362-01	LABEL		1
13	4128-1031-03	COVER		1					
14	4128-1039-02	TRAY		1					
15	4128-1015-01	LEVER		1					
16	4128-1227-01	RING		2					
17	4128-1013-04	LEVER		1					
18	4128-1230-01	TORSION SPRING		1					
INDEX	PART NO.	PART NAME	REC	QTY	SFIX				
31	4128-0108-05	PWB ASSY O-PANEL (PWB-O)	RP	1	202, 302				
31	4128-0110-03	PWB ASSY O-PANEL (PWB-O)	RP	1	002				

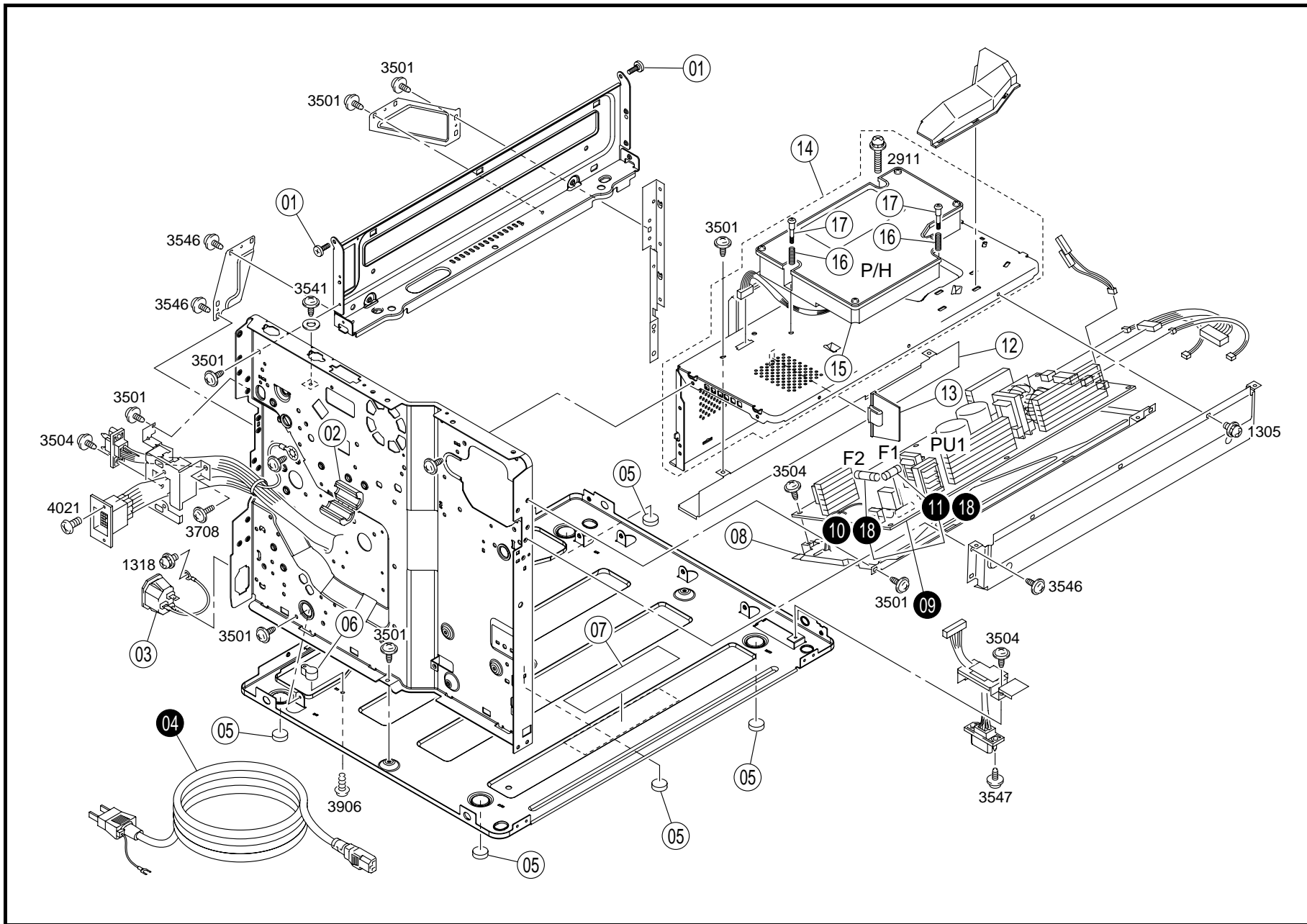

INDEX	PART NO.	PART NAME	REC	QTY	INDEX	PART NO.	PART NAME	REC	QTY
01	4128-1222-01	SHOULDER SCREW		2					
02	9326-1910-21	FERRITE CORE		1					
03	4128-6807-01	WIRE HARNESS ASSY		1					
05	4128-2019-01	RUBBER FOOT		5					
06	4128-2032-01	GUIDE		1					
07	4128-7312-01	LABEL		1					
08	4128-2211-02	BRACKET		1					
12	4128-2212-01	SHIELD		1					
13	4128-2031-01	REGULATING PLATE		1					
14	4128-0532-02	PRINT HEAD UNIT	(P/H) RP	1					
15	4128-0551-01	PRINT HEAD UNIT		1					
16	4128-1978-01	PRESSURE SPRING		2					
17	4128-1979-01	SHOULDER SCREW		2					
INDEX	PART NO.	PART NAME	REC	QTY	SFIX				
04	9381-4100-11	POWER CORD		1	002				
04	9381-4910-71	POWER CORD		1	202				
04	9381-4911-01	POWER CORD		1	302				
09	4128-6201-14	POWER SUPPLY	POWER (PU1) RP	1	002, 302				
09	4128-6202-14	POWER SUPPLY	POWER (PU1) RP	1	202				
10	9346-3720-51	FUSE 15A	(F2) RP	1	002, 302				
11	9346-3810-61	FUSE 10A	(F1) RP	1	002, 302				
18	1138-7811-01	FUSE 5A	(F1.2) RP	2	202				

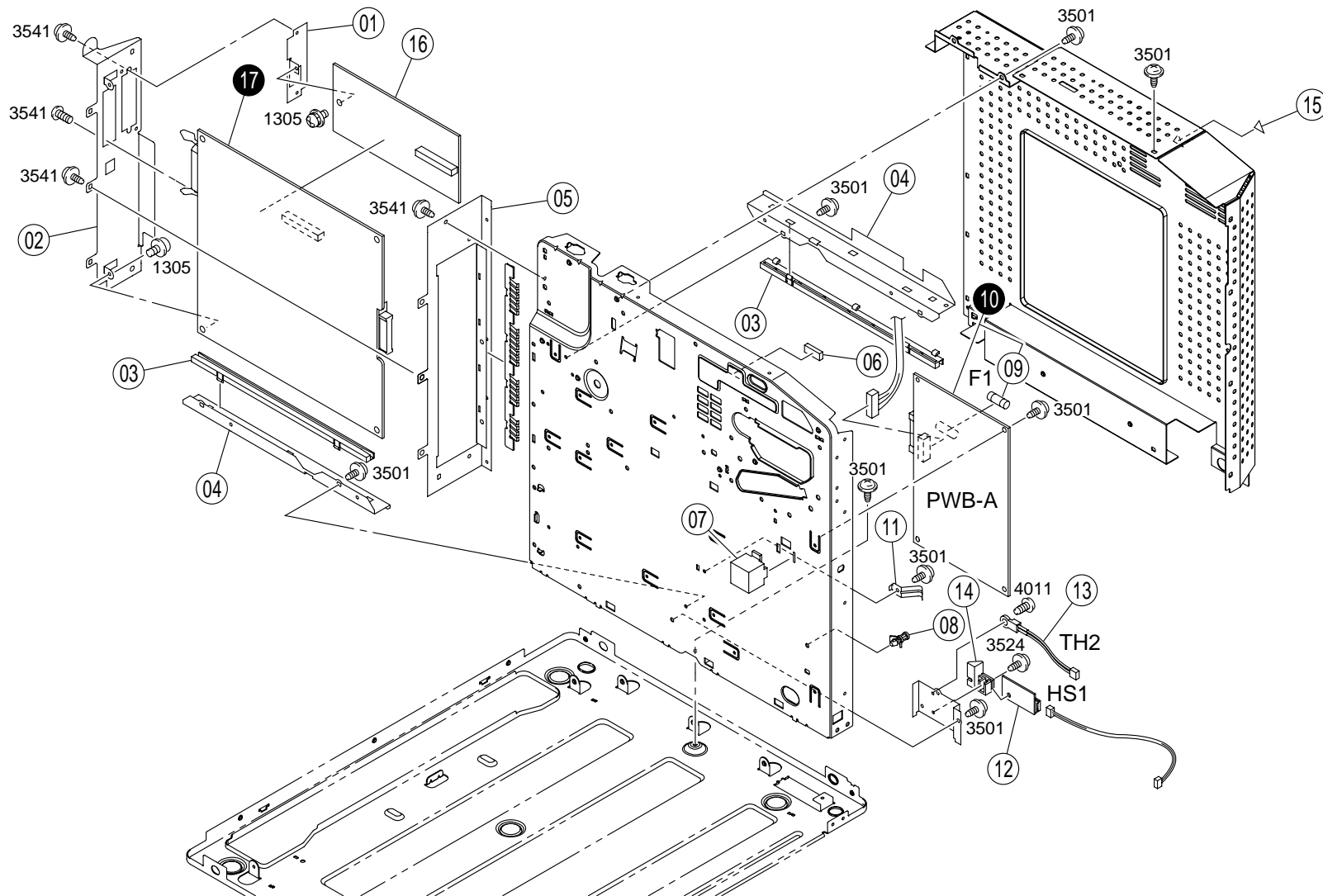

INDEX	PART NO.	PART NAME	REC	QTY	INDEX	PART NO.	PART NAME	REC	QTY
01	4128-2272-01	BRACKET		1					
02	4128-2270-01	BRACKET		1					
03	4128-2263-01	RAIL		2					
04	4128-2264-02	BRACKET		2					
05	4128-2262-02	BRACKET		1					
06	4128-2043-01	SEAL		1					
07	4128-3051-01	STOPPER		1					
08	9384-1900-55	PWB SUPPORT 9.53H		1					
09	9346-3000-11	FUSE (F1)	RP	1					
11	4128-2269-01	EARTH GROUND		1					
12	9372-5910-11	HUMIDITY CONVERSION EL. HUMIDITY (HS1)		1					
13	9372-2710-21	THERMISTOR THERMISTOR (TH2)	RP	1					
14	4120-3255-02	HOLDER		1					
15	0951-7105-03	LABEL		1					
16	4128-6055-01	PWB ASSY	RP	1					
INDEX	PART NO.	PART NAME	REC	QTY	SFIX				
10	4128-0109-02	PWB ASSY MAIN (PWB-A)	RP	1	002, 302				
10	4128-0112-01	PWB ASSY MAIN (PWB-A)	RP	1	202				
17	4128-6054-02	PWB ASSY	RP	1	202, 302				
17	4128-6056-02	PWB ASSY	RP	1	002				

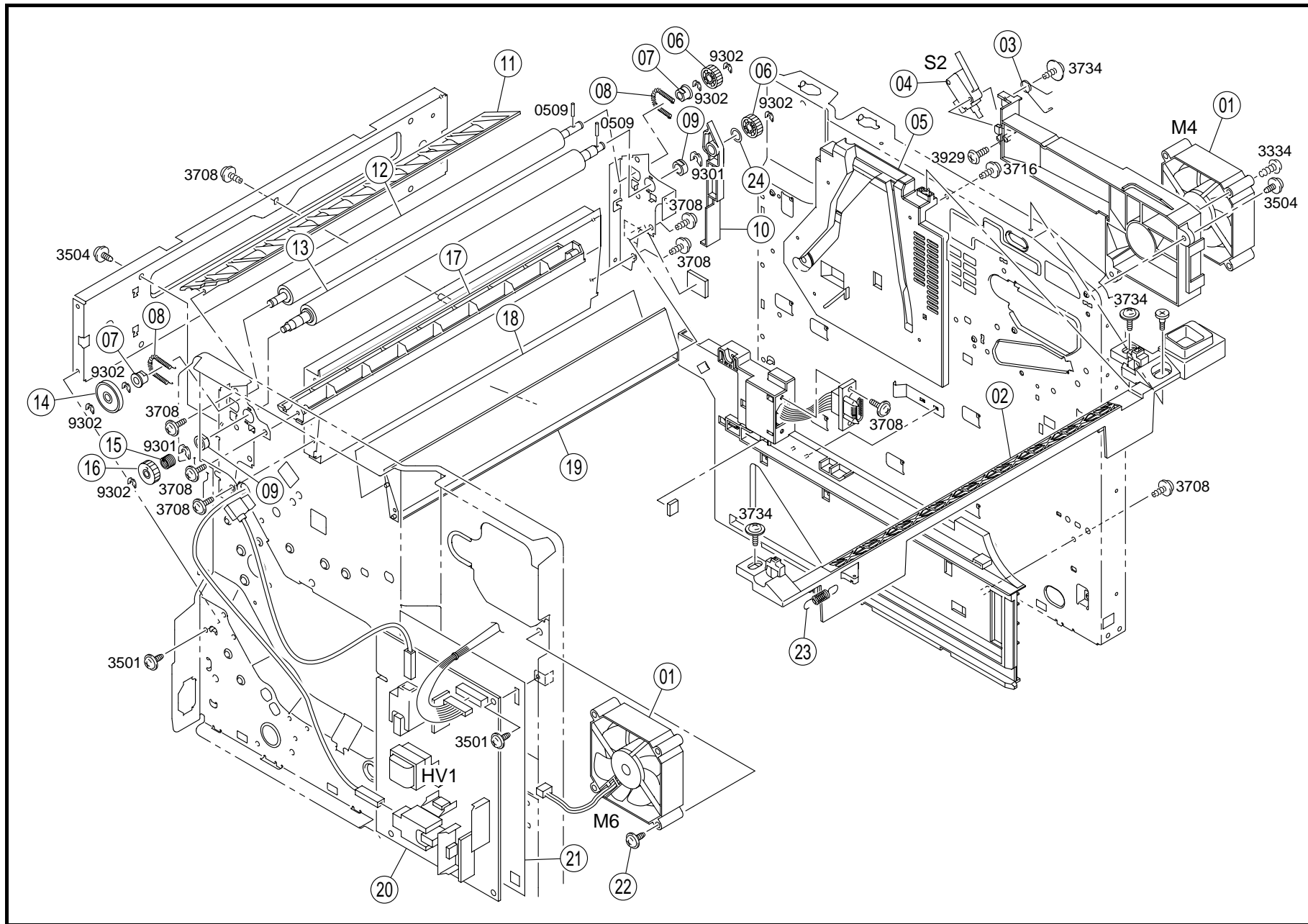

INDEX	PART NO.	PART NAME	REC	QTY	INDEX	PART NO.	PART NAME	REC	QTY
01	9313-1001-01	FAN MOTOR OZONE (M4.6)	RP	2	19	4128-3105-14	GUIDE		1
02	4128-2042-03	LEVER		1	20	4128-6203-02	HV TRANSFORMER HIGH-VOL. (HV1)	RP	1
03	4011-2037-01	TORSION SPRING		1	21	4128-2224-01	PROTECTION		1
04	9331-2710-11	MICRO SWITCH INTERLOCK (S2)	RP	1	22	0993-2045-01	SCREW		2
05	4128-0751-01	GUIDE ASSY		1	23	4128-2026-01	TENSION SPRING		1
06	4128-3143-01	GEAR		2	24	1200-1461-03	WASHER		1
07	4128-3110-01	BUSHING		2					
08	4658-3506-01	TENSION SPRING		2					
09	1200-3131-03	BUSHING		2					
10	4128-3114-02	LEVER		1					
11	4128-3171-01	GUIDE		1					
12	4128-3102-01	ROLLER		1					
13	4128-3101-01	ROLLER		1					
14	4128-3115-02	RING		1					
15	4128-3142-01	TORSION SPRING		1					
16	4128-3141-01	GEAR		1					
17	4128-3108-02	GUIDE		1					
18	4128-3116-03	GUIDE		1					
INDEX	PART NO.	PART NAME	REC	QTY	SFIX				

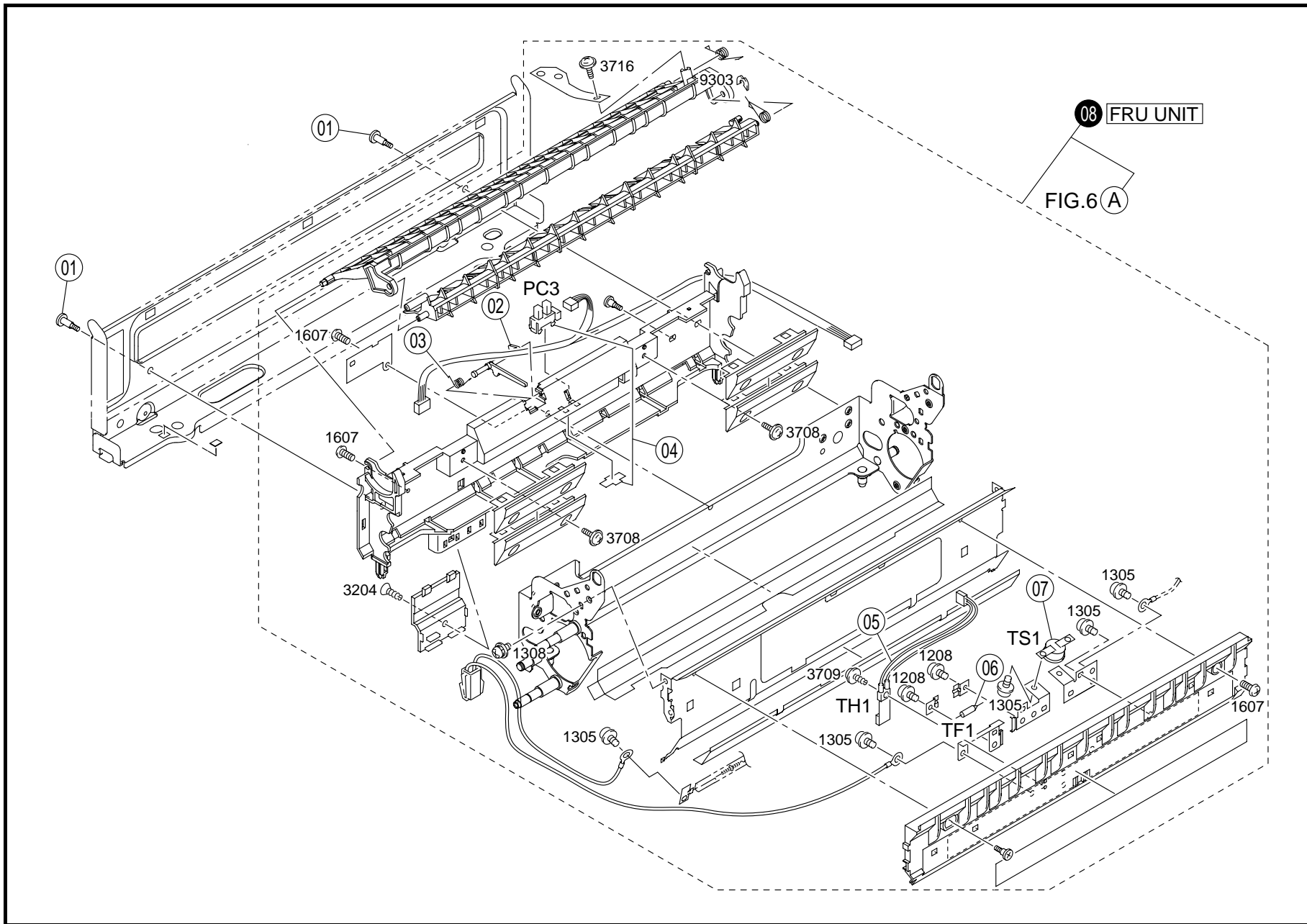

INDEX	PART NO.	PART NAME	REC	QTY	INDEX	PART NO.	PART NAME	REC	QTY
01	4128-5761-01	SHOULDER SCREW		2					
02	4128-5724-01	ACTUATOR		1					
03	0972-5519-01	TORSION SPRING		1					
04	4002-0902-01	PHOTO INTERRUPTER	P.OUTPUT (PC3) RP	1					
05	9372-2710-12	THERMISTOR	THERMISTOR (TH1) RP	1					
06	9346-3810-31	THERMAL FUSE	THERMAL (TF1) RP	1					
07	9334-1000-21	THERMAL SWITCH	THERMOSTAT (TS1) RP	1					
INDEX	PART NO.	PART NAME	REC	QTY	SFIX				
08	4570-111	FUSING UNIT	(FRU) RP	1	002				
08	4570-121	FUSING UNIT	(FRU) RP	1	302				
08	4570-131	FUSING UNIT	(FRU) RP	1	202				

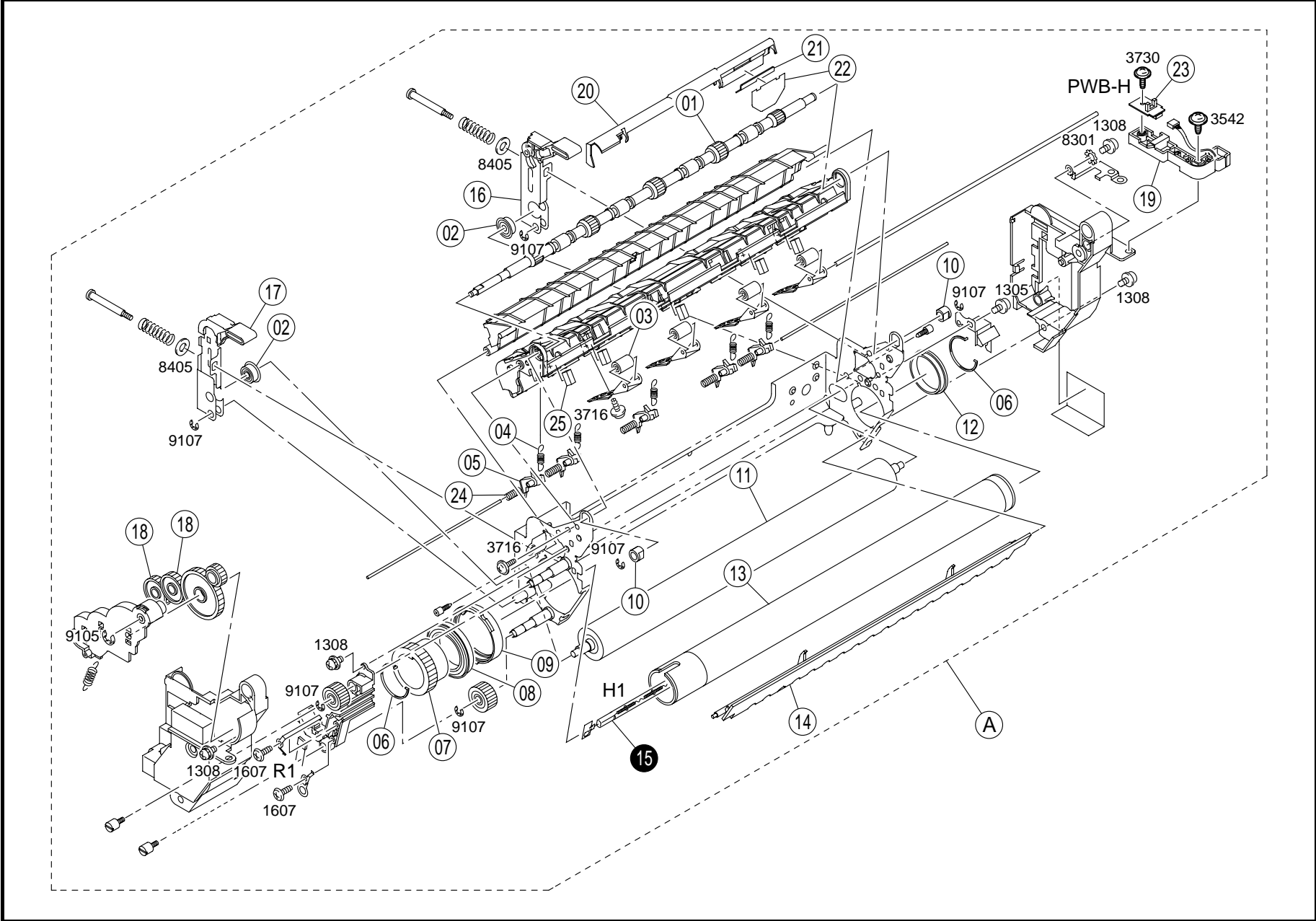

INDEX	PART NO.	PART NAME	REC	QTY	INDEX	PART NO.	PART NAME	REC	QTY
01	4128-5801-01	ROLLER		1	20	4128-5851-02	LEVER		1
02	4128-5708-01	BALL BEARING		2	21	4128-5852-01	WEIGHT		1
03	0993-3220-01	ROLL		4	22	4128-5853-01	GUIDE		1
04	4128-5757-01	TENSION SPRING		5	23	4128-0111-01	PWB ASSY	P.EXIT (PWB-H)	RP
05	4128-5728-02	SEPARATOR	RP	5	24	4128-5770-01	PRESSURE SPRING		5
06	1164-5772-01	STOP RING		2	25	4128-5771-01	CUSHION		5
07	1164-5709-01	GEAR	RP	1					
08	4128-5707-01	BALL BEARING	RP	1					
09	4128-5746-02	INSULATING MEMBER	RP	1					
10	4498-3406-01	BUSHING		2					
11	4128-5706-01	ROLLER	RP	1			FUSING/REAR		
12	4128-5709-02	BUSHING	RP	1					
13	4128-5705-01	ROLLER	RP	1			FUSING/FRONT		
14	4128-5760-03	SHIELD		1					
16	4128-0213-01	LEVER ASSY		1					
17	4128-0214-01	LEVER ASSY		1					
18	1164-5809-01	GEAR		2					
19	4128-5850-03	HOLDER		1					
INDEX	PART NO.	PART NAME	REC	QTY	SFIX				
15	9352-2001-54	HEATER	FUSING (H1)	RP	1	002			
15	9352-2001-62	HEATER	FUSING (H1)	RP	1	302			
15	9352-2001-72	HEATER	FUSING (H1)	RP	1	202			

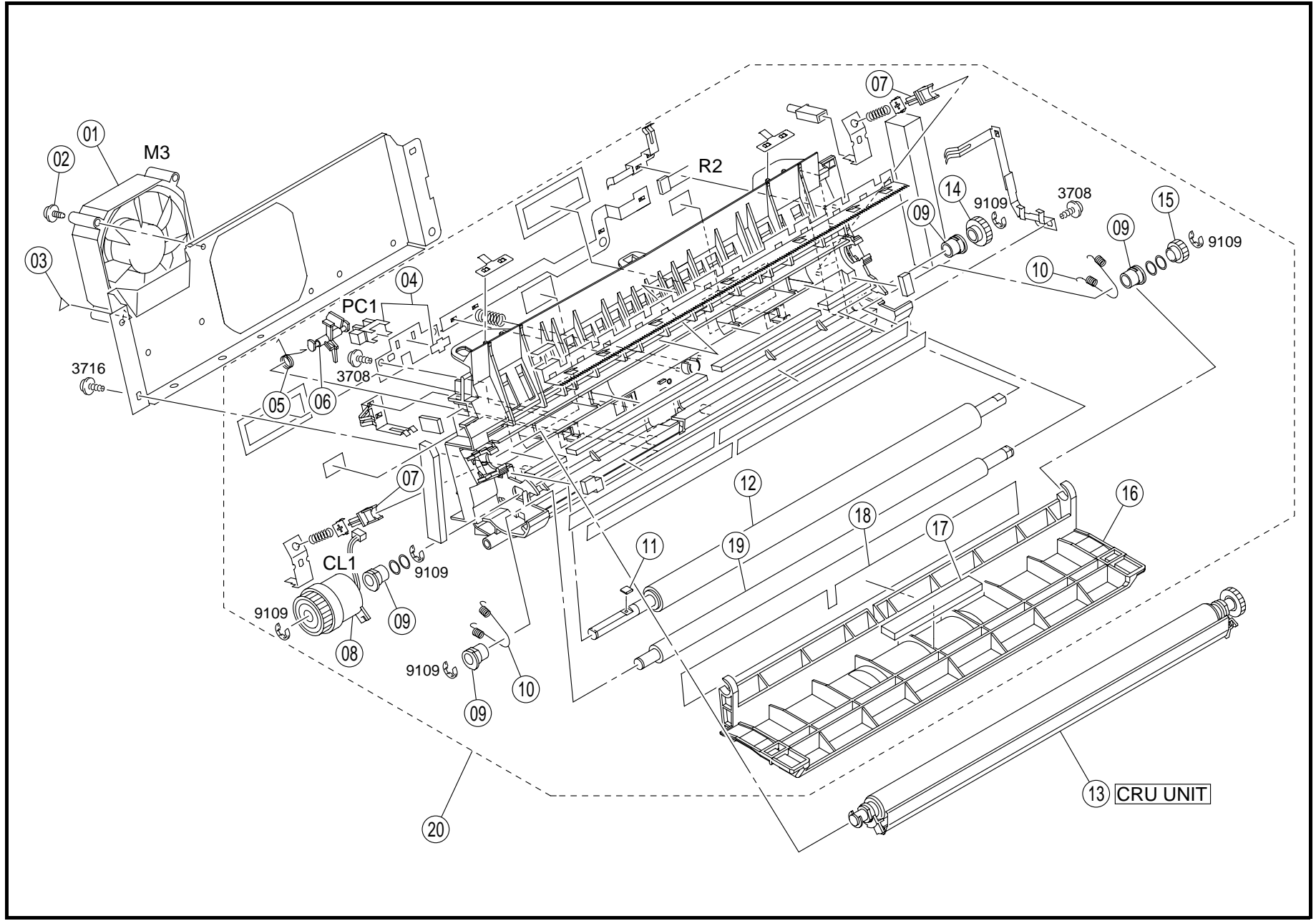

INDEX	PART NO.	PART NAME	REC	QTY	INDEX	PART NO.	PART NAME	REC	QTY
01	9313-1001-01	FAN MOTOR FUSING COOL (M3)	RP	1	19	4128-3507-01	ROLLER		1
02	0993-2045-01	SCREW		2	20	4128-0365-01	TRANSPORT UNIT	RP	1
03	0951-7105-03	LABEL		1					
04	4002-0902-01	PHOTO INTERRUPTER TRANSFER (PC1)	RP	1					
05	4128-3504-01	TORSION SPRING	RP	1					
06	4128-3503-01	ACTUATOR	RP	1					
07	1164-4206-02	BUSHING	RP	2					
08	9322-1000-31	CLUTCH TRANSPORT (CL1)	RP	1					
09	4128-3509-01	BUSHING		4					
10	4128-3513-01	TENSION SPRING		2					
11	1170-3534-01	HOLDER		1					
12	4128-3505-01	ROLLER		1					
13	1710503-001	TRANSFER UNIT (CRU)	RP	1					
14	1164-3508-01	GEAR		1					
15	4128-3515-01	GEAR		1					
16	4128-3502-02	GUIDE		1					
17	4128-3524-01	CUSHION		1					
18	4128-3519-01	GUIDE		1					

INDEX	PART NO.	PART NAME	REC	QTY	SFIX

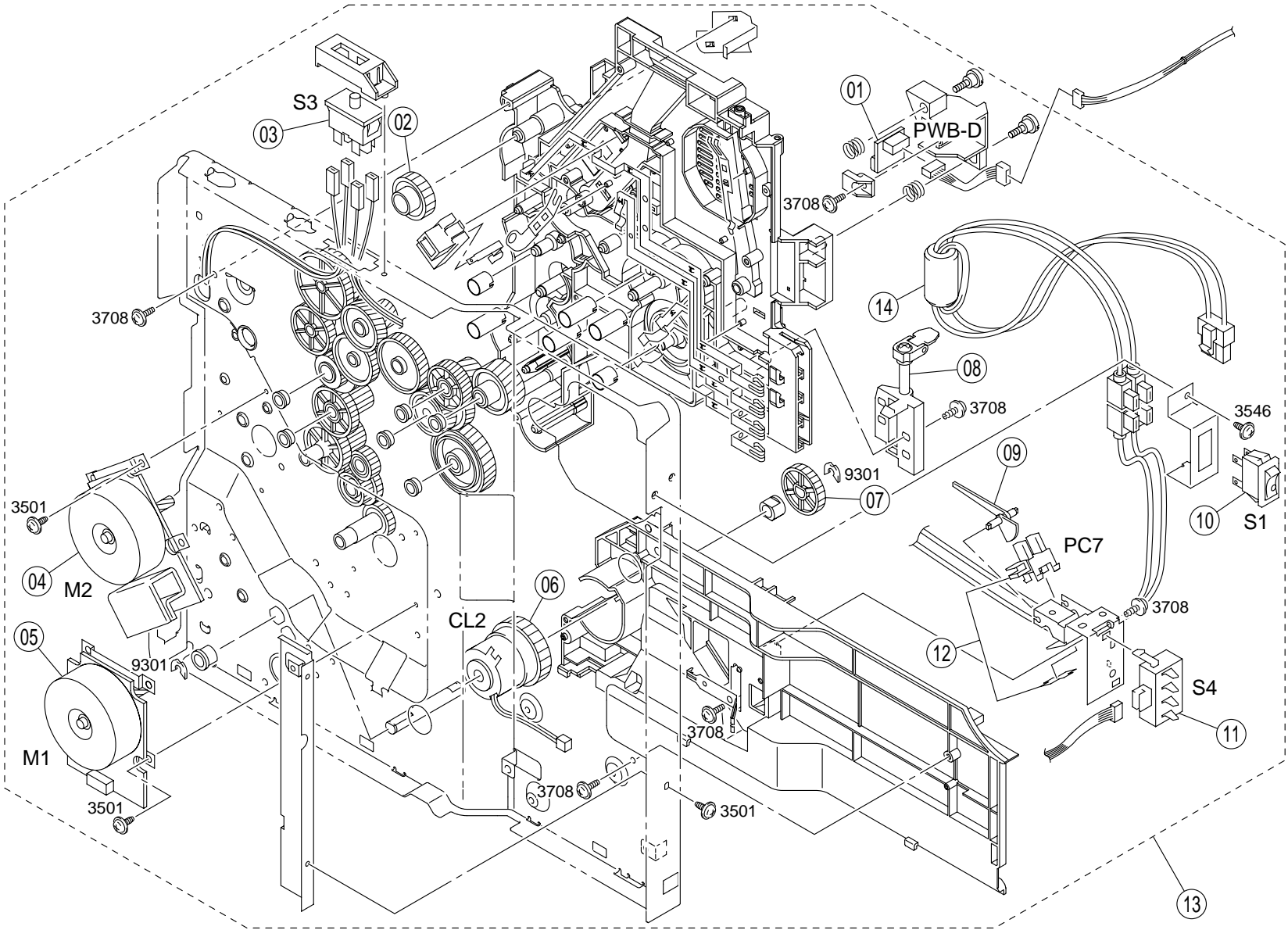

INDEX	PART NO.	PART NAME	REC	QTY	INDEX	PART NO.	PART NAME	REC	QTY
01	4128-0104-01	PWB ASSY DETECT (PWB-D)	RP	1					
02	4128-2518-01	GEAR		1					
03	9332-1710-41	SWITCH INTERLOCK (S3)	RP	1					
04	9314-2001-01	MOTOR IC DRIVE (M2)	RP	1					
05	9314-2000-91	MOTOR MAIN (M1)	RP	1					
06	9322-1000-21	CLUTCH P.TAKE-UP (CL2)	RP	1					
07	4128-3132-01	GEAR		1					
08	4128-0753-01	LOCK SHAFT ASSY	RP	1					
09	4128-3122-02	ACTUATOR	RP	1					
10	0990-6304-02	SWITCH MAIN POWER (S1)	RP	1					
11	9332-1000-11	PUSHBUTTON SWITCH P.DETECT (S4)	RP	1					
12	4002-0902-01	PHOTO INTERRUPTER NEAR EMPTY (PC7)	RP	1					
13	4128-0321-02	DRIVE UNIT	RP	1					
14	9326-1910-21	FERRITE CORE		1					

INDEX	PART NO.	PART NAME	REC	QTY	SFIX

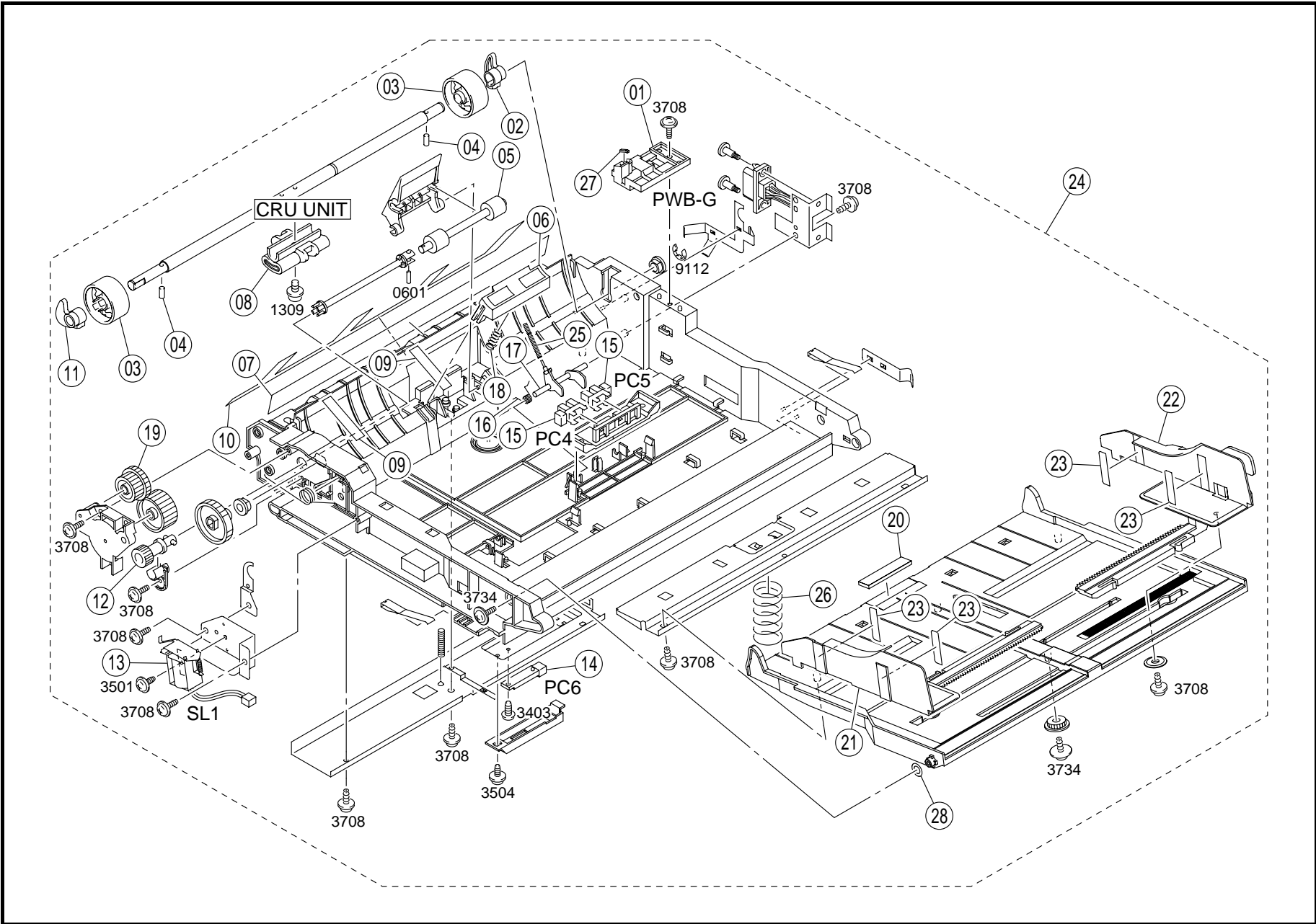

INDEX	PART NO.	PART NAME	REC	QTY	INDEX	PART NO.	PART NAME	REC	QTY
01	4128-0107-03	PWB ASSY T.EMPTY (PWB-G)	RP	1	19	4128-2512-01	GEAR		1
02	4128-3007-01	CAM		1	20	4128-3015-01	FRICTION SHEET		1
03	4122-3006-01	ROLL		2	21	4128-3048-03	REGULATING PLATE		1
04	0957-3040-01	PIN		2	22	4128-3047-03	REGULATING PLATE		1
05	4128-3002-01	ROLLER		1	23	4128-3034-13	BRAKE		4
06	4128-0754-01	SEPARATOR ASSY	RP	1	24	4128-0403-01	MULTIPLE TRAY ASSY	RP	1
07	4128-3030-01	GUIDE		1	25	4128-3050-01	TENSION SPRING		1
08	1710502-001	ROLLER ASSY TAKE-UP (CRU)	RP	1	26	4128-3016-02	PRESSURE SPRING		1
09	4128-3037-01	GUIDE		2	27	4128-2235-01	SHIELD PLATE		1
10	4128-3031-01	GUIDE		1	28	1200-1462-02	WASHER		1
11	4128-3008-01	CAM		1					
12	4128-3014-01	GEAR		1					
13	4122-6201-01	SOLENOID P.TAKE-UP (SL1)	RP	1					
14	9335-1910-51	SOLID STATE SWITCH FIRST P.EMPTY (PC6)	RP	1					
15	9335-1410-31	PHOTO INTERRUPTER P.EMPTY (PC4.5)	RP	2					
16	4128-3026-01	TORSION SPRING	RP	1					
17	4128-3027-02	ACTUATOR	RP	1					
18	4109-3041-03	PRESSURE SPRING		1					

INDEX	PART NO.	PART NAME	REC	QTY	SFIX

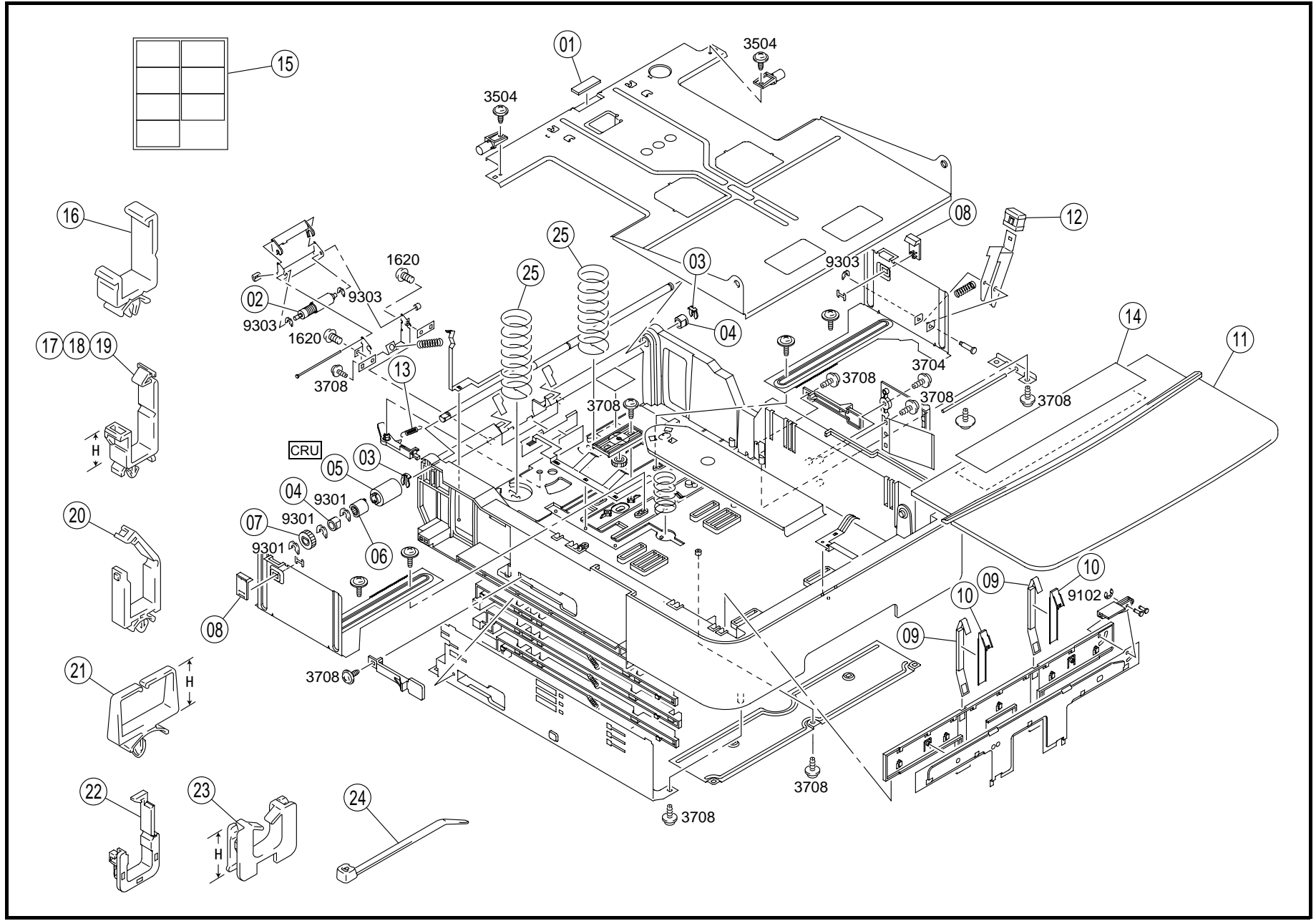

INDEX	PART NO.	PART NAME	REC	QTY	INDEX	PART NO.	PART NAME	REC	QTY
01	0978-3811-01	FRICITION SHEET		1	19	9384-1921-31	WIRING SADDLE 17.3H		1
02	4658-0151-01	ROLLER ASSY	SEPARATE	RP	1	20	9384-1310-11		1
03	4128-3215-01	STOP RING		2	21	9384-1310-81	WIRING SADDLE 6.4H		19
04	1274-3603-01	BUSHING		2	22	9384-2010-21	EDGE COVER 8.5H		5
05	1710528-001	ROLLER	TRANSFER (CRU)	RP	1	23	9384-2910-31		1
06	4658-3028-01	DRUM		1	24	9384-1311-11	CABLE TIE 104L		1
07	4128-3212-01	GEAR		1	25	4128-3243-01	PRESSURE SPRING		2
08	4658-3048-01	GUIDE		2					
09	4658-3016-01	MEMBER		2					
10	4128-3235-01	PLATE SPRING		2					
11	4128-3276-01	COVER		1					
12	4128-3279-01	KNOB		1					
13	4498-3404-01	TENSION SPRING		1					
14	4128-7321-01	LABEL		1					
15	4128-7323-01	LABEL		1					
16	9384-1310-91	WIRING SADDLE 18.5H		3					
17	9384-1921-11	WIRING SADDLE 9.2H		9					
18	9384-1921-21	WIRING SADDLE 15.2H		4					

INDEX	PART NO.	PART NAME	REC	QTY	SFIX

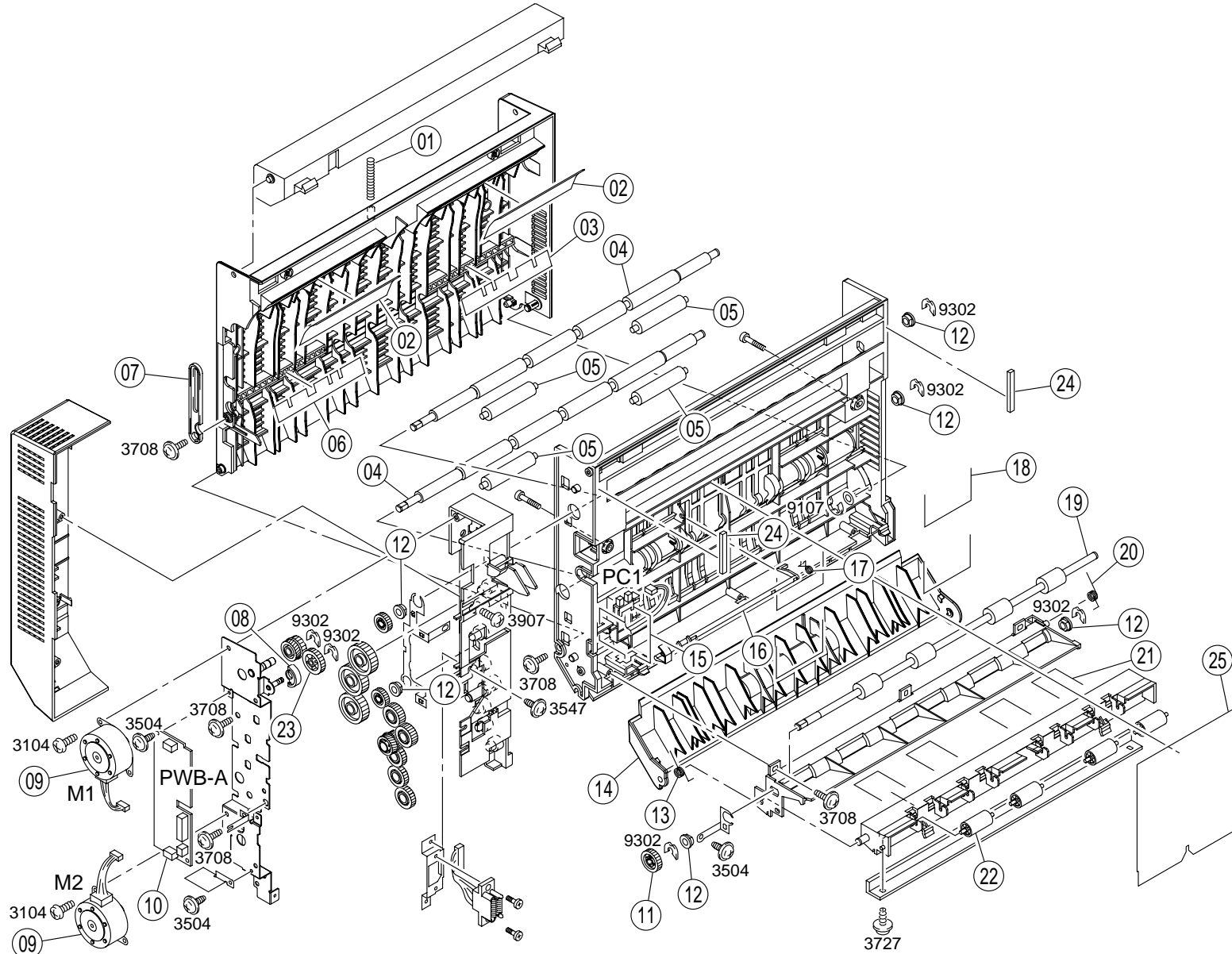

INDEX	PART NO.	PART NAME	REC	QTY	INDEX	PART NO.	PART NAME	REC	QTY
01	4497-3106-03	PRESSURE SPRING		1	19	4564-3803-02	ROLLER		1
02	4564-3823-01	GUIDE		2	20	4564-3824-01	TORSION SPRING		1
03	4497-3152-01	GUIDE		1	21	4603-3218-01	SPRING		4
04	4497-3113-02	ROLLER		2	22	4603-3207-01	ROLL		4
05	4497-3116-01	ROLL		4	23	4497-3122-01	GEAR		1
06	4497-3153-01	GUIDE		1	24	4564-3829-01	CUSHION		2
07	4497-3109-02	STOPPER		1	25	4564-3830-02	FILTER		1
08	4564-3815-01	RING		1					
09	9314-1000-91	MOTOR (M1.2)	RP	2					
10	4564-0101-02	PWB ASSY CONTROL (PWB-A)	RP	1					
11	4564-3807-01	GEAR		1					
12	1274-2611-01	BUSHING		6					
13	4564-3812-01	TORSION SPRING		1					
14	4564-3851-01	COVER		1					
15	4564-0901-01	PHOTO INTERRUPTER DOOR (PC1)	RP	1					
16	4497-3133-01	ACTUATOR	RP	1					
17	4497-3134-01	TORSION SPRING	RP	1					
18	4497-3114-01	MEMBER		4					

INDEX	PART NO.	PART NAME	REC	QTY	SFIX

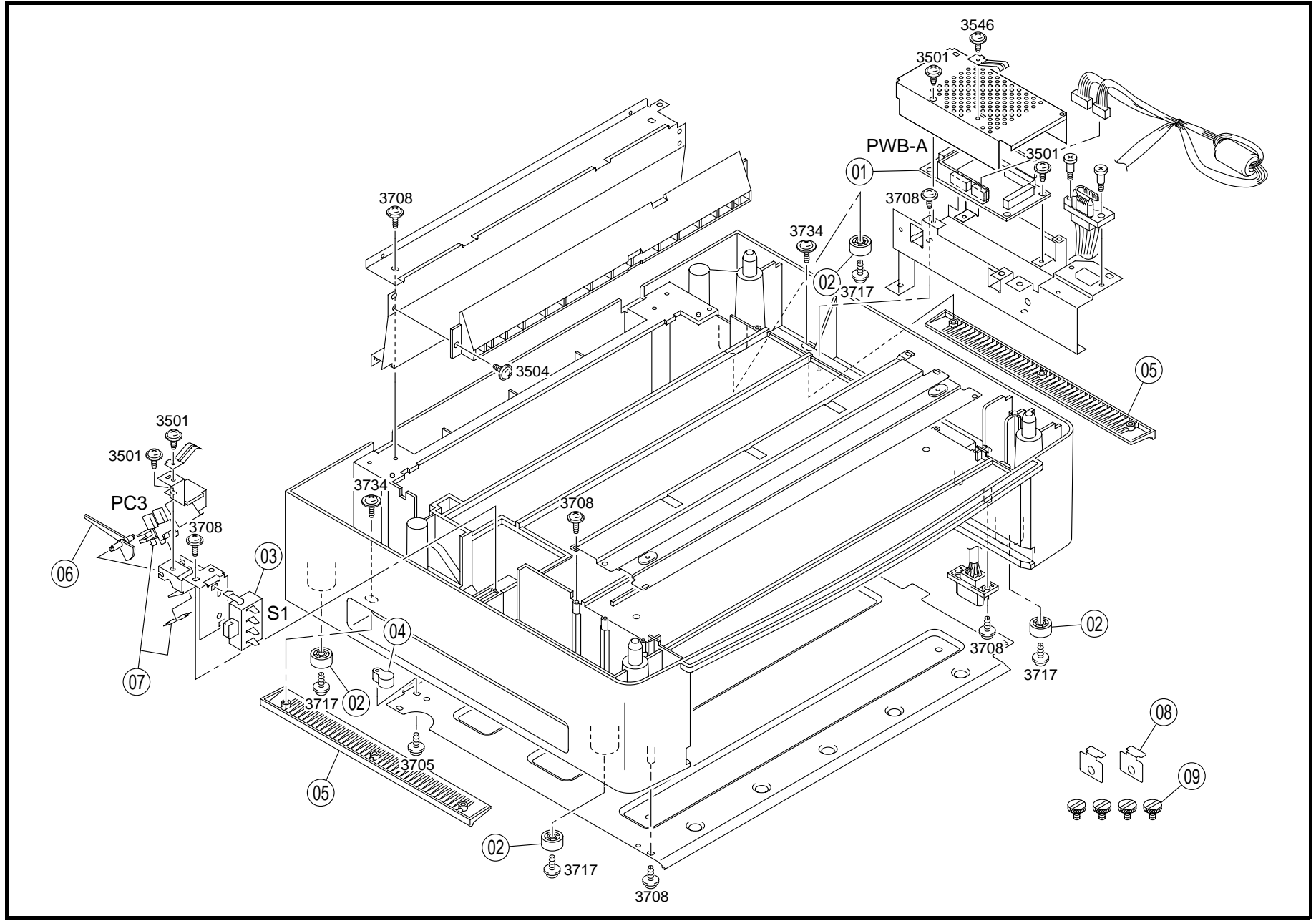

INDEX	PART NO.	PART NAME	REC	QTY	INDEX	PART NO.	PART NAME	REC	QTY
01	4565-0101-02	PWB ASSY CONTROL (PWB-A)	RP	1					
02	4498-3402-01	RUBBER FOOT		4					
03	9332-1000-11	PUSHBUTTON SWITCH P.SIZE DETECT (S1)	RP	1					
04	4128-2032-01	GUIDE		1					
05	4128-1225-01	HANDLE		2					
06	4128-3122-02	ACTUATOR	RP	1					
07	4002-0902-01	PHOTO INTERRUPTER P.NEAR EMPT (PC3)	RP	1					
08	4565-3303-01	COUPLING		2					
09	4565-3304-02	SCREW		4					
INDEX	PART NO.	PART NAME	REC	QTY	SFIX				

INDEX	PART NO.	PART NAME	REC	QTY	INDEX	PART NO.	PART NAME	REC	QTY
01	4658-3504-01	GEAR		2	19	4002-0902-01	PHOTO INTERRUPTER P.SENSOR (PC1)	RP	1
02	4128-3110-01	BUSHING		2					
03	4658-3506-01	TENSION SPRING		2					
04	4658-3514-01	ROLL		6					
05	4658-3513-01	ROLLER		3					
06	4565-3311-01	ROLLER		1					
07	1200-3131-03	BUSHING		2					
08	4565-3328-01	GEAR		1					
09	4128-3142-01	TORSION SPRING	RP	1					
10	4565-3325-01	GEAR	RP	1					
11	9314-1000-11	MOTOR P.TAKE-UP (M1)	RP	1					
12	1200-3131-07	BUSHING		2					
13	9322-1000-21	CLUTCH P.TAKE-UP (CL1)	RP	1					
14	4565-3324-01	GEAR		1					
15	4565-3326-01	GEAR		1					
16	4565-3317-01	TORSION SPRING	RP	1					
17	9335-1910-51	SOLID STATE SWITCH P.EMPTY (PC2)	RP	1					
18	4565-3316-01	ACTUATOR	RP	1					
INDEX	PART NO.	PART NAME	REC	QTY	SFIX				

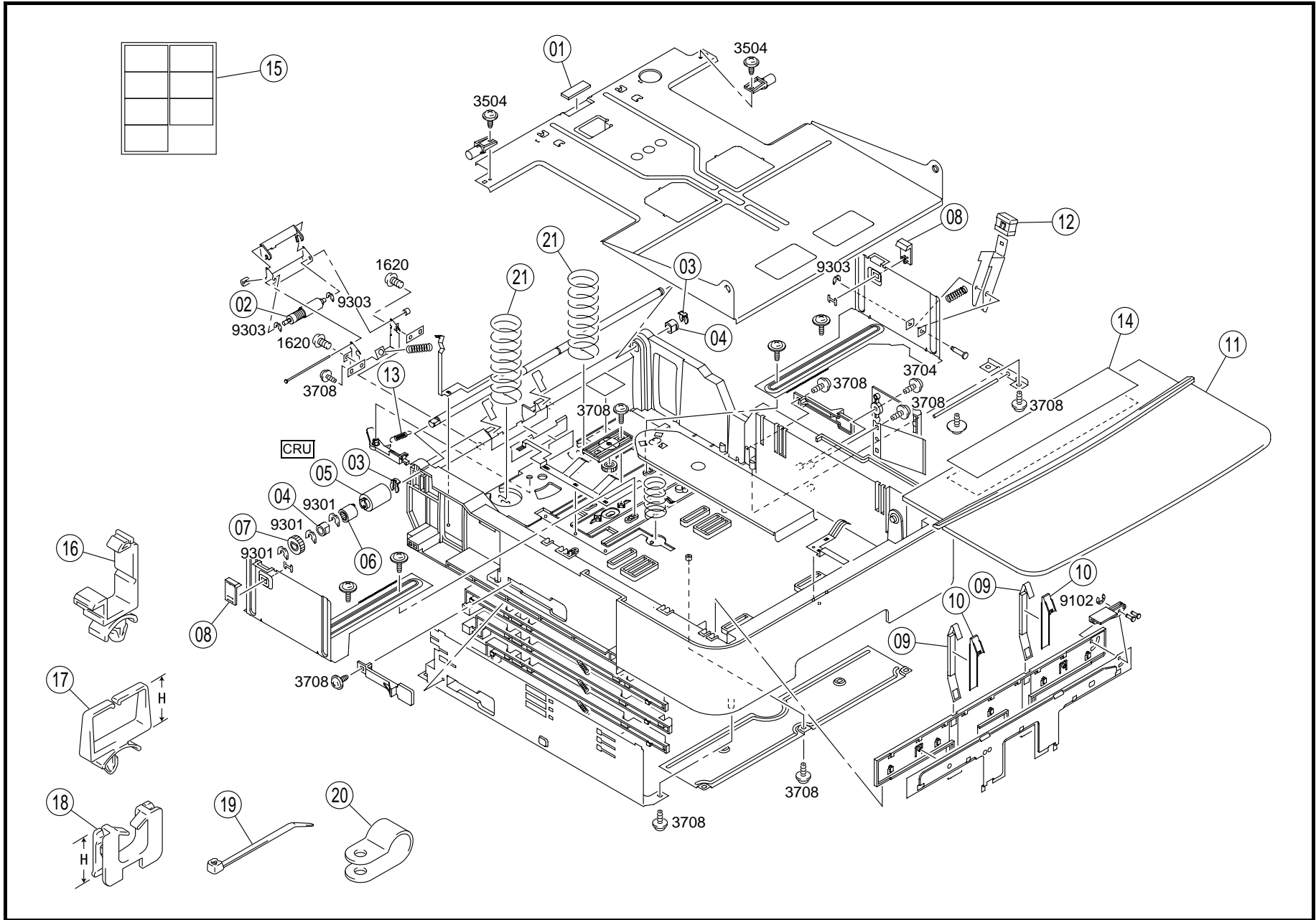

INDEX	PART NO.	PART NAME	REC	QTY	INDEX	PART NO.	PART NAME	REC	QTY
01	0978-3811-01	FRICITION SHEET		1	19	9384-1311-11	CABLE TIE 104L		1
02	4658-0151-01	ROLLER ASSY	RP	1	20	9384-1811-01	CORD CLAMP		1
03	4128-3215-01	STOP RING		2	21	4128-3243-01	PRESSURE SPRING		2
04	1274-3603-01	BUSHING		2					
05	1710528-001	ROLLER	RP	1					
06	4658-3028-01	DRUM		1					
07	4128-3212-01	GEAR		1					
08	4658-3048-01	GUIDE		2					
09	4658-3016-01	MEMBER		2					
10	4128-3235-01	PLATE SPRING		2					
11	4128-3276-01	COVER		1					
12	4128-3279-01	KNOB		1					
13	4498-3404-01	TENSION SPRING		1					
14	4128-7321-01	LABEL		1					
15	4128-7323-01	LABEL		1					
16	9384-1000-51	WIRING SADDLE		1					
17	9384-1310-81	WIRING SADDLE 6.4H		3					
18	9384-2010-21	EDGE COVER 8.5H		2					

INDEX	PART NO.	PART NAME	REC	QTY	SFIX

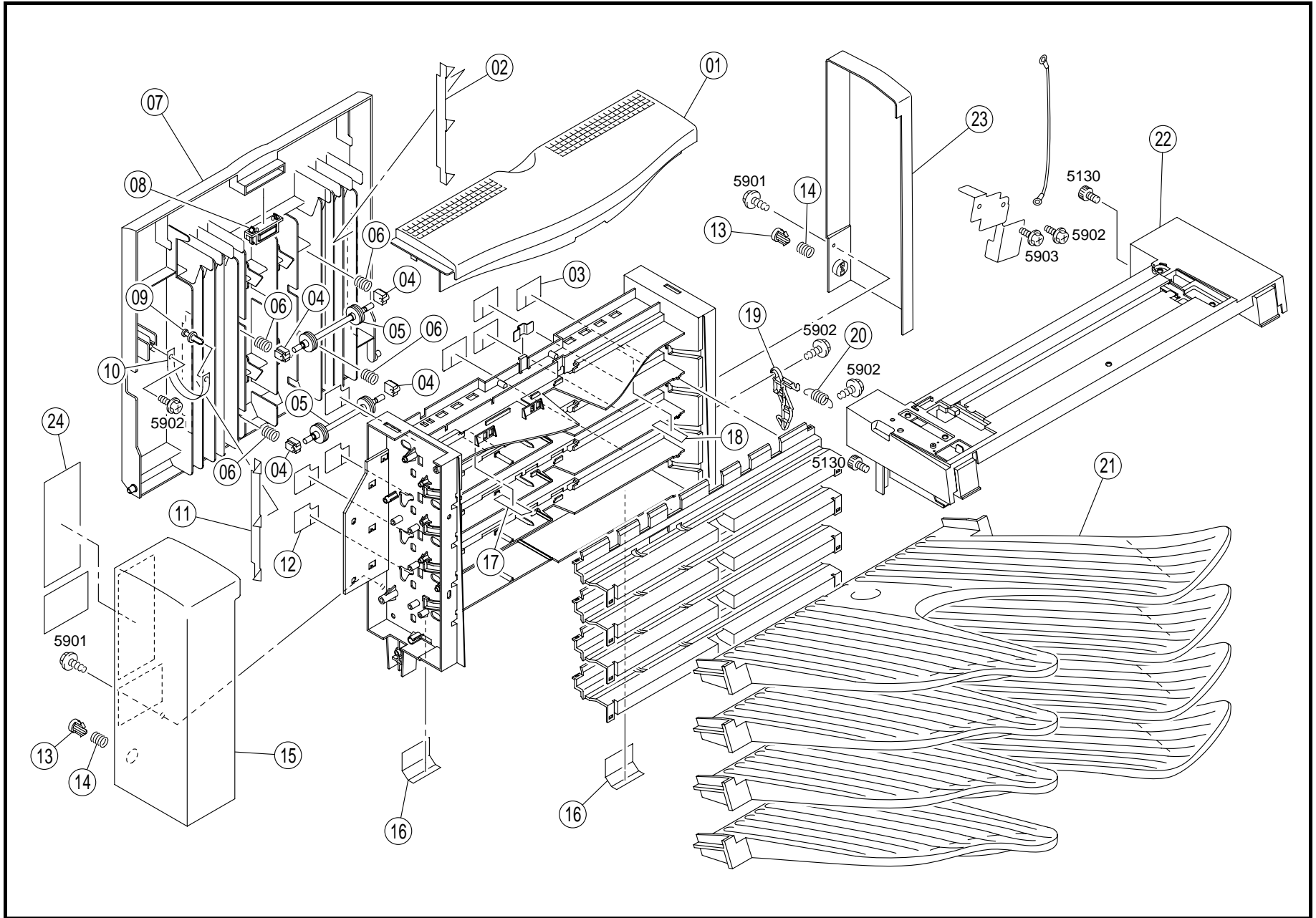

INDEX	PART NO.	PART NAME	REC	QTY	INDEX	PART NO.	PART NAME	REC	QTY
01	4566-5059-01	COVER		1	19	4566-5053-01	LEVER		1
02	4566-5025-01	GUIDE		1	20	4566-5052-01	TENSION SPRING		1
03	4566-5016-01	GUIDE		4	21	4566-5061-01	TRAY		4
04	4566-5045-01	BUSHING		4	22	4566-0161-03	GUIDE		1
05	4566-5011-01	ROLL		2	23	4566-5057-01	COVER		1
06	4566-5044-01	PRESSURE SPRING		4	24	4566-5062-01	LABEL		1
07	4566-5060-01	COVER		1					
08	4566-5036-01	MAGNET CATCH		1					
09	4566-5005-01	STOPPER		1					
10	4566-5037-01	BAND		1					
11	4566-5024-01	GUIDE		1					
12	4566-5015-01	GUIDE		4					
13	4566-5054-01	BUTTON		2					
14	4566-5055-01	PRESSURE SPRING		2					
15	4566-5058-01	COVER		1					
16	4566-5040-01	GUIDE		2					
17	4566-5017-01	SHEET		1					
18	4566-5018-01	SHEET		1					

INDEX	PART NO.	PART NAME	REC	QTY	SFIX

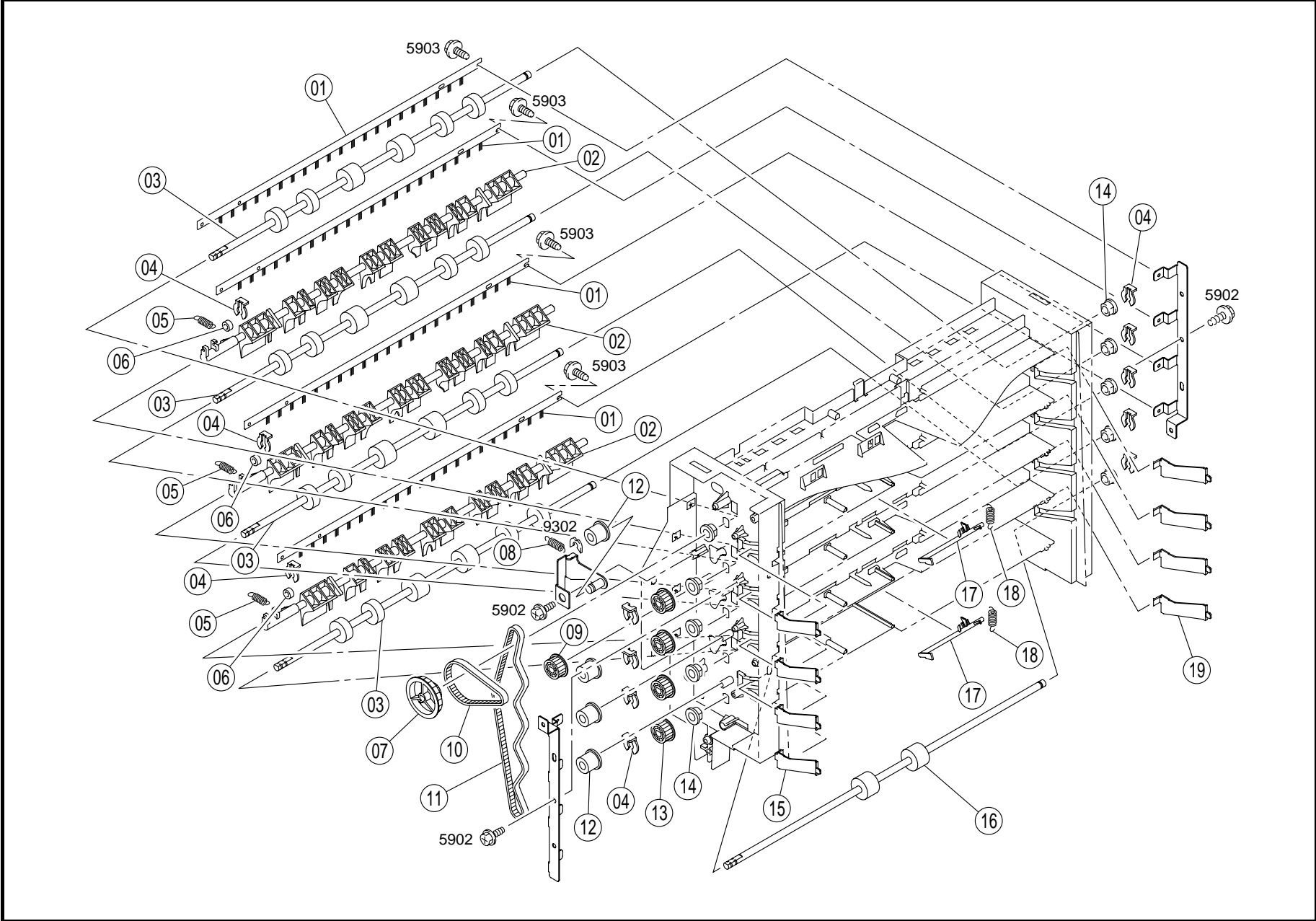





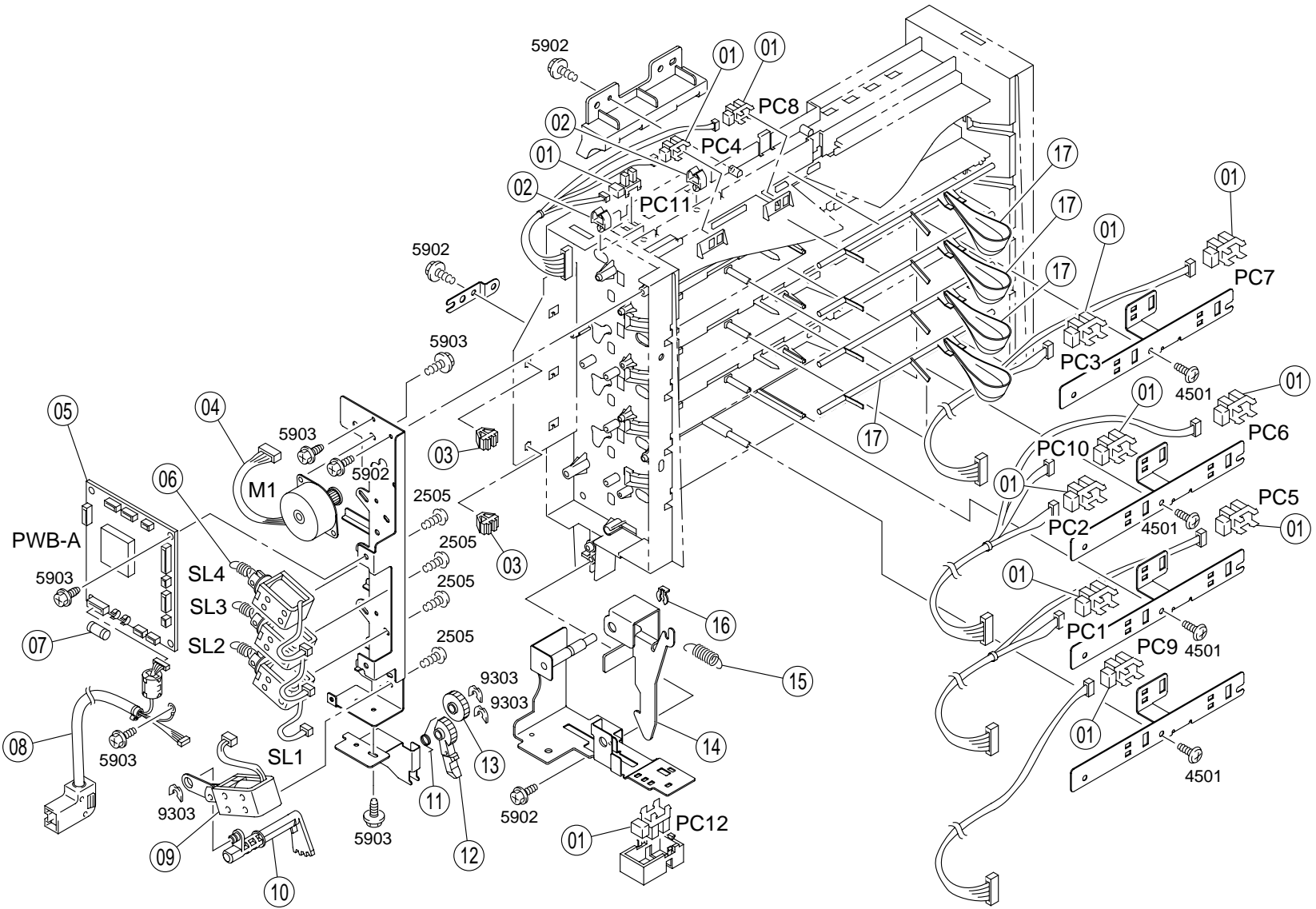











INDEX	PART NO.	PART NAME	REC	QTY	INDEX	PART NO.	PART NAME	REC	QTY
01	4566-5008-01	NEUTRALIZING BRUSH		4	19	4566-5038-01	COVER		4
02	4566-5046-01	GUIDE LEVER		3					
03	4566-5027-01	ROLLER		4					
04	1033-4402-01	STOPPER RING		12					
05	4566-5047-01	TENSION SPRING		3					
06	4566-5007-01	CUSHION		3					
07	4566-5010-01	PULLEY 57/28T		1					
08	4566-5050-01	TENSION SPRING		1					
09	4566-5009-01	PULLEY		1					
10	4566-5049-01	TIMING BELT		1					
11	4566-5051-01	TIMING BELT		1					
12	4566-5006-01	PULLEY		4					
13	4566-5056-01	PULLEY 28T		4					
14	4566-5001-01	BUSHING		10					
15	4566-5039-01	COVER		4					
16	4566-5026-01	ROLLER		1					
17	4566-5042-01	ACTUATOR		2					
18	4566-5043-01	TENSION SPRING		2					

INDEX	PART NO.	PART NAME	REC	QTY	SFIX



INDEX	PART NO.	PART NAME	REC	QTY	INDEX	PART NO.	PART NAME	REC	QTY
01	4566-5012-01	PHOTO INTERRUPTER (PC1-12)	RP	12					
02	4566-5003-01	WIRING SADDLE		2					
03	4566-5002-01	WIRING SADDLE		2					
04	4566-5013-01	MOTOR TRANSPORT (M1)	RP	1					
05	4566-5033-01	PWB-MAIN CONTROL (PWB-A)	RP	1					
06	4566-5014-01	SOLENOID ASSY BIN SW. (SL2-4)	RP	3					
07	4566-5004-01	FUSE	RP	1					
08	4566-5034-01	HARNES		1					
09	4566-5035-01	SOLENOID ASSY GUIDE SW. (SL1)	RP	1					
10	4566-5029-01	LEVER		1					
11	4566-5032-01	TORSION SPRING		1					
12	4566-5031-01	GEAR		1					
13	4566-5030-01	GEAR		1					
14	4566-5019-01	LOCK LEVER		1					
15	4566-5052-01	TENSION SPRING		1					
16	1033-4402-01	STOPPER RING		1					
17	4566-5041-01	ACTUATOR		4					

INDEX	PART NO.	PART NAME	REC	QTY	SFIX

INDEX	PART NO.	PART NAME	ILLUST	INDEX	PART NO.	PART NAME	ILLUST	INDEX	PART NO.	PART NAME	ILLUST		
0501	9752-3016-50	PIN		3501	9735-0306-13	TAPPING SCREW		8301	9712-0300-13	WASHER			
0509	9752-2012-50			3504	9735-0308-13			8405	9715-0500-01	WASHER			
0513	9752-2014-50			3524	9735-0316-13								
0601	9751-3010-50			3541	9735-0308-14								
1208	9644-0306-13	SCREW		3542	9735-0320-13								
				3546	4106-2063-01								
				3547	4154-3804-01								
1305	9646-0306-13	SCREW		3701	9739-0408-13	TAPPING SCREW		9102	9721-0200-01	RETAINING RING			
1308	9646-0308-13			3704	9739-0308-13			9105	9721-0300-01				
1309	9646-0310-13			3705	9739-0306-13			9107	9721-0400-01				
1318	9646-0408-13			3708	9739-0308-07			9109	9721-0500-01				
1607	9654-0306-13			3709	9739-0310-13			9112	9721-0600-01				
1620	9654-0406-01	SCREW		3716	9739-0306-07			9301	1066-1151-01	RETAINING RING			
2505	9642-0303-13			SCREW								3717	9739-0312-07
		3727	9739-0308-14									9302	4425-3001-01
2911	4128-1906-01	SCREW		3730	9739-0306-14							9303	4425-3002-01
				3734	1250-2301-01								
3104	9656-0308-13	TAPPING SCREW		3803	9762-2050-07								
				3906	9742-0306-13								
3204	9657-0308-13	TAPPING SCREW		3907	9742-0308-13								
				3929	9742-0314-13								
3334	9732-0434-13	TAPPING SCREW		4011	9743-0308-13								
				4021	9743-0308-14								
3403	9733-0308-13	TAPPING SCREW		4501	4566-5105-01								
				5130	9670-0410-13								
				5901	4566-5101-01								
				5902	4566-5102-01								
				5903	4566-5103-01								

PART NO.	FIG.	INDEX	QTY		PART NO.	FIG.	INDEX	QTY		PART NO.	FIG.	INDEX	QTY		PART NO.	FIG.	INDEX	QTY	
0951-7105-03	01	25	3		4128-1019-01	01	03	1		4128-3215-01	14	03	2		4564-3803-02	11	19	1	
0951-7105-03	03	15	1		4128-1020-02	01	09	1		4128-3235-01	10	10	2		4564-3807-01	11	11	1	
0951-7105-03	07	03	1		4128-1026-01	01	06	1		4128-3235-01	14	10	2		4564-3812-01	11	13	1	
0957-3040-01	09	04	2		4128-1031-03	01	13	1		4128-3243-01	10	25	2		4564-3815-01	11	08	1	
0972-5519-01	05	03	1		4128-1039-02	01	14	1		4128-3243-01	14	21	2		4564-3823-01	11	02	2	
0978-3811-01	10	01	1		4128-1221-01	01	05	1		4128-3276-01	10	11	1		4564-3824-01	11	20	1	
0978-3811-01	14	01	1		4128-1222-01	02	01	2		4128-3276-01	14	11	1		4564-3829-01	11	24	2	
0990-6304-02	08	10	1		4128-1225-01	01	10	2		4128-3279-01	10	12	1		4564-3830-02	11	25	1	
0993-2045-01	04	22	2		4128-1225-01	12	05	2		4128-3279-01	14	12	1		4564-3851-01	11	14	1	
0993-2045-01	07	02	2		4128-1227-01	01	16	2		4128-3502-02	07	16	1		4565-0101-02	12	01	1	
0993-3220-01	06	03	4		4128-1230-01	01	18	1		4128-3503-01	07	06	1		4565-3303-01	12	08	2	
1033-4402-01	16	04	12		4128-1978-01	02	16	2		4128-3504-01	07	05	1		4565-3304-02	12	09	4	
1033-4402-01	17	16	1		4128-1979-01	02	17	2		4128-3505-01	07	12	1		4565-3311-01	13	06	1	
1138-7811-01	02	18	2		4128-2019-01	02	05	5		4128-3507-01	07	19	1		4565-3316-01	13	18	1	
1164-3508-01	07	14	1		4128-2026-01	04	23	1		4128-3509-01	07	09	4		4565-3317-01	13	16	1	
1164-4206-02	07	07	2		4128-2031-01	02	13	1		4128-3513-01	07	10	2		4565-3324-01	13	14	1	
1164-5709-01	06	07	1		4128-2032-01	02	06	1		4128-3515-01	07	15	1		4565-3325-01	13	10	1	
1164-5772-01	06	06	2		4128-2032-01	12	04	1		4128-3519-01	07	18	1		4565-3326-01	13	15	1	
1164-5809-01	06	18	2		4128-2042-03	04	02	1		4128-3524-01	07	17	1		4565-3328-01	13	08	1	
1170-3534-01	07	11	1		4128-2043-01	03	06	1		4128-5705-01	06	13	1		4566-0161-03	15	22	1	
1200-1461-03	04	24	1		4128-2211-02	02	08	1		4128-5706-01	06	11	1		4566-5001-01	16	14	10	
1200-1462-02	09	28	1		4128-2212-01	02	12	1		4128-5707-01	06	08	1		4566-5002-01	17	03	2	
1200-3131-03	04	09	2		4128-2224-01	04	21	1		4128-5708-01	06	02	2		4566-5003-01	17	02	2	
1200-3131-03	13	07	2		4128-2235-01	09	27	1		4128-5709-02	06	12	1		4566-5004-01	17	07	1	
1200-3131-07	13	12	2		4128-2262-02	03	05	1		4128-5724-01	05	02	1		4566-5005-01	15	09	1	
1274-2611-01	11	12	6		4128-2263-01	03	03	2		4128-5728-02	06	05	5		4566-5006-01	16	12	4	
1274-3603-01	10	04	2		4128-2264-02	03	04	2		4128-5746-02	06	09	1		4566-5007-01	16	06	3	
1274-3603-01	14	04	2		4128-2269-01	03	11	1		4128-5757-01	06	04	5		4566-5008-01	16	01	4	
4002-0902-01	05	04	1		4128-2270-01	03	02	1		4128-5760-03	06	14	1		4566-5009-01	16	09	1	
4002-0902-01	07	04	1		4128-2272-01	03	01	1		4128-5761-01	05	01	2		4566-5010-01	16	07	1	
4002-0902-01	08	12	1		4128-2512-01	09	19	1		4128-5770-01	06	24	5		4566-5011-01	15	05	2	
4002-0902-01	12	07	1		4128-2518-01	08	02	1		4128-5771-01	06	25	5		4566-5012-01	17	01	12	
4002-0902-01	13	19	1		4128-3002-01	09	05	1		4128-5801-01	06	01	1		4566-5013-01	17	04	1	
4004-7402-01	01	26	1		4128-3007-01	09	02	1		4128-5814-01	01	02	1		4566-5014-01	17	06	3	
4011-2032-01	01	11	1		4128-3008-01	09	11	1		4128-5823-01	01	12	1		4566-5015-01	15	12	4	
4011-2037-01	04	03	1		4128-3014-01	09	12	1		4128-5850-03	06	19	1		4566-5016-01	15	03	4	
4109-3041-03	09	18	1		4128-3015-01	09	20	1		4128-5851-02	06	20	1		4566-5017-01	15	17	1	
4120-3255-02	03	14	1		4128-3016-02	09	26	1		4128-5852-01	06	21	1		4566-5018-01	15	18	1	
4120-7362-01	01	30	1		4128-3026-01	09	16	1		4128-5853-01	06	22	1		4566-5019-01	17	14	1	
4122-3006-01	09	03	2		4128-3027-02	09	17	1		4128-6054-02	03	17	1		4566-5024-01	15	11	1	
4122-6201-01	09	13	1		4128-3030-01	09	07	1		4128-6055-01	03	16	1		4566-5025-01	15	02	1	
4128-0104-01	08	01	1		4128-3031-01	09	10	1		4128-6056-02	03	17	1		4566-5026-01	16	16	1	
4128-0107-03	09	01	1		4128-3034-13	09	23	4		4128-6201-14	02	09	1		4566-5027-01	16	03	4	
4128-0108-05	01	31	1		4128-3037-01	09	09	2		4128-6202-14	02	09	1		4566-5029-01	17	10	1	
4128-0109-02	03	10	1		4128-3047-03	09	22	1		4128-6203-02	04	20	1		4566-5030-01	17	13	1	
4128-0110-03	01	31	1		4128-3048-03	09	21	1		4128-6807-01	02	03	1		4566-5031-01	17	12	1	
4128-0111-01	06	23	1		4128-3050-01	09	25	1		4128-7312-01	02	07	1		4566-5032-01	17	11	1	
4128-0112-01	03	10	1		4128-3051-01	03	07	1		4128-7320-01	01	29	1		4566-5033-01	17	05	1	
4128-0213-01	06	16	1		4128-3101-01	04	13	1		4128-7321-01	10	14	1		4566-5034-01	17	08	1	
4128-0214-01	06	17	1		4128-3102-01	04	12	1		4128-7321-01	14	14	1		4566-5035-01	17	09	1	
4128-0321-02	08	13	1		4128-3105-14	04	19	1		4128-7323-01	10	15	1		4566-5036-01	15	08	1	
4128-0365-01	07	20	1		4128-3108-02	04	17	1		4128-7323-01	14	15	1		4566-5037-01	15	10	1	
4128-0403-01	09	24	1		4128-3110-01	04	07	2		4128-7325-01	01	27	1		4566-5038-01	16	19	4	
4128-0532-02	02	14	1		4128-3110-01	13	02	2		4128-7326-01	01	28	1		4566-5039-01	16	15	4	
4128-0551-01	02	15	1		4128-3114-02	04	10	1		4497-3106-03	11	01	1		4566-5040-01	15	16	2	
4128-0751-01	04	05	1		4128-3115-02	04	14	1		4497-3109-02	11	07	1		4566-5041-01	17	17	4	
4128-0753-01	08	08	1		4128-3116-03	04	18	1		4497-3113-02	11	04	2		4566-5042-01	16	17	2	
4128-0754-01	09	06	1		4128-3122-02	08	09	1		4497-3114-01	11	18	4		4566-5043-01	16	18	2	
4128-1002-01	01	19	1		4128-3122-02	12	06	1		4497-3116-01	11	05	4		4566-5044-01	15	06	4	
4128-1003-03	01	01	1		4128-3132-01	08	07	1		4497-3122-01	11	23	1		4566-5045-01	15	04	4	
4128-1004-01	01	08	1		4128-3141-01	04	16	1		4497-3133-01	11	16	1		4566-5046-01	16	02	3	
4128-1005-01	01	20	1		4128-3142-01	04	15	1		4497-3134-01	11	17	1		4566-5047-01	16	05	3	
4128-1006-01	01	21	1		4128-3142-01	13	09	1		4497-3152-01	11	03	1		4566-5049-01	16	10	1	
4128-1007-01	01	24	1		4128-3143-01	04	06	2		4497-3153-01	11	06	1		4566-5050-01	16	08	1	
4128-1008-02	01	07	1		4128-3171-01	04	11	1		4498-3402-01	12	02	4		4566-5051-01	16	11	1	
4128-1010-01	01	04	1		4128-3212-01	10	07	1		4498-3404-01	10	13	1		4566-5052-01	15	20	1	
4128-1012-01	01	22	1		4128-3212-01	14	07	1		4498-3404-01	14	13	1		4566-5052-01	17	15	1	
4128-1013-04	01	17	1		1710528-001	10	05	1		4498-3406-01	06	10	2		4566-5053-01	15	19	1	
4128-1014-02	01	23	1		1710528-001	14	05	1		4564-0101-02	11	10	1		4566-5054-01	15	13	2	
4128-1015-01	01	15	1		4128-3215-01	10	03	2		4564-0901-01	11	15	1		4566-5055-01	15	14	2	

A
B
C
D
E
F
G
H
I
J
K
L

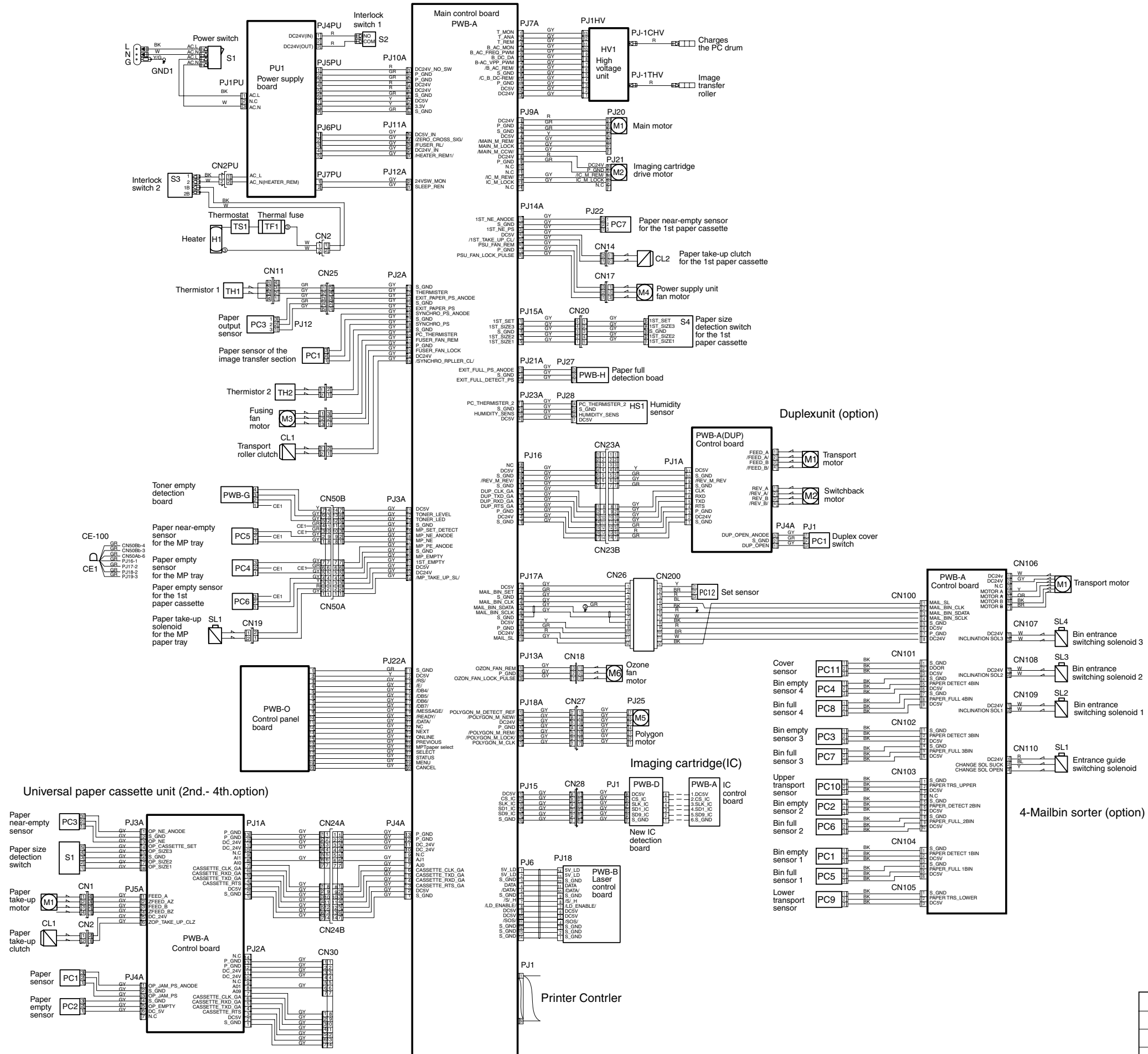

DWG.No.	4128-A001-01A
Title	WIRING DIAGRAM
MODEL	PagePro 9100
VOLTAGE	AC120V/ 230V
DATE ISSUED	Sep. 2001

